

TRANSPORTER ELECTRICAL BLACK LINE CLEAN LINE



TRANSPORTER ELECTRICAL



2299.60.1□100.
Transporter BLACK LINE

2299.60.1□100.□□
Control unit BLACK LINE



DESCRIPTION:

The electrically driven and patented transporter has been constructed to provide effective and affordable solutions to problems in parts transport, waste disposal as well as parts sorting. This system conveys punched and waste parts out of the tooling area with a rhythmic movement in a straight line.

A specially designed guide channel which is screwed to the body of the conveyor vibrates rhythmically slowly forwards and fast backwards. The mass inertia of the parts is used to move them forwards. In this way the parts in the guide channel progress gently towards the storage containers.

Low energy consumption, infinitely variable speed control, simple automation, low noise (60 dB) and the absence of compressed air ensure high economic efficiency whilst improving the working environment.

Its main areas of application are conveying and separating solid materials in metal processing and the automotive sector. The additional "CLEAN LINE" product range can also be used in the food and pharmaceutical industries.

The electric transporter is always operated with the corresponding 2299.6X. control unit. Integration with the PLC on the power press or production machine allows the programming of the transport time or shutdown of the press in the event of faults.



SIMPLE AUTOMATION:



Infeed



Separation



Organising



Positioning



Storage



Picking

TRANSPORTER ELECTRICAL

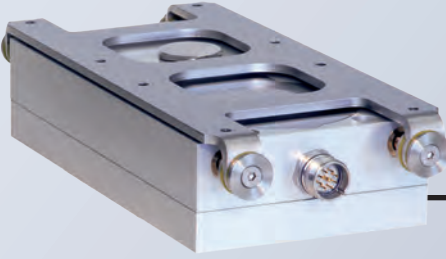

2299.61.1□100.
Transporter CLEAN LINE

2299.61.1□100.12
Control unit CLEAN LINE



MOUNTING EXAMPLES:

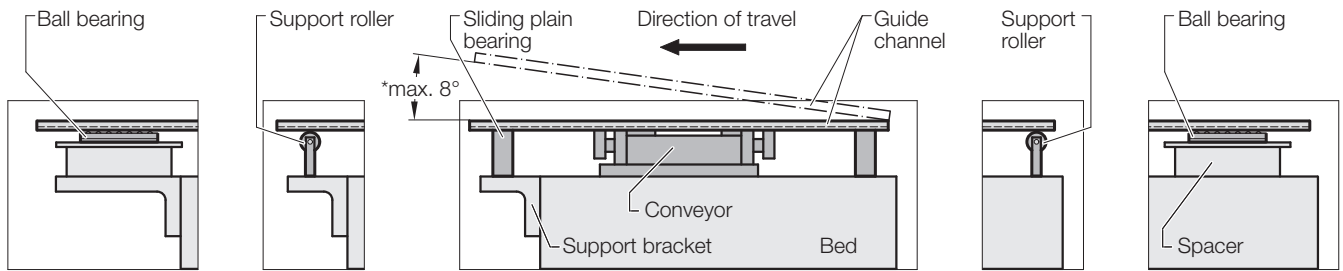
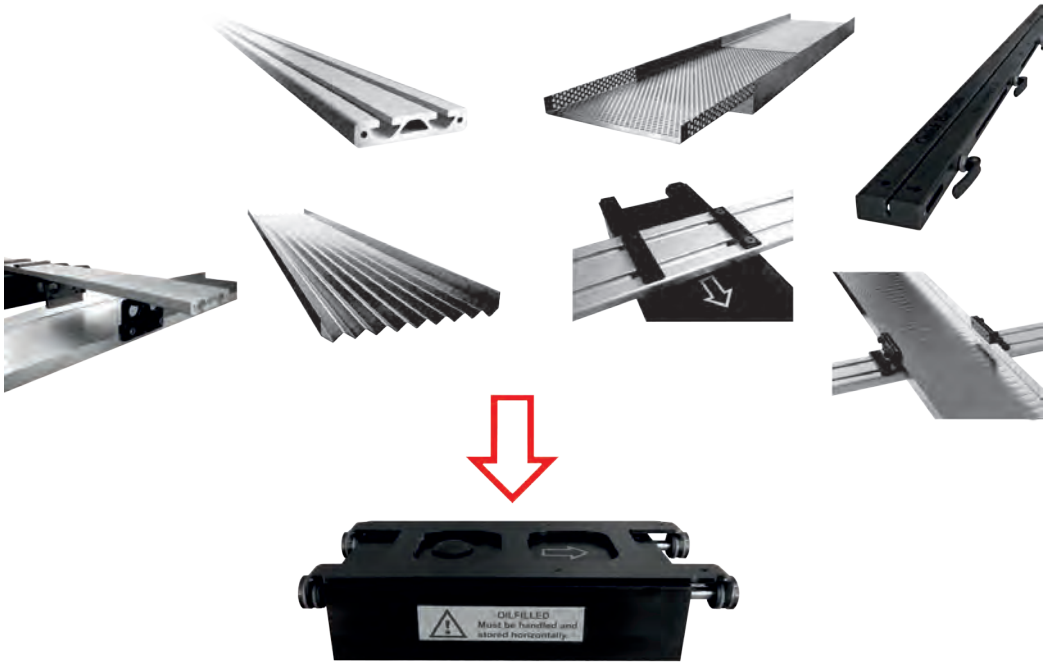

We recommend three options for supporting a long guide channel: 1) Ball bearings 2) Roller supports 3) Sliding plain bearings

*A chute incline can reduce the conveyor speed by up to 50%.

TRANSPORTER ELECTRICAL BLACK LINE, MINI

2299.60.18100.

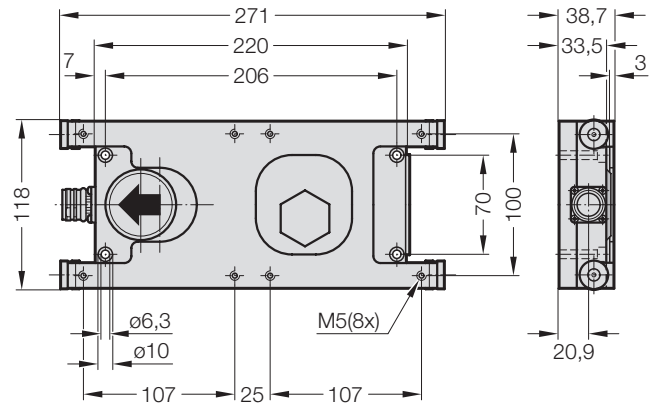

Description:

The electric transporter simplifies automation, increases energy efficiency and reduces noise pollution. The speed can be adjusted mechanically and, depending on the task type, the transporter conveys, sorts or separates electrically.

Used predominantly in metal processing and the automotive industry.

Material:

High-strength steel and anodised aluminium

Order example:

Order numbers for electric transporter
BLACK LINE, MINI

without connection cable (2299.60.82.0x.xx)

2299.60.18100.**00** without Control unit, 230 V

2299.60.18100.**01** with Control unit, 230 V

Max. transport weight (excl. channel)	10 kg
Max. channel weight	4 kg
Stroke length	20 mm
Conveying speed (mechanically adjustable)	4 - 8 m/min.
Warning system (motion sensor)	integrated
Start/stop	Controllable via PLC
Motor and overload protection	integrated
Noise emissions	60 dB (A)
Power consumption	0.05 kW
Electrical connection, control unit	M23
Protection type	IP62
Dimensions (LxBxH)	271 mm x 118 mm x 38 mm
Weight	2.65 kg
Temperature operating range (environment temperature)	-20 up to +100 °C

The connection cable, control unit transporter and optionally the signal cable, control unit press are to be ordered separately. For more information on the electrical connection, control unit and guide channel, see Accessories.

Socket head screws DIN EN ISO 4762 M6x40 (x 4) for fastening the transporter are included in delivery.

TRANSPORTER ELECTRICAL BLACK LINE, COMPACT

2299.60.14100.

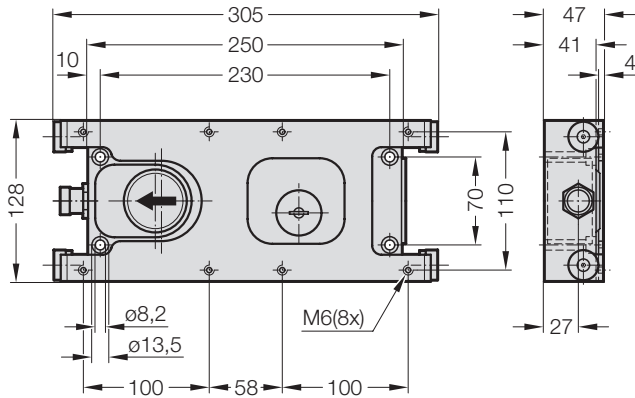

Description:

The electric transporter simplifies automation, increases energy efficiency and reduces noise pollution. The speed can be adjusted mechanically and, depending on the task type, the transporter conveys, sorts or separates electrically.

Used predominantly in metal processing and the automotive industry.

Material:

High-strength steel and anodised aluminium

Order example:

Order numbers for electric transporter

BLACK LINE, COMPACT

without connection cable (2299.60.82.0x.xx)

2299.60.14100.00 **without** Control unit, 230 V

2299.60.14100.01 **with** Control unit, 230 V

Max. transport weight (excl. channel)	20 kg
Max. channel weight	8 kg
Stroke length	20 mm
Conveying speed (mechanically adjustable)	4 - 8 m/min.
Warning system (motion sensor)	integrated
Start/stop	Controllable via PLC
Motor and overload protection	integrated
Noise emissions	60 dB (A)
Power consumption	0.07 kW
Electrical connection, control unit	M23
Protection type	IP62
Dimensions (LxBxH)	305 mm x 128 mm x 47 mm
Weight	3.7 kg
Temperature operating range (environment temperature)	-20 up to +100 °C

The connection cable, control unit transporter and optionally the signal cable, control unit press are to be ordered separately.

For more information on the electrical connection, control unit and guide channel, see Accessories.

Socket head screws DIN EN ISO 4762 M8x50 (x 4) for fastening the transporter are included in delivery.

TRANSPORTER ELECTRICAL BLACK LINE, MAX

2299.60.12100.

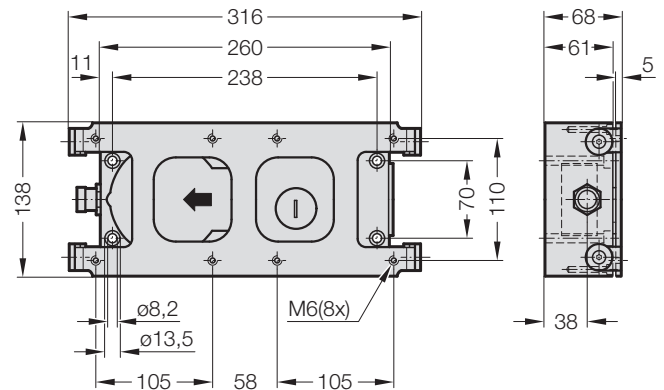

Description:

The electric transporter simplifies automation, increases energy efficiency and reduces noise pollution. The speed can be adjusted mechanically and, depending on the task type, the transporter conveys, sorts or separates electrically.

Used predominantly in metal processing and the automotive industry.

Material:

High-strength steel and anodised aluminium

Order example:

Order numbers for electric transporter,
BLACK LINE, MAX

without connection cable (2299.60.82.0x.xx)

2299.60.12100.**00** without Control unit, 230 V

2299.60.12100.**01** with Control unit, 230 V

Max. transport weight (excl. channel)	40 kg
Max. channel weight	16 kg
Stroke length	20 mm
Conveying speed (mechanically adjustable)	4 - 8 m/min.
Warning system (motion sensor)	integrated
Start/stop	Controllable via PLC
Motor and overload protection	integrated
Noise emissions	60 dB (A)
Power consumption	0.15 kW
Electrical connection, control unit	M23
Protection type	IP62
Dimensions (LxBxH)	316 mm x 138 mm x 68 mm
Weight	6.3 kg
Temperature operating range (environment temperature)	-20 up to +100 °C

The connection cable, control unit transporter and optionally the signal cable, control unit press are to be ordered separately. For more information on the electrical connection, control unit and guide channel, see Accessories.

Socket head screws DIN EN ISO 4762 M8x70 (x 4) for fastening the transporter are included in delivery.

TRANSPORTER ELECTRICAL BLACK LINE, ULTRA

2299.60.10100.

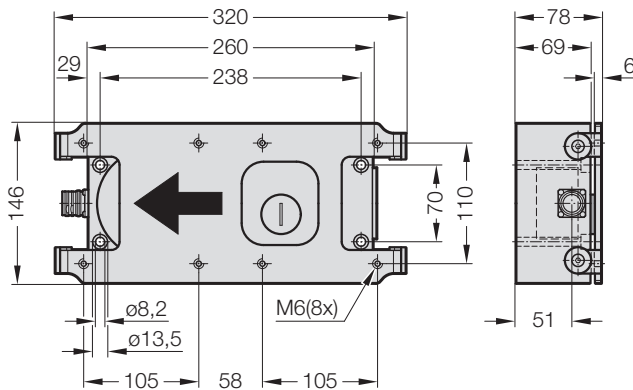

Description:

The electric transporter simplifies automation, increases energy efficiency and reduces noise pollution. The speed can be adjusted mechanically and, depending on the task type, the transporter conveys, sorts or separates electrically.

Used predominantly in metal processing and the automotive industry.

Material:

High-strength steel and anodised aluminium

Order example:

Order numbers for electric transporter BLACK LINE, ULTRA

without connection cable (2299.60.82.0x.xx)

2299.60.10100.**00** without Control unit, 230 V

2299.60.10100.**02*** with Control unit, 230 V

*potential free output

Max. transport weight (excl. channel)	100 kg
Max. channel weight	50 kg
Stroke length	20 mm
Conveying speed (mechanically adjustable)	4 - 8 m/min.
Warning system (motion sensor)	integrated
Start/stop	Controllable via PLC
Motor and overload protection	integrated
Noise emissions	60 dB (A)
Power consumption	0.25 kW
Electrical connection, control unit	M23
Protection type	IP62
Dimensions (LxBxH)	320 mm x 146 mm x 78 mm
Weight	9 kg
Temperature operating range (environment temperature)	-20 up to +100 °C

The connection cable, control unit transporter and optionally the signal cable, control unit press are to be ordered separately. For more information on the electrical connection, control unit and guide channel, see Accessories.

Socket head screws DIN EN ISO 4762 M8x80 (x 4) for fastening the transporter are included in delivery.

TRANSPORTER ELECTRICAL – ACCESSORIES

CONTROL UNIT BLACK LINE, SIGNAL CABLE, CONNECTION CABLE

2299.60.1□100.12/13 –
CONTROL UNIT BLACK LINE

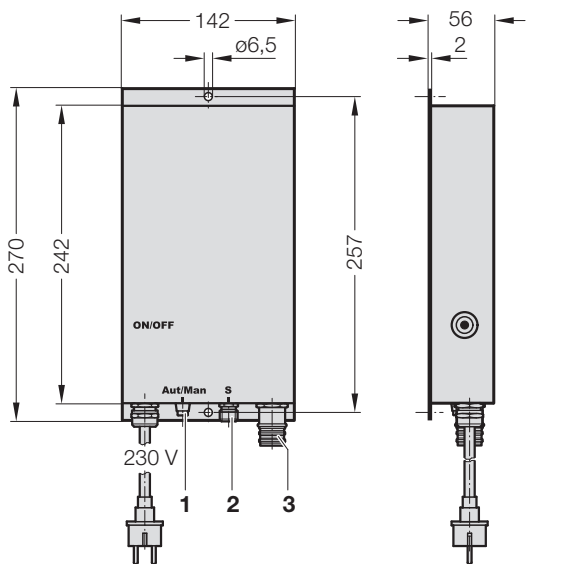

Order No	Connection	Power requirement
2299.60.10100.13*	230 V	1,8 - 3,5 A
2299.60.12100.12	230 V	1,2 - 2,2 A
2299.60.14100.12	230 V	0,75 - 1,7 A
2299.60.18100.12	230 V	0,55 - 1,3 A

1-phase 110-230 V, 50-60 Hz, earthed connection

*potential free output

Description:

The control unit is the electrical module for controlling the transporter.

Note:

The control unit must be mounted on a metal surface for heat dissipation. Before connecting the electric transporter, check that the channel can move freely in the direction of travel.

Included in the delivery,

Mains connection incl. plugs for USA and GB

Fixing bolts ISO 7380-1 M6 x 8 (x2)

Material:

Steel

IP54

Technical specifications:

Temperature operating range: -20 to +40 °Celsius
(environment temperature)

1 - Changeover between PLC and manual operation



PLC mode:

In this position, this start/stop function is controlled via the straight signal cable (M12 plug).



Manual mode:

In this position, the start/stop function is controlled by the control unit.

2 - 2299.60.81.01. Signal cable straight, to the press

order separately

Order No	l [m]
2299.60.81.01.03	3
2299.60.81.01.05	5
2299.60.81.01.10	10

For further information, see catalogue page for straight signal cable

3 - 2299.60.82.01. Connection cable straight/straight, control unit - transporter

order separately

Order No	l [m]
2299.60.82.01.03	3
2299.60.82.01.05	5
2299.60.82.01.10	10
2299.60.82.01.15	15

2299.60.82.02. Connection cable straight/90°, control unit - transporter

order separately

Order No	l [m]
2299.60.82.02.03	3
2299.60.82.02.05	5
2299.60.82.02.10	10
2299.60.82.02.15	15

TRANSPORTER ELECTRICAL CLEAN LINE, MINI

2299.61.18100.

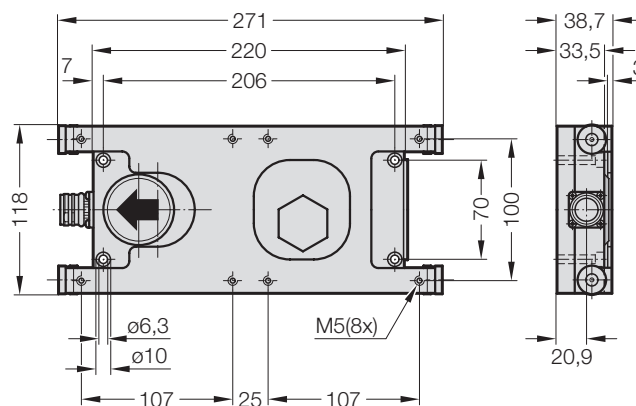

Description:

The electric transporter simplifies automation, increases energy efficiency and reduces noise pollution. The speed can be adjusted mechanically and, depending on the task type, the transporter conveys, sorts or separates electrically.

Used predominantly in the food and pharmaceutical industries.

Material:

made from stainless steel and anodised aluminium

Order example:

Order numbers for electric transporter
CLEAN LINE, MINI

without connection cable (2299.60.82.0x.xx)

2299.61.18100.00 **without** Control unit, 230 V

2299.61.18100.01 **with** Control unit, 230 V

Max. transport weight (excl. channel)	10 kg
Max. channel weight	4 kg
Stroke length	20 mm
Conveying speed (mechanically adjustable)	4 - 8 m/min.
Warning system (motion sensor)	integrated
Start/stop	Controllable via PLC
Motor and overload protection	integrated
Noise emissions	60 dB (A)
Power consumption	0.05 kW
Electrical connection, control unit	M23
Protection type	IP66
Dimensions (LxBxH)	271 mm x 118 mm x 38 mm
Weight	2.65 kg
Temperature operating range (environment temperature)	-20 bis +100 °C

The connection cable, control unit transporter and optionally the signal cable, control unit press are to be ordered separately. For more information on the electrical connection, control unit and guide channel, see Accessories.

Socket head screws DIN ISO 4762 M6x40 (x 4) stainless steel A2 for fastening the transporter are included in delivery.

TRANSPORTER ELECTRICAL CLEAN LINE, COMPACT

2299.61.14100.

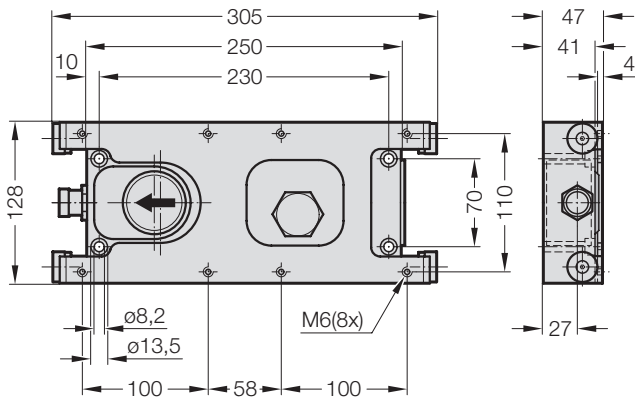

Description:

The electric transporter simplifies automation, increases energy efficiency and reduces noise pollution. The speed can be adjusted mechanically and, depending on the task type, the transporter conveys, sorts or separates electrically.

Used predominantly in the food and pharmaceutical industries.

Material:

made from stainless steel and anodised aluminium

Order example:

Order numbers for electric transporter
CLEAN LINE, COMPACT

without connection cable (2299.60.82.0x.xx)

2299.61.14100.00 **without** Control unit, 230 V

2299.61.14100.01 **with** Control unit, 230 V

Max. transport weight (excl. channel)	20 kg
Max. channel weight	8 kg
Stroke length	20 mm
Conveying speed (mechanically adjustable)	4 - 8 m/min.
Warning system (motion sensor)	integrated
Start/stop	Controllable via PLC
Motor and overload protection	integrated
Noise emissions	60 dB (A)
Power consumption	0.07 kW
Electrical connection, control unit	M23
Protection type	IP66
Dimensions (LxBxH)	305 mm x 128 mm x 47 mm
Weight	3.7 kg
Temperature operating range (environment temperature)	-20 up to +100 °C

The connection cable, control unit transporter and optionally the signal cable, control unit press are to be ordered separately. For more information on the electrical connection, control unit and guide channel, see Accessories.

Socket head screws DIN ISO 4762 M8x50 (x 4) stainless steel A2 for fastening the transporter are included in delivery.

TRANSPORTER ELECTRICAL CLEAN LINE, MAX

2299.61.12100.

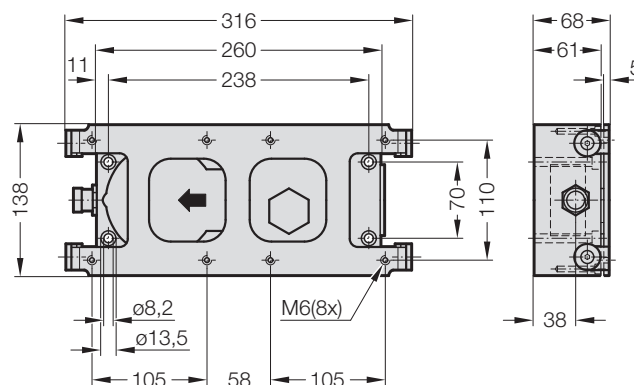

Description:

The electric transporter simplifies automation, increases energy efficiency and reduces noise pollution. The speed can be adjusted mechanically and, depending on the task type, the transporter conveys, sorts or separates electrically. Used predominantly in the food and pharmaceutical industries.

Material:

made from stainless steel and anodised aluminium

Order example:

Order numbers for electric transporter
CLEAN LINE, MAX

without connection cable (2299.60.82.0x.xx)

2299.61.12100.00 **without** Control unit, 230 V

2299.61.12100.01 **with** Control unit, 230 V

Max. transport weight (excl. channel)	40 kg
Max. channel weight	16 kg
Stroke length	20 mm
Conveying speed (mechanically adjustable)	4 - 8 m/min.
Warning system (motion sensor)	integrated
Start/stop	Controllable via PLC
Motor and overload protection	integrated
Noise emissions	60 dB (A)
Power consumption	0.15 kW
Electrical connection, control unit	M23
Protection type	IP66
Dimensions (LxBxH)	316 mm x 138 mm x 68 mm
Weight	6.3kg
Temperature operating range (environment temperature)	-20 up to +100 °C

The connection cable, control unit transporter and optionally the signal cable, control unit press are to be ordered separately. For more information on the electrical connection, control unit and guide channel, see Accessories.

Socket head screws DIN ISO 4762 M8x70 (x 4) stainless steel A2 for fastening the transporter are included in delivery.

TRANSPORTER ELECTRICAL – ACCESSORIES

CONTROL UNIT CLEAN LINE, SIGNAL CABLE, CONNECTION CABLE

2299.61.1□100.12 – CONTROL UNIT CLEAN LINE

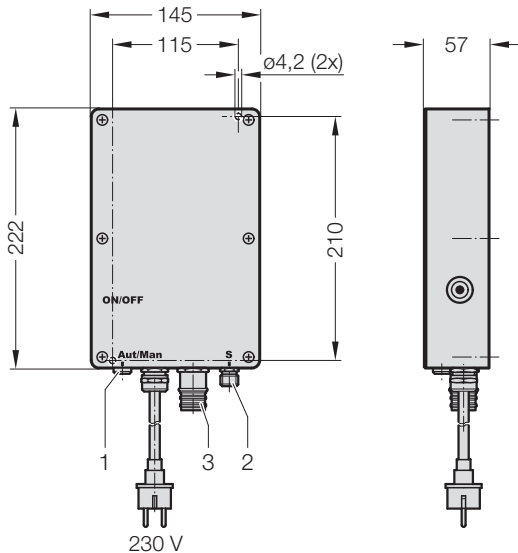

Order No	Connection	Power requirement
2299.61.12100.12	230 V	1,2 - 2,2 A
2299.61.14100.12	230 V	0,75 - 1,7 A
2299.61.18100.12	230 V	0,55 - 1,3 A

1-phase 110-230 V, 50-60 Hz, earthed connection

Description:

The control unit is the electrical module for controlling the transporter.

Note:

The control unit must be mounted on a metal surface for heat dissipation. Before connecting the electric transporter, check that the channel can move freely in the direction of travel.

Included in the delivery,

Mains connection incl. plugs for USA and GB,

Fixing bolts DIN EN ISO 4762 M4 x 20 (x 2) stainless steel A2

Material:

Aluminium die casting

IP67

Technical specifications:

Temperature operating range: -20 to +40 °Celsius
(environment temperature)

1 - Changeover between PLC and manual operation



PLC mode:

In this position, this start/stop function is controlled via the straight signal cable (M12 plug).



Manual mode:

In this position, the start/stop function is controlled by the control unit.

2 - 2299.60.81.01. Signal cable straight, to the press order separately

Order No	l [m]
2299.60.81.01.03	3
2299.60.81.01.05	5
2299.60.81.01.10	10

For further information, see catalogue page for straight signal cable

3 - 2299.60.82.01. Connection cable straight/straight, control unit - transporter order separately

Order No	l [m]
2299.60.82.01.03	3
2299.60.82.01.05	5
2299.60.82.01.10	10
2299.60.82.01.15	15

2299.60.82.02. Connection cable straight/90°, control unit - transporter order separately

Order No	l [m]
2299.60.82.02.03	3
2299.60.82.02.05	5
2299.60.82.02.10	10
2299.60.82.02.15	15

TRANSPORTER ELECTRICAL – ACCESSORIES

SIGNAL CABLE STRAIGHT, TO THE PRESS

2299.60.81.01.



Description:

The signal cable connects the control unit to the power press/production machine.

Order No	l [m]
2299.60.81.01.03	3
2299.60.81.01.05	5
2299.60.81.01.10	10

Assignment:

M12 - Plug
4-pin /
A-coded

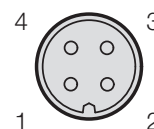

1 (brown)	= Start/stop	Digital input 24 V DC	= Start
2 (white)	= Fault	Digital output 24 V DC	= Fault
3 (blue)	= 0 V DC	Together 0 V DC	= 0 V
4 (black)	= Control unit	Digital output 24 V DC	= OK

Conditions	Output	
	Pin 2	Pin 4
Fault	24 V / (+) 24 V*	0 V
OK	0 V	24 V / (+) 24 V*
Conditions	Input	
	Pin 1	Pin 3
started	24 V / (+) 24 V*	- 0 V
stopped	0 V	- 0 V

* for control unit with potential-free output

TRANSPORTER ELECTRICAL – ACCESSORIES

SEALING CAP

2299.60.82.04.1



Description:

Sealing cap for electric transporter - control unit connection

Material:

Nickel-plated copper/zinc alloy

Material:

Sealing cap incl. M4x6 pan head bolt and connection chain

IP67 in mounted position

2299.60.82.04.2



Description:

Sealing cap for connection cable 2299.60.82.01./02.

Material:

Nickel-plated copper/zinc alloy

Note:

Sealing cap incl. connection chain

IP67 in mounted position

TRANSPORTER ELECTRICAL – ACCESSORIES

CHANNEL FASTENING STANDARD

CHANNEL FASTENING INCL. SLOT STONE

2299.69.10.1□. – Channel fastening standard

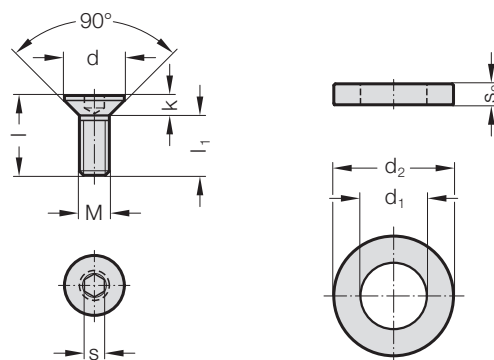

Description:

The standard channel fastening is a mounting kit for fastening the channel directly to the electric transporter. It consists of 4 flat head screws and 4 washers, self-adhesive.

Material:

2299.69.10.10. Steel, zinc-plated
2299.69.10.11. Stainless steel A2

Order No	M	d	k	l	l ₁	s	d ₁	d ₂	s ₂	for electric transporter
2299.69.10.10.05	M5	10	2.8	8	5.2	3	13.3	24	4.2	2299.60.18100.
2299.69.10.10.06	M6	12	3.3	10	6.7	4	13.3	24	4.2	2299.60.12100./14100.
2299.69.10.10.06.012	M6	12	3.3	12	8.7	4	13.3	24	4.2	2299.60.10100.
2299.69.10.11.05	M5	10	2.8	8	5.2	3	13.3	24	4.2	2299.61.18100.
2299.69.10.11.06	M6	12	3.3	10	6.7	4	13.3	24	4.2	2299.61.12100./14100.

Note:

Gutter fastening can be used for gutters with sheet thickness < 1.5 mm.

2299.69.10.20 – Channel fastening incl. slot stone

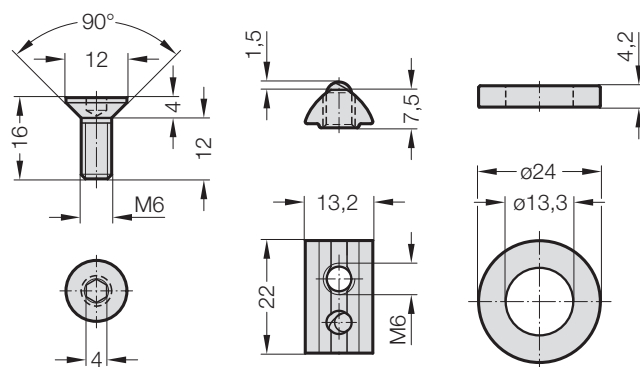

Description:

The channel fastening, incl. slot stone, is a mounting kit for fastening the channel on the profiled beam. It consists of four slot stones, four countersunk screws and four washers, self-adhesive, which allows continuous adjustment of the channel on the profiled beam after mounting.

Material: Steel, zinc-plated

Note: 2299.69.10.20 use only for electric transporter, BLACK LINE 2299.60.10100., 2299.60.12100. and 2299.60.14100.

TRANSPORTER ELECTRICAL – ACCESSORIES

MOUNTING TOOL

2299.69.10.00.01.05 / 2299.69.10.00.01.06



Application example:

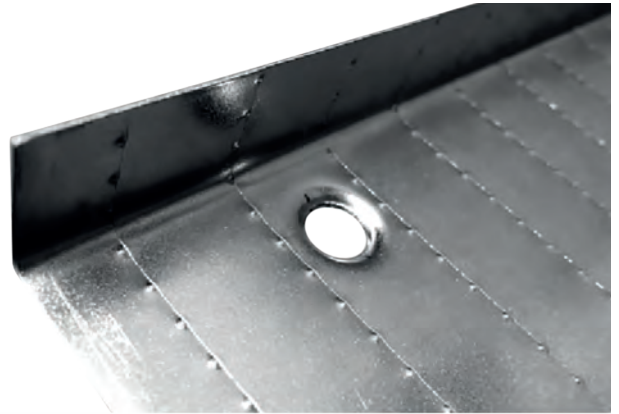

Description:

The mounting tool is used for chamfering the mounting holes in the channel.

Note:

2299.69.10.00.01.05 use only for electric transporter
BLACK LINE 2299.60.18100.
CLEAN LINE 2299.61.18100.

2299.69.10.00.01.06 use only for electric transporter
BLACK LINE 2299.60.10100.
BLACK LINE 2299.60.12100.
CLEAN LINE 2299.61.12100.
BLACK LINE 2299.60.14100.
CLEAN LINE 2299.61.14100.

TRANSPORTER ELECTRICAL – ACCESSORIES

CHANNEL FASTENING TOPMOUNT

CHANNEL FASTENING UNDERMOUNT

2299.69.10.30 – CHANNEL FASTENING TOPMOUNT

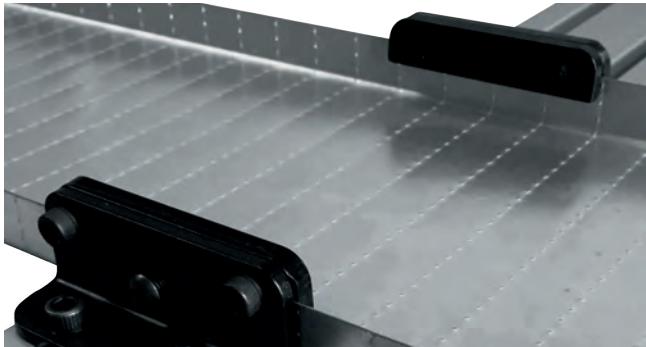

Description:

The topmount channel fastening, with its simple clamping principle, allows flexible mounting of the channel (without additional processing) on the top of the 2299.69.20.80 profiled beam.

2299.69.10.40 –

CHANNEL FASTENING UNDERMOUNT

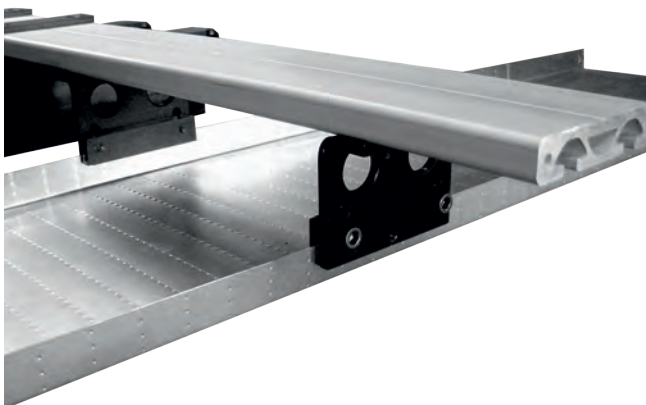

Description:

The undermount channel fastening, with its simple clamping principle, allows flexible mounting of the channel (without additional processing) underneath the 2299.69.20.80 profiled beam, as well as mounting of the electric transporter at the same construction height.

2299.69.10.30

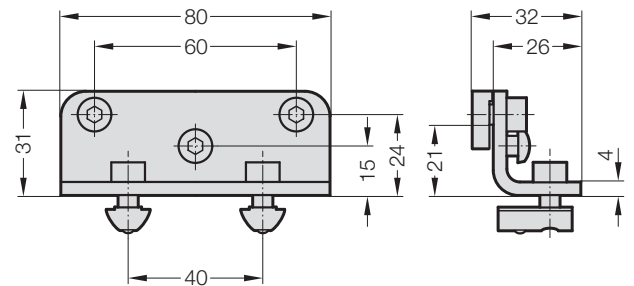

Material:

High-strength steel, black zinc-plated
Weight: 0.4 kg (per pair)

Note:

Included in the scope of delivery are the topmount channel fixings, in pairs, socket head screws and slot stones.
Construction height above beam: 30 mm

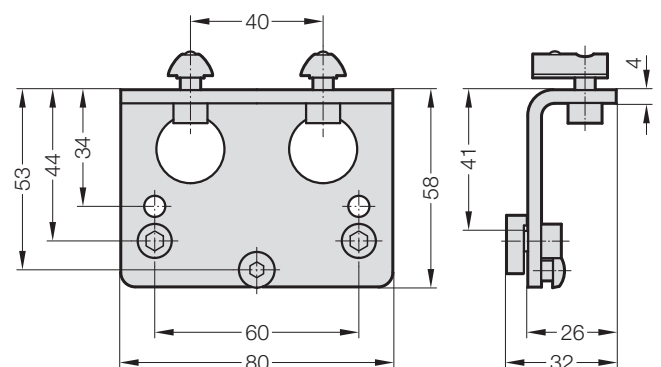

Material:

High-strength steel, black zinc-plated
Weight: 0.6 kg (per pair)

Note:

Included in the scope of delivery are the undermount channel fastenings, in pairs, socket head screws and slot stones.
Construction height below beam: 58.5 mm

TRANSPORTER ELECTRICAL – ACCESSORIES

PROFILED BEAM RETAINER BAR

2299.69.20.80. – PROFILED BEAM

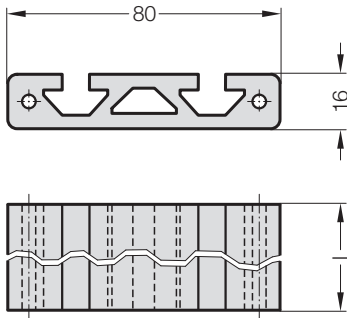

Description:

Flexible set-up of multiple channel sections is possible using the profiled beam.

Material:

Aluminium, anodised (corrosion-resistant)
Weight: 2.2 kg/m

Order No	l [mm]
2299.69.20.80.1000	1000
2299.69.20.80.2000	2000

Note:

Only use for transporter,
BLACK LINE 2299.60.10100./12100./14100.
Profiled shape SP3100N profile 8 16 x 80
For fastening the profiled bar onto the electric transporter, the 2299.69.20.02.06 flat head screw (M6x20) or the 2299.69.20.01.06 retainer strip must be ordered separately.

2299.69.20.01.06 – RETAINER BAR

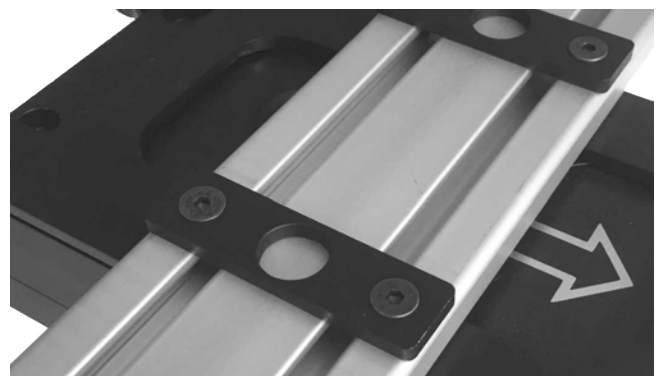
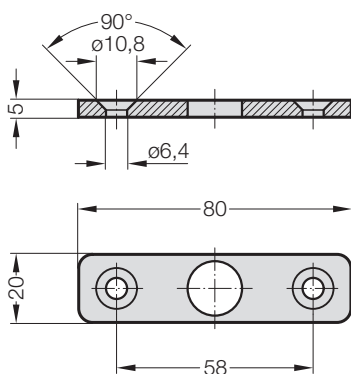

Description:

The retainer bar is used to fasten the 2299.69.20.80 profiled bar to the electric transporter.

Material:

High-strength steel, black zinc-plated
Weight: 0.16 kg/per pair

Note:

Included in the scope of delivery are two retainer bars with 4 x flat head screws ISO 10642 - 8.8 M6x20.
Only use for
transporter, electric BLACK LINE
2299.60.10100./12100./14100.

TRANSPORTER ELECTRICAL – ACCESSORIES

CLAMPING BAR

2299.69.30.



2299.69.30.1000

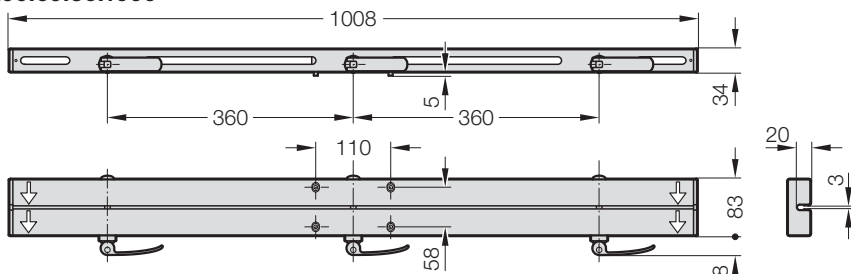

2299.69.30.1500

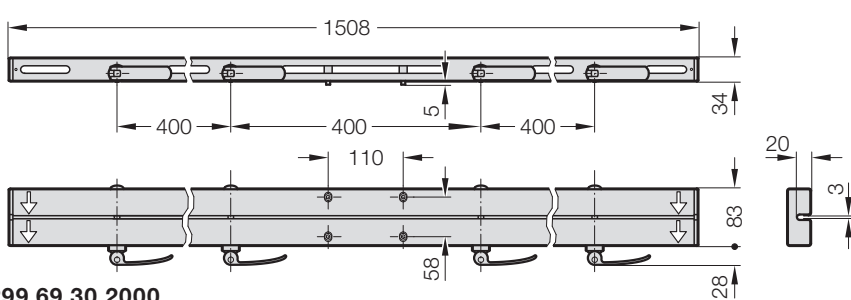

2299.69.30.2000

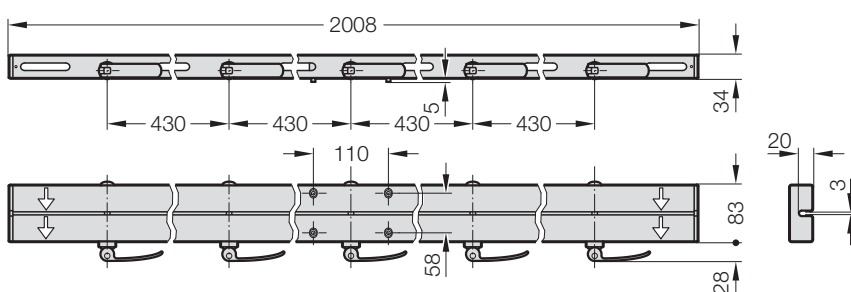

Description:

The clamping bar is used for rapid changeover between multiple transport channels.

The mechanical clamping lever securely clamps the channel to the 2299.69.30.00.01.1230 angled profile in the slot without tools.

Material:

High-strength steel (laser-cut),
Black zinc-plated

Order No	for electric transporter	Weight [kg] Clamping bar
2299.69.30.1000	2299.60.10100.00/ 2299.60.12100.00	2.5
2299.69.30.1500	2299.60.10100.00/ 2299.60.12100.00	4.5
2299.69.30.2000	2299.60.10100.00/ 2299.60.12100.00	6.5

TRANSPORTER ELECTRICAL – ACCESSORIES

ANGLED SECTION FOR CLAMPING BAR

2299.69.30.00.01.1230

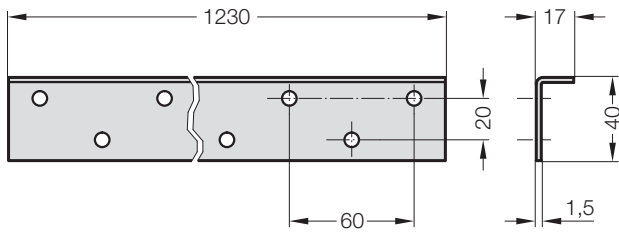

Description:

Angled section for welded connection underneath the channel when using the clamping bar.

Material:

High-strength steel

Note:

Dimensions: 1230 mm x 17 mm x 40 mm

Weight: 0.7 Kg

Only use for 2299.60.10100./2299.60.12100.

Electric transporter, BLACK LINE, ULTRA/MAX

TRANSPORTER ELECTRICAL – ACCESSORIES

HEIGHT-ADJUSTABLE MOUNTING BRACKET

2299.69.40

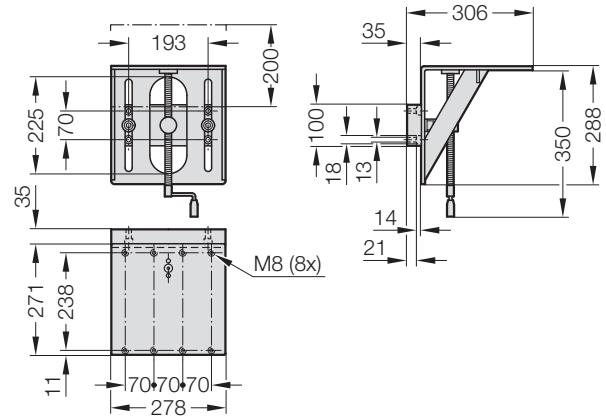

Description:

The height-adjustable mounting bracket is attached to the power press/production machine using four bolts. The mounting bracket has three pre-defined mounting options on the top (left, centre and right) for the transporter.

Material:

Steel, black zinc-plated

Max. load	100 kg
Height adjustment of the angled support (with ball bearing-mounted crank)	200 mm
Weight	18,2 kg

Note:

Only use for 2299.60.10100./2299.60.12100.
Electric transporter, BLACK LINE, ULTRA/MAX
Included in the delivery scope: socket head screws
DIN EN ISO 4762 4x M12x50 -12.9.

TRANSPORTER ELECTRICAL – ACCESSORIES

HEIGHT-ADJUSTABLE MOUNTING BRACKET, FOR BEAM MOUNTING

2299.69.41

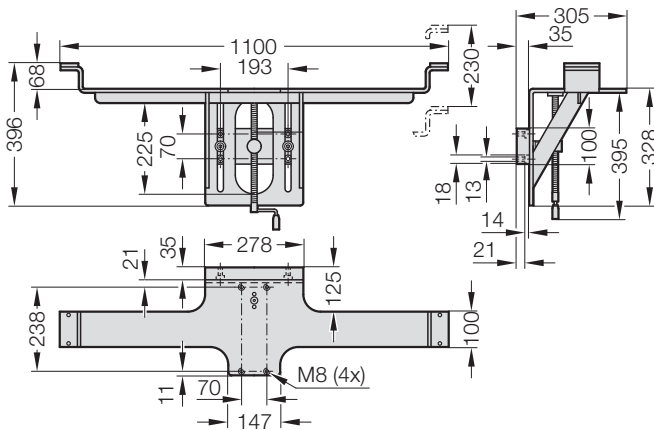

Description:

The height-adjustable mounting bracket is attached to the power press/production machine using four bolts. The lateral outriggers prevent the profiled beam from bending with a larger span.

Material:

Steel, black zinc-plated

Note:

Only use for 2299.60.10100./12100.

Electric transporter, BLACK LINE, ULTRA/MAX

Replacement slide element: 2299.69.41.00.01

Included in the delivery scope: socket head screws

DIN EN ISO 4762 4x M12x50 -12.9.

Max. load	100 kg
Max. length of aluminium bar	3000 mm
Max. length of clamping bar	2000 mm
Height adjustment of the angled support (with ball bearing-mounted crank)	230 mm
Weight	28.5 kg

Further information at

www.fibro.de/en/electrictransporterblacklinecleanline/



FIBRO GMBH

Business Unit Normalien
August-Läpple-Weg
74855 Hassmersheim
GERMANY
T +49 6266 73-0
info@fibro.de
www.fibro.com

THE LÄPPLE GROUP

LÄPPLE AUTOMOTIVE
FIBRO
FIBRO LÄPPLE TECHNOLOGY
LÄPPLE AUS- UND WEITERBILDUNG