

# OPERATING INSTRUCTIONS

## CONTROL UNIT CLEAN LINE

2299.61.12100.12 / 2299.61.14100.12 / 2299.61.18100.12



Document: Operating instructions

Document number: 2.7832.00.0920.0100000

Revision: R09-2020

Version: V01

Language:



In the German language, this document is the original version in the EU language of the manufacturer and is labelled with the German national flag.

In the language of a country of use, this document is a translation of the original version and labelled with the national flag of the country of use.

This document is referred to as "instructions" in the following text.

Number of pages in this manual including the title page: 24

These instructions are valid for the product

2299.61.12100.12 / 2299.61.14100.12 / 2299.61.18100.12

Control unit CLEAN LINE

This document was created by

FIBRO GMBH

August-Läpple-Weg

DE 74855 Hassmersheim

Phone: +49 (0) 62 66 73 0

Fax: +49 (0) 62 66 73 237

E-mail: [info@fibro.de](mailto:info@fibro.de)

Internet: [www.fibro.de](http://www.fibro.de)

© All rights to this document are subject to copyright of the author.

Without the prior written permission of FIBRO GMBH, this document must not be copied or reproduced, either in full or in part.

The instructions are intended only for the operator of the described Control unit only and must therefore not be made available to uninvolved third parties - in particular to competitors.

## Contents

<b>1</b>	<b>Introduction</b>	<b>4</b>
1.1	Definition	4
1.2	Intended use	4
1.3	Limits of use	4
1.4	Foreseeable misuse	5
1.5	Warranty	5
1.6	Manual	5
1.6.1	Target group	5
1.6.2	Legend	6
1.6.3	Figures	6
1.6.4	Safety instructions	7
1.6.5	General instructions	7
<b>2</b>	<b>Safety</b>	<b>8</b>
2.1	Safety information	8
2.1.1	Due diligence of the operator	8
2.1.2	Qualifications of personnel	9
2.1.3	Personnel requirements	9
2.2	Residual risks	10
<b>3</b>	<b>Product description</b>	<b>11</b>
3.1	Components	11
3.2	Function	12
3.3	Technical data	12
3.3.1	Type plate	13
3.4	Accessories	14
<b>4</b>	<b>Transport</b>	<b>15</b>
4.1	Transport damage	15
4.2	Interim storage	15
4.3	Return shipping	15
4.4	Disposing of the packaging material	15
<b>5</b>	<b>Assembly</b>	<b>16</b>
<b>6</b>	<b>Operation</b>	<b>17</b>
<b>7</b>	<b>Indexes</b>	<b>18</b>
7.1	Index of figures	18
7.2	Index of tables	18
<b>8</b>	<b>Appendix</b>	<b>19</b>
8.1	Declaration of conformity	19
8.2	Personal notes	21
<b>9</b>	<b>Index</b>	<b>23</b>

# 1 INTRODUCTION

## 1.1 Definition

The product Control unit CLEAN LINE is electrical equipment as defined in European Directive 2014/35/EU.

## 1.2 Intended use

The product is electrical equipment for use at a rated voltage between 50 VAC and 1000 VAC. FIBRO GMBH has no influence on the intended use of the product.

It can only be used within the defined limits.

Proper use also includes:

- Reading these instructions.
- Complying with the safety information they contain.
- Complying with the other applicable documents.

## 1.3 Limits of use

Operating conditions	The product is designed for industrial use and is not suitable for private use.
Food industry	The product is suitable for use in the food industry.
Pharmaceutical industry	The product is suitable for use in the pharmaceutical industry.
Service life	The service life of the product is 15.000 operating hours.
Temperature range Operation	Permissible temperature rang for operation: -20 °C...+40 °C.
Storage temperature range	Permissible temperature range for storage: -20 °C...+40 °C.
ATEX	The product is not suitable for operation in an environments with explosive atmospheres, gases or radiation.

## 1.4 Foreseeable misuse

Every type of use of this product beyond the proper use shall be considered misuse and is prohibited.

The product must not be stressed beyond its load limits.

The following instances, among others, are considered misuse:

- Operation outside the permissible technical data (see chapter 3.3 "Technical data" on page 12).
- Operation in potentially explosive atmospheres.

## 1.5 Warranty

The guarantee is regulated contractually (see Terms and Conditions or contract)

## 1.6 Manual

These instructions describe how to use the product and contain important information on proper use.

A copy of these instructions must always be kept by the product and must be read, understood and followed by everyone who works on or with the product.

The safety information in the various different chapters must be observed.

These instructions and other applicable documents are not updated automatically.

We reserve the right to make changes to the data and images in these instructions in the course of further technical development.

FIBRO GMBH can supply the current issue.



These instructions must be kept throughout the entire operating life of the product. One copy of these instructions must be available to the user directly and be read carefully before using the product.

Incomplete instructions must be supplemented. Illegible pages must be replaced.

### 1.6.1 Target group

Target groups of this manual are

- Specialists
- Trained personnel
- Instructed personnel

Tasks and the required qualification of the personnel are defined in chapter 2.1.2 "Qualifications of personnel" on page 9.

## 1.6.2 Legend

Characters, symbols and abbreviations are used in these instructions in order to clearly represent the content. They have the following meaning:

- 1) Marks the first level of an itemisation
  - a) Marks the second level of an itemisation
- Marks the first level of a list
  - Marks the second level of a list
- ✓ Contains information on requirements which have to be fulfilled before executing handling instructions.
- ✘ Contains information on tools, operating materials or tools required for the execution of repair work.



The book symbol before a text is a reference to a related document or another chapter of these instructions. The content of this document or the chapter must be taken into account.



The information symbol before a text marks a supplementary note or an important application tip.

## 1.6.3 Figures

The figures in these instructions are examples. Deviations between a figure and the actual conditions on the Control unit are possible.

The drawings of FIBRO GMBH and the information on third-party products are decisive.

## 1.6.4 Safety instructions

These instructions contain safety notices intended to draw attention to possible dangers that should be observed to prevent injury.

The pertinent text describes

- the type of danger
- the source of danger
- the options for preventing injuries
- the consequences in case of non-observance of the warning notices

The safety instructions are emphasised by a colour signal bar with warning triangle and signal word.

The signal bars have the following meaning:

 **DANGER!**

**A safety notice on a red signal bar with the signal word DANGER designates a hazard with a high risk level which, if not avoided, will result in death or severe injury.**

 **WARNING!**

**A safety notice on an orange signal bar with the signal word WARNING designates a hazard with a medium risk level which, if not avoided, might result in death or severe injury.**

 **CAUTION!**

**A safety notice on a yellow signal bar with the signal word CAUTION designates a hazard with a low risk level which, if not avoided, could result in minor or moderate injury.**

## 1.6.5 General instructions

In addition to the safety notices, these instructions contain information that must be observed to prevent property damage.

The pertinent text describes

- the possible reason for property damage
- the possibilities for preventing property damage

Notices of possible property damage are emphasised by a blue signal bar and the signal word *ATTENTION*.

**NOTICE**

**Notices for the prevention of property damage are not related to possible injuries.**



Furthermore, these instructions contain general information on use.

General information on use and tips for certain applications are emphasised with a blue information symbol.

## **2 SAFETY**

### **2.1 Safety information**

#### **2.1.1 Due diligence of the operator**

This product has been designed and constructed by FIBRO GMBH in line with the latest technological standards. All health and safety requirements for maintaining safety are met.

Safety can only be achieved in practice when all the required measures are taken. The company operating the product must plan these measures and check that they have been implemented.

The operating company is responsible for the safe operation of the product.

The operating company must ensure that:

- The product is only used correctly.
- The product is only used when it is in a faultless condition and fully functional and when the required mechanical and electrical safety devices are in place.
- A legible, complete copy of these instructions and any other applicable documents must always be kept by the product. It must be ensured that anyone working on the product can view these instructions at any time.
- Only personnel as described in the chapter 2.1.2 "Qualifications of personnel" work on the product.
- The personnel have read and follow the instructions and, in particular, the safety information.
- The responsibilities of the personnel are clearly defined and complied with.
- The personnel are regularly instructed regarding all relevant health and safety and environmental protection issues.
- All safety and warning information attached to the product is not removed and remains legible.
- Operating instructions on safety at work and accident prevention are issued.
- National accident prevention regulations and internal company requirements are complied with.
- Personal protective clothing is available where necessary.



## 2.1.2 Qualifications of personnel

For certain areas of responsibility, special qualification of the personnel is required.

Among other things, knowledge of first aid measures and local rescue facilities is required.

Operation	Instructed personnel
Troubleshooting	Trained personnel
Change of control parameters	Qualified personnel

Qualified personnel are persons who, due to their training, experience and instruction as well as their knowledge of relevant standards, regulations, accident prevention rules and operating conditions, are qualified to carry out the required activities and are able to recognise and avoid possible hazards.

Trained personnel are persons who have been trained for a specific task by the manufacturer or operator. Trained personnel are qualified to perform the activities corresponding to their level of knowledge achieved during training. Trained personnel have been made aware of potential hazards and can recognise and avoid them.

Instructed personnel are persons who have been authorised by the manufacturer or operator to perform certain tasks independently.

## 2.1.3 Personnel requirements

The following safety information must be observed when working on or with the product described in these instructions. Disregarding the safety information may result in death or serious injuries.

The personnel must have the required training, experience and in order to be able to work on the product correctly. Improperly carried out work on the product can be dangerous and result in death or serious injuries.

No work may be carried out unless the information on it in these instructions and other applicable documents has been read and understood.

If a tool, activity, working method or practice is not expressly suggested by FIBRO GMBH, users must ensure it is safe both for themselves and others.

It must also be ensured that the product is not damaged or made unsafe by the intended work.

Everyone who works on or with the product must:

- Have read and understood these instructions.
- Comply with the safety information in these instructions.
- Heed the danger signs on the product.
- Heed the warnings in these instructions about possible residual risks.
- Ensure that there are no unauthorised persons near the product.
- Follow not only these instructions but also the instructions issued by the operating company on safety at work and accident prevention.
- Inform the operating company or a supervisor if a malfunction occurs.
- Immediately notify the manager responsible if there are any changes to the product that may diminish safety.

## 2.2 Residual risks

Dangers that cannot be completely eliminated through design and/or control-technical measures present a residual risk.

A safety notice in the relevant chapters and before certain handling steps in these instructions draw attention to residual risks.

For the colour coding and structure of the individual safety notices, see chapter 1.6.4 "Safety instructions" on page 7.

In addition to the information in the chapters, the safety notices to be observed for a safe handling of the Control unit are summarised as follows.



### **WARNING!**

#### **Ignition of an explosive atmosphere**

Ignition hazards arising from a product may ignite an explosive atmosphere and cause an explosion.

- ▶ The product is not suitable for use in explosion hazard areas.
- ▶ Use in explosion hazard areas is prohibited.
- ▶ Serious through to fatal injuries due to the consequences of an explosion.



### **WARNING!**

#### **It is forbidden for non-qualified staff to perform any activities on the machine.**

Activities on or with the product sometimes require that the staff has certain qualifications (see chapter 2.1.2 "Qualifications of personnel" on page 9).

- ▶ These activities can only be performed by staff which is qualified for these activities and is authorised to do so by the operator.
- ▶ If unqualified or non-authorized staff works on the system, injuries can be caused by improper handling.

## 3 PRODUCT DESCRIPTION

### 3.1 Components

#### **Available models:**

- Control unit CLEAN LINE 2299.61.18100.12
  - Control of an electrical transporter CLEAN LINE MINI 2299.61.18100.00
- Control unit CLEAN LINE 2299.61.14100.12
  - Control of an electrical transporter CLEAN LINE COMPACT 2299.61.14100.00
- Control unit CLEAN LINE 2299.61.12100.12.
  - Control of an electrical transporter CLEAN LINE MAX 2299.61.12100.00

#### **System**

The product consists of:

- Control unit
- Mains connection cable including connector for USA and GB
- Two fastening screws ISO 7380-1 M6 x 8

Pre-assembled cables for connecting the control unit of an electrical transporter and an external device are optional and must be ordered separately (see chapter 3.4 "Accessories" on page 14).

#### **Control unit CLEAN LINE**



Fig. 3-1 Components of control unit CLEAN LINE

- 1 Control unit
- 2 Mains connection cable
- 3 On / Off switch
- 4 Automatic / Manual changeover switch
- 5 Signal cable connection socket (communication with the PLC of an external device)
- 6 Connection cable connection socket (connection of an electrical transporter)

**Equipment**

The control unit contains engine and overload protection as well as an alarm device for interruptions in operation. Should, when operating the electrical transporter, a fault occur, a fault signal is sent via the connection socket of the signal cable.

**3.2 Function**

The control unit is the electrical module for controlling an electrical transporter.

The control unit provides a sensor-controlled power supply to the electrical transporter.

In combination with a signal cable, control commands for an electrical transporter can also be received and processed by the PLC of an external device.

**3.3 Technical data**

**Dimension of control unit CLEAN LINE**

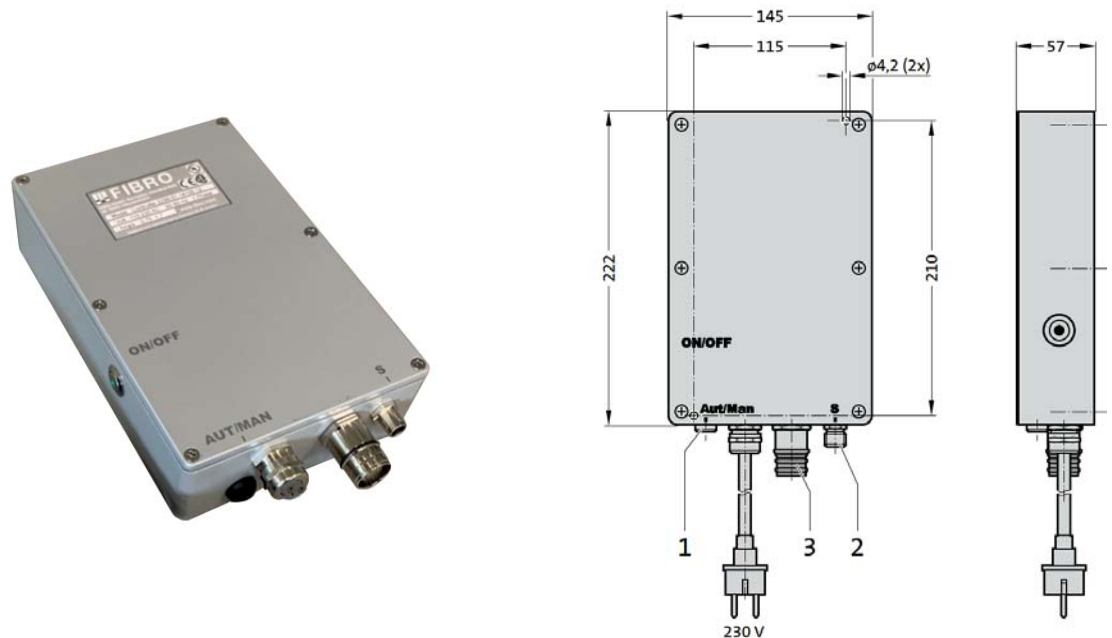

Fig. 3-2 Dimensions of control unit CLEAN LINE

**Connection values**

Control	Voltage [VAC]	Energy requirements [A]
2299.61.12100.12	110...230*	1.2...2.2
2299.61.14100.12	110...230*	0.75...1.7
2299.61.18100.12	110...230*	0.55...1.3

\*Single phase, 50-60 Hz, grounded connection

Tab. 3-1 Connection values of control unit CLEAN LINE

**Digital inlets / outputs**

Signal exchange with an external device is executed via the connection socket for the signal cable.

PIN	Type	Value	Function
	1	+24 VDC	Start
		0 VDC	Stop
	2	+24 VDC	Error
		0 VDC	OK
3	Common connection	--	Minus
4	Digital outlet	+24 VDC	Control OK
		0 VDC	Control error

Tab. 3-2 PIN assignment of digital inlets / outlets

**3.3.1 Type plate**



A type plate is attached to the control unit. The information on the type plate must be provided for all questions and orders.



Fig. 3-3 Type plate

### 3.4 Accessories

**2299.60.82.01. Connection cable, straight - straight**

The connection cable connects the control unit to an electrical transporter.



Fig. 3-4 Connection cable

Order number	Length [m]
2299.60.82.01.03	3
2299.60.82.01.05	5
2299.60.82.01.10	10
2299.60.82.01.15	15

Tab. 3-3 Connection cable, straight - straight

**2299.60.82.02 connection cable, straight - 90°**

The connection cable connects the control unit to an electrical transporter.

Order number	Length [m]
2299.60.82.02.03	3
2299.60.82.02.05	5
2299.60.82.02.10	10
2299.60.82.02.15	15

Tab. 3-4 Connection cable, straight - 90°

**2299.60.81.01 signal cable**

The signal cable connects the control unit to an external device.



Fig. 3-5 Signal cable

Order number	Length [m]
2299.60.81.01.03	3
2299.60.81.01.05	5
2299.60.81.01.10	10

Tab. 3-5 Signal cable

## **4 TRANSPORT**

### **4.1 Transport damage**

On delivery, the consignment must be checked immediately to ensure that it is complete and has not been damaged in transit. If damage is found on the packaging that indicates possible damage to the contents, the contents must also be inspected for damage.

If damage is found, the transport company must be informed immediately and the transport company must verify the damage.

### **4.2 Interim storage**

- Only store when dry, in its original packaging and in enclosed rooms
- Storage temperature -20 °C...+40 °C
- Maximum humidity 60% (at 25 °C).
- No aggressive substances may be stored in the storage room (acids, bases, solvents etc.).

### **4.3 Return shipping**

For the returns the parts which have to be sent back to the manufacturer for repair have to be packaged securely.

### **4.4 Disposing of the packaging material**

The packaging materials must be either reused or properly disposed of in accordance with the country-specific regulations.

## 5 ASSEMBLY

### NOTICE

#### Product damage

Before mounting, check that the correct control unit has been selected for the respective transporter size.

The control unit must be mounted on a metal surface for heat dissipation.

Before establishing the electrical connection, check that the trough of the controlled transporter can move freely in the direction of travel.

#### Mounting prerequisites:

- ✓ A suitable mounting location is determined.

#### Tool required:

- ✘ Standard tool

1. Drill holes in the mounting surface according to the drilling pattern of the control unit (for drilling pattern, see chapter 3.3 "Technical data" on page 12).
2. Thread the holes.
3. Place control unit on the mounting surface.
4. Screw down the control unit with the supplied fastening screws.

*The control unit is mounted.*

#### Fastening screws for

Type	Screw	Thread
2299.61.1800.12	M4 x 20	M4
2299.61.1400.12	M4 x 20	M4
2299.61.1200.12	M4 x 20	M4

Tab. 5-1 Control unit fastening screws



## 6 OPERATION

### Operating modes

In **AUTOMATIC** operating mode, the start-stop command to the electrical transporter is controlled by the signal of an external device. For this purpose, the control unit must be connected to the external device via the signal cable.

In **MANUAL** operating mode, the start-stop command to the electrical transporter is controlled by the control device. A signal cable is not needed in this case.

### Operating elements



Fig. 6-1 Operating elements of control unit CLEAN LINE

- 1 ON / OFF switch
- 2 AUTOMATIC / MANUAL changeover switch

### Switching on

Switch on control unit by pressing the ON / OFF switch.

### Operating mode selection

Set the operating mode using the AUTOMATIC / MANUAL changeover switch.

Position	Operating mode
	Changeover switch NOT PRESSED: <b>AUTOMATIC</b> operating mode
	Changeover switch PRESSED: <b>MANUAL</b> operating mode

Tab. 6-1 Operating mode selection

### Switching off

Switch off control unit by pressing the ON / OFF switch.

## 7 INDEXES

### 7.1 Index of figures

Fig. 3-1	Components of control unit CLEAN LINE	11
Fig. 3-2	Dimensions of control unit CLEAN LINE	12
Fig. 3-3	Type plate	13
Fig. 3-4	Connection cable	14
Fig. 3-5	Signal cable	14
Fig. 6-1	Operating elements of control unit CLEAN LINE	17

### 7.2 Index of tables

Tab. 3-1	Connection values of control unit CLEAN LINE	12
Tab. 3-2	PIN assignment of digital inlets / outlets	13
Tab. 3-3	Connection cable, straight - straight	14
Tab. 3-4	Connection cable, straight - 90°	14
Tab. 3-5	Signal cable	14
Tab. 5-1	Control unit fastening screws	16
Tab. 6-1	Operating mode selection	17

## **8 APPENDIX**

### **8.1 Declaration of conformity**

Every product falling in the application range of the Directive 2014/35/EU is supplied with a Declaration of Conformity in the context of this Directive.

The Declaration of Conformity certifies FIBRO GMBH the conformity of all requirements from the named Directive relating to the product.

In addition, the Declaration of Conformity contains details on other related directives and observed harmonised standards.

For content of the Declaration of Conformity as well as sources of the applied directives and observed harmonised standards, see next page.







## 9 INDEX

### A

alarm device 12  
ATEX 4  
atmospheres  
    potentially explosive 5

### C

cables  
    pre-assembled 11  
Changes  
    technical 5  
Connection cable 14  
connection cable 14  
Connection values 12  
connector  
    USA and GB 11  
Control unit 11  
Copyright 2

### D

Damage  
    to the contents 15  
    to the packaging 15  
Danger sign 9  
Dangers  
    possible 7  
Declaration of Conformity 19  
device  
    external 11 14  
Digital inlets / outputs 13  
Dimensions 12  
Directive 2006/42/EC 19  
Documents  
    other applicable 5

### E

engine protection 12

### F

Fastening screws  
    control box 16  
fastening screws  
    control box 11  
fault 12  
fault signal 12  
Food industry 4

### H

heat dissipation 16  
Humidity  
    maximum 15

### I

Injuries  
    preventing 7

### M

Mains connection cable 11  
misuse 5  
models  
    available 11  
mounting surface 16

### O

Operating conditions 4  
overload protection 12

### P

Packaging material 15  
Personnel  
    qualified 9  
personnel  
    instructed 9  
    qualification 9  
    trained 9  
Pharmaceutical industry 4

### R

Repair 15  
Returns 15

### S

Safety notices 7  
Service life  
    Operating hours 4  
Signal bar 7  
signal cable 13 14  
Signal exchange 13  
Signal word 7  
Staff  
    qualification 10  
Standard  
    harmonised 20  
standard  
    harmonised 19  
Storage temperature 15

### T

Temperature range  
    Operation 4  
    storage 4  
tools 9  
Transport damage 15

### U

Use  
    proper 4 5  
use  
    proper 5

**More information at**

<https://www.fibro.de/normalien/downloads/pdf-downloads/peripherie/>

---



**FIBRO GMBH**

---

Business Area Standard Parts  
August-Läpple-Weg  
74855 Hassmersheim  
Germany  
T +49 6266 73-0  
info@fibro.de  
www.fibro.com

**THE LÄPPLE GROUP**

---

LÄPPLE AUTOMOTIVE  
FIBRO  
FIBRO LÄPPLE TECHNOLOGY  
LÄPPLE AUS- UND WEITERBILDUNG