

MAINTENANCE INSTRUCTIONS

GAS SPRING DS

2486.22.



Document: Maintenance instructions

Document number: 2.7539.00.0915.0100000

Revision: R04-2020

Version: V01

Language:



In the German language, this document is the original version in the EU language of the manufacturer and is labelled with the German national flag.

In the language of a country of use, this document is a translation of the original version and labelled with the national flag of the country of use.

This document is referred to as "instructions" in the following text.

Number of pages in this manual including the title page: 30

These instructions are valid for the product

2486.22.

Gas spring DS

This document was created by

FIBRO GMBH

August-Läpple-Weg

DE 74855 Hassmersheim

Phone: +49 (0) 62 66 73 0

Fax: +49 (0) 62 66 73 237

E-mail: info@fibro.de

Internet: www.fibro.de

© All rights to this document are subject to copyright of the author.

Without the prior written permission of FIBRO GMBH, this document must not be copied or reproduced, either in full or in part.

The instructions are intended only for the operator of the described only and must therefore not be made available to uninvolved third parties - in particular to competitors.

Contents

1	Safety	4
1.1	Safety information	4
1.2	Safety instructions	5
1.3	General instructions	5
1.4	Residual risks	6
2	Maintenance	7
2.1	Components	7
2.2	Inspection	8
2.2.1	Check gas pressure	8
2.3	Repairs	11
2.3.1	Required spare parts, tools and tool kits	11
2.3.2	Evacuating gas pressure	14
2.3.3	Dismantle gas spring	16
2.3.4	Clean and check components	19
2.3.5	Assemble gas spring	20
2.4	Fill with nitrogen	24
3	Indexes	27
3.1	Third-party products	27
3.2	Glossary	27
3.3	Index of figures	27
3.4	Index	28
4	Appendix	29
4.1	Personal notes	29

1 SAFETY

1.1 Safety information

The statements contained in this document only apply to the maintenance of the stated gas springs and are only for the use by trained and authorised staff.

Staff has to have the necessary training, experience and product knowledge as well as specialist tools in order to carry out maintenance work correctly.

Staff has to have fully read and understood this document prior to carrying out any maintenance work.

Replacement of spare parts without special training or knowledge of the maintenance instructions and without the specialist tools can be dangerous and may lead to accidents causing severe injuries or even death.

Most accidents during maintenance occur due to disregarding the basic safety regulation.

Noticing a potential danger can prevent accidents from happening. Safety information in this document warn about potential risks. FIBRO GMBH can not foresee all situations which may potentially cause risks. The warnings in this document are therefore not all encompassing.

If a work material, an act, a work method or work technique is used which has not been specifically suggested by FIBRO GMBH, then the user has to ensure the safety for himself and other persons.

The information, descriptions and illustrations in this documents are based on the information on the basis of information which was available at the point of creation of this document.

Illustrations show examples of a potential gas spring and are not to scale.

Descriptions, tightening torques, operating pressures, measuring methods, illustrations and other points are subject to change at any time. The changes can have an influence on the component's properties. Prior to starting any work, obtain the currently available information.

1.2 Safety instructions

These instructions contain safety notices intended to draw attention to possible dangers that should be observed to prevent injury.

The pertinent text describes

- the type of danger
- the source of danger
- the options for preventing injuries
- the consequences in case of non-observance of the warning notices

The safety instructions are emphasised by a colour signal bar with warning triangle and signal word.

The signal bars have the following meaning:

 **DANGER!**

A safety notice on a red signal bar with the signal word DANGER designates a hazard with a high risk level which, if not avoided, will result in death or severe injury.

 **WARNING!**

A safety notice on an orange signal bar with the signal word WARNING designates a hazard with a medium risk level which, if not avoided, might result in death or severe injury.

 **CAUTION!**

A safety notice on a yellow signal bar with the signal word CAUTION designates a hazard with a low risk level which, if not avoided, could result in minor or moderate injury.

1.3 General instructions

In addition to the safety notices, these instructions contain information that must be observed to prevent property damage.

The pertinent text describes

- the possible reason for property damage
- the possibilities for preventing property damage

Notices of possible property damage are emphasised by a blue signal bar and the signal word *ATTENTION*.

NOTICE

Notices for the prevention of property damage are not related to possible injuries.



Furthermore, these instructions contain general information on use.

General information on use and tips for certain applications are emphasised with a blue information symbol.

For safe maintenance further, applicable documents are necessary. The information in these documents have to be adhered to.



Gas spring operating instructions



Safety data sheet "Exchange of spare parts"



Operating instructions filling and control fitting.

1.4 Residual risks



WARNING!

Filled gas springs are under high internal pressure.

Before repairing, drain the nitrogen completely.

- ▶ To drain, open the valve carefully and only slightly
- ▶ Wear safety glasses. Eye injuries due to nitrogen leaks
- ▶ After removing the locking screw, never bend directly over the valve. Never direct the fill opening towards persons
- ▶ Only unscrew the valve when there is no more nitrogen flowing out and the piston rod can be pushed in by hand. Injuries due to valve flying out.
- ▶ If assembled incorrectly, parts may be propelled out after filling. Observe the precise installation position of the spare parts. Never direct the piston rod towards persons. Injuries possible due to parts flying out.



WARNING!

Use of incorrect spare parts

Installing the incorrect spare parts results in a loss of safety.

- ▶ After filling with nitrogen, parts may be propelled out due to internal pressure.
- ▶ Before repair, always ensure that the correct set of spare parts is being used.
- ▶ Injuries possible due to parts flying parts.

NOTICE

Damages during repair

Always use protective jaws when clamping a gas spring into a vice. Ensure a clean environment.

- ▶ Grooves, bumps or other damages can cause leakages.
- ▶ Never exercise undue force to the gas spring during repair. Protect against damages.
- ▶ Let nitrogen flow in slowly during the filling process. The valve of the gas spring can be damaged.
- ▶ For the filling process, only use pure nitrogen N₂ of Grade 5.0 purity or higher.

Highest permissible filling pressure: 150 bar (2175 psi).

2 MAINTENANCE

2.1 Components

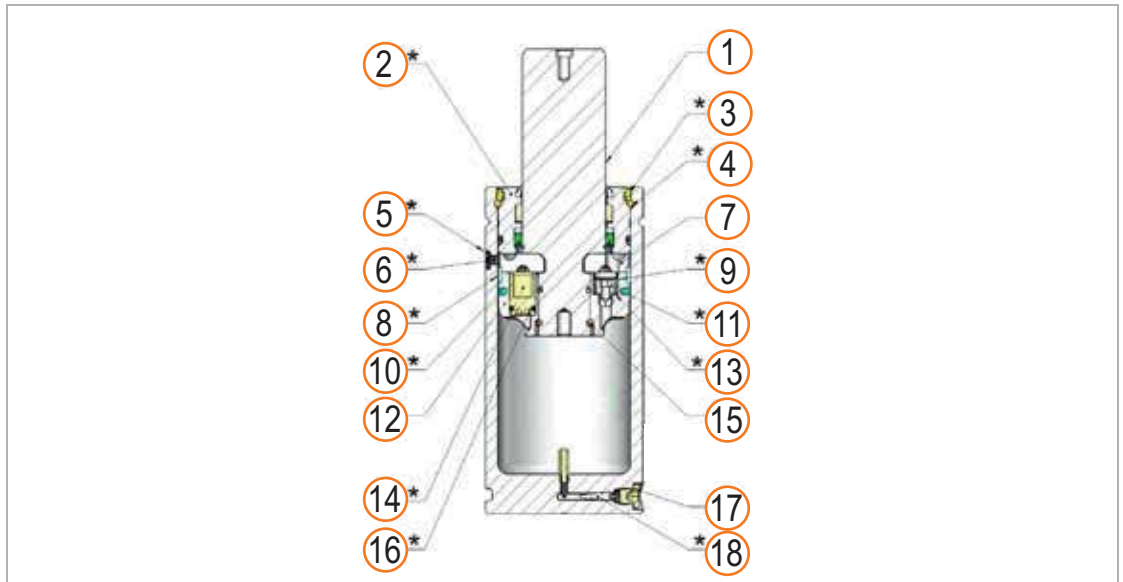

Fig. 2-1 Components of the gas springs

- 1 Piston rod
- 2 Guide
- 3 Dirt ring guard
- 4 Circlip
- 5 Warning tape
- 6 Locking screw on service port
- 7 Separated piston disc
- 8 Guide ring
- 9 Filter screen
- 10 DS piston seal
- 11 Flow restrictor
- 12 DS piston
- 13 Sealing ring
- 14 Non-return valve
- 15 Circlip halves
- 16 DS piston O-ring
- 17 G 1/8 Fill opening locking screw
- 18 Valve



The components marked * are included in the spare parts set.

2.2 Inspection

2.2.1 Check gas pressure

NOTICE

Use the tools given below for the test. The tools are available from FIBRO GMBH. Damage to the gas springs when using other tools.

Pos.	Description	Article number
[A]	Filling and checking equipment	2480.00.32.21
[B]	G1/8" filling adapter	2480.00.32.11
[C]	Filling hose	2480.00.31.02
	Cylinder pressure reducer (optional)	2480.00.32.07

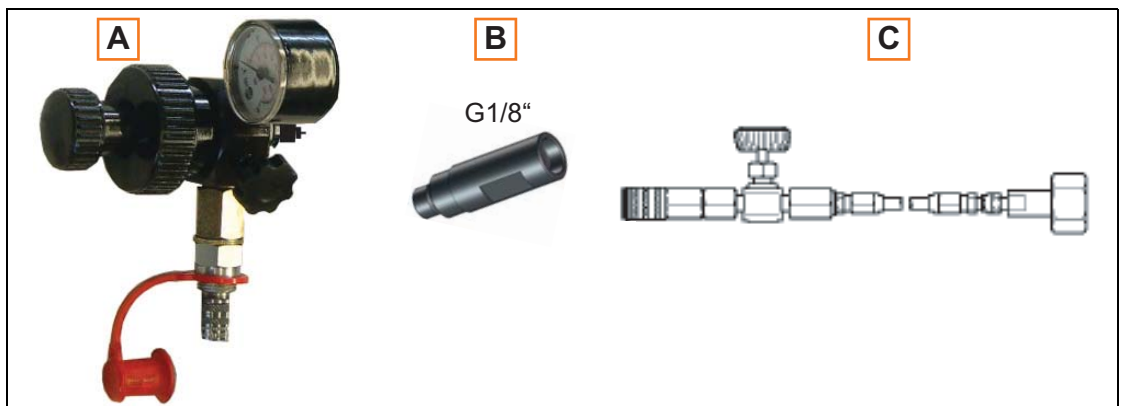

Observe the operating instructions for the filling and checking equipment 2480.00.32.21.

- 1) Prepare filling and checking equipment.
 - Turn the small knob (a) to the left as far as it will go. This will move the release pin (b) into the retracted position.
 - Close the outlet valve (c).
 - Screw the filling adapter onto the M6 thread on the fittings. In the process, ensure that the washer seal is located on the M6 thread.

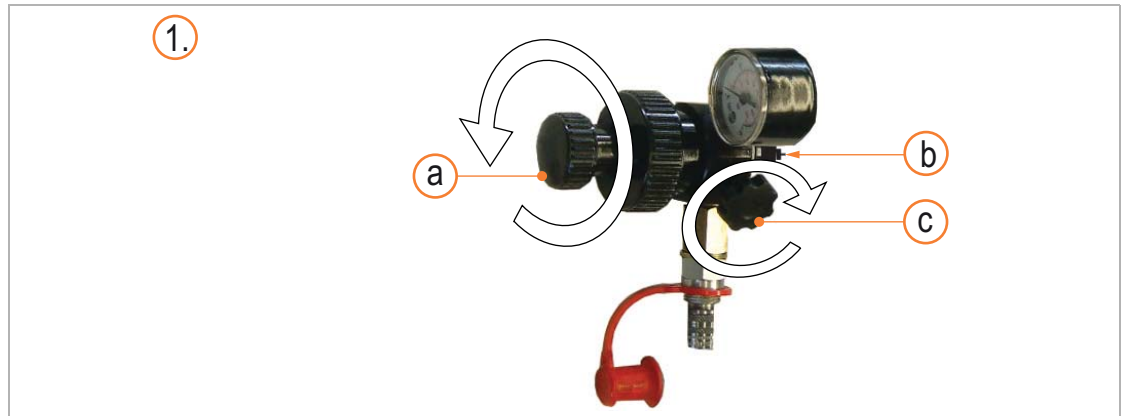

- 2) Carefully unfasten the G1/8" locking screw via the fill opening of the gas spring using an Allen wrench.
- 3) Unscrew and remove the locking screw.
- 4) Screw the filling and checking equipment into the fill opening of the gas spring by turning the large knob.
- 5) Turn the small knob inwards. The release pin opens the valve. Caution! Do not turn the release pin inwards too far. Otherwise the valve may be damaged.
- 6) Read the filling pressure on the manometer display.



The permissible filling pressure is printed on the gas spring. If the filling pressure is too low, the nitrogen must be topped up (see chapter 2.4 "Fill with nitrogen" on page 24).

- 7) After checking, turn the small knob to the left as far as it will go. The release pin moves into the retracted position and closes the valve.
- 8) Slowly open the knob on the outlet valve and bleed the fittings.
- 9) Unscrew the fittings from the gas spring by turning the large knob.
- 10) Unscrew the filling adapter.
- 11) Screw the G1/8" locking screw into the fill opening of the gas spring.
 - Tighten using a tightening torque of 15 - 18 Nm (11-13 lb-ft).



The locking screw has a sealing function and must always be fitted.



2.3 Repairs

2.3.1 Required spare parts, tools and tool kits

NOTICE

Damage to the gas pressure spring if other spare parts are used

Only use genuine spare parts from FIBRO GMBH.

All spare parts included in the spare parts kit must always be replaced completely.

Spare parts set for gas spring 2486.22.

The spare parts set comprises:

1	Guide	2	Circlip
3	Dirt ring guard	4	Guide ring
5	DS piston seal	6	DS piston O-ring
7	Flow restrictor	8	Filter screen
9	Valve	10	Locking screw on service port
11	Special oil 35 ml (248.00.50.)	12	O-ring on piston rod
13	Non-return valves	14	Warning tape
15	Sticker		



Fig. 2-2 Spare parts set for gas spring 2486.22.

NOTICE

Damage to the gas pressure spring if other resources and tools are used.

Use the resources and special tools listed below for repairs. The resources and tools can be obtained from FIBRO GMBH.

Equipment and tools

Observe the operating instructions for the filling and checking equipment 2480.00.32.21.

Equipment:

Pos.	Description	Article number
[A]	Filling and checking equipment	2480.00.32.21
[B]	G1/8" filling adapter	2480.00.32.11
[C]	Filling hose	2480.00.31.02
	Cylinder pressure reducer (optional)	2480.00.32.07

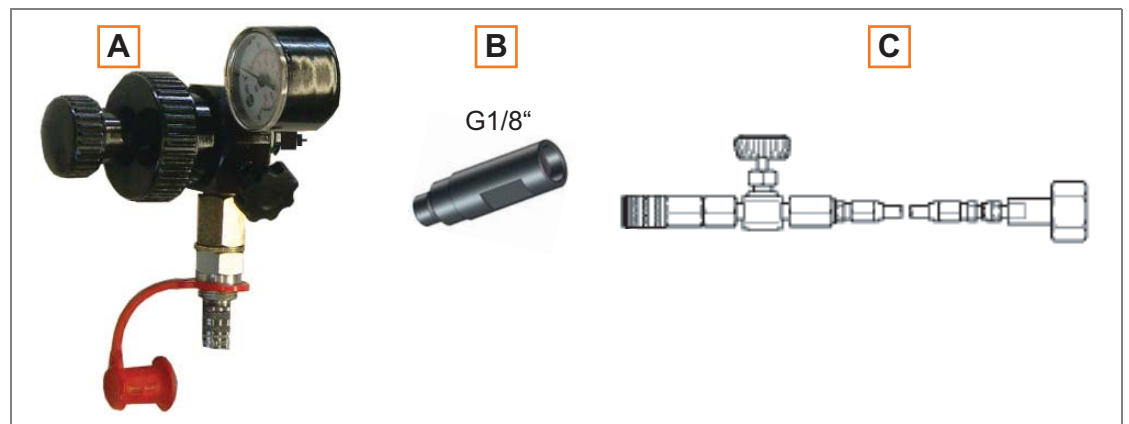

Tools:

Pos.	Description	
[D]	Required parts from tool set (2480.00.50.11)	
(1)	M8 T-lever	(2) M16 T-lever
(3)	Mounting sleeve	(4) Valve tongs
(5)	Circlip tongs	(6) G1/8" valve tool M6 valve tool

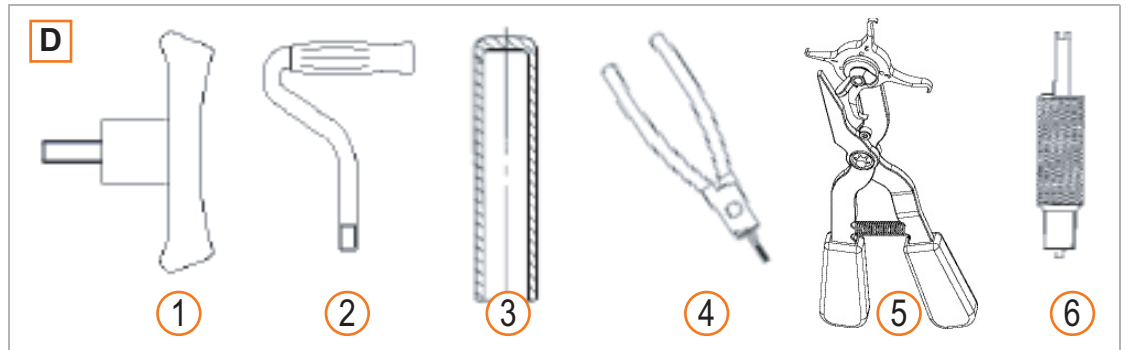

Fig. 2-3 Tool set 2480.00.50.11



To open the locking screw, an Allen wrench is required. To tighten the locking screw, a torque wrench with a hexagon inset socket is required.

- 3 mm wrench size for M6 service port locking screw
- 5 mm wrench size for G1/8" locking screw

2.3.2 Evacuating gas pressure

⚠ WARNING!

High pressure

- ▶ Serious injuries may result if the gas is not fully drained before removing the gas spring.
- ▶ Only trained personnel with good product knowledge are permitted to carry out the activities described.
- ▶ Always wear safety glasses when working on a gas spring.
- ▶ Never bend directly over a valve. Never direct connections towards yourself or other persons.
- ▶ Do not allow any extreme forces to be exerted on the gas spring.
- ▶ When filled, the gas spring is under high internal pressure and must be protected against damage.
- ▶ To maintain the maximum service life of the gas spring, always protect it against dirt, caustic liquids and abrasive dust.
- ▶ When clamping in a vice, always use protective jaws.

NOTICE

The procedure given below for draining the gas must be followed with care.

Evacuation instructions for the safe draining of gas

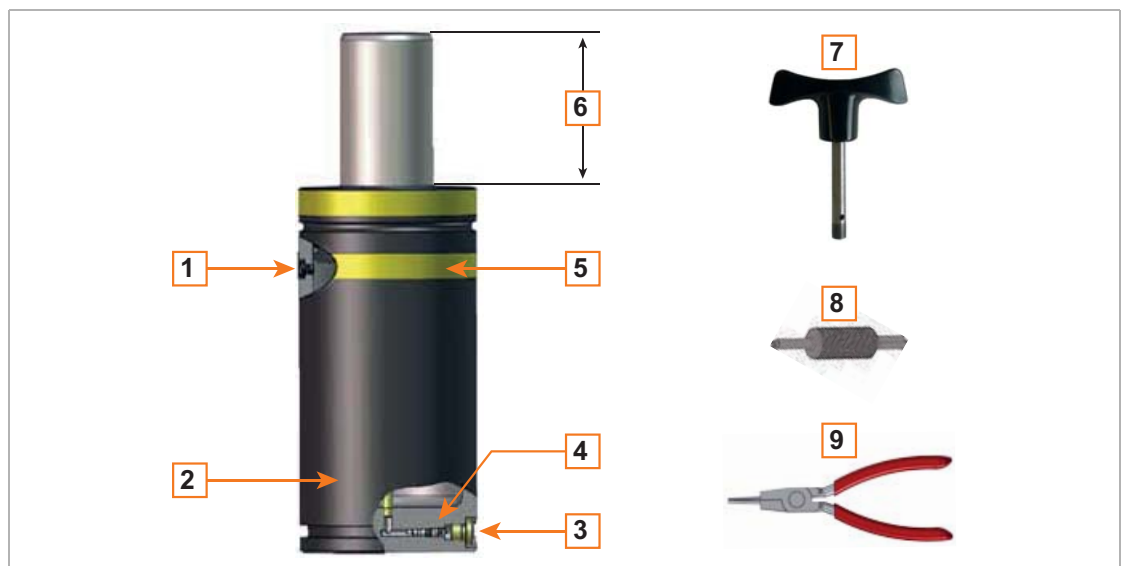

Fig. 2-4 Parts of the DS gas spring / Tools required

- 1 Locking screw on service port
- 2 Cylinder pipe
- 3 Locking screw on fill opening
- 4 Valve
- 5 Warning tape
- 6 Maximum stroke
- 7 M8 T-Lever
- 8 G1/8" Valve tool
- 9 Valve tongs

- 1) Remove warning tape underneath the top C-notch to make the locking screw of the service port visible.

 **WARNING!**

Escaping gas. High pressure.

The locking screw of the service port is under high internal pressure.

- ▶ The locking screw is permitted to be opened by a maximum of one full rotation, and must never be completely removed..
- ▶ Wear safety glasses.
- ▶ Leaking gas can cause eye injuries.

- 2) Use an Allen wrench (3 mm) to turn the locking screw on the service port counter-clockwise by a maximum of one rotation to slightly open the service port and allow the gas to flow out.

NOTICE

After draining the gas from the service port, the piston rod can be extended.

- 3) Leave the service port open.
- 4) Clamp the gas spring in an inclined position (around 30°) in a vice. Piston rod points diagonally downwards.
- 5) Use an Allen key (5 mm) to detach and unscrew the locking screw via the fill opening of the gas spring..

 **WARNING!**

Escaping gas. High pressure.

- ▶ Slowly actuate the valve by screwing in the valve tool.
- ▶ Wear safety glasses.
- ▶ Leaking gas can cause eye injuries.

- 6) Screw in the threaded end of the valve tool into the fill opening until the valve opens and the gas escapes.
- 7) Allow gas to flow out slowly and completely.

NOTICE

The valve is not permitted to be removed until both pressure chambers of the gas spring are completely empty.

- 8) Check the fill level.
 - Screw the T-lever into the piston rod thread.
 - When the piston rod can be moved up and down by hand, the gas spring can be regarded as drained.
- 9) After draining with the other end of the G1/8" valve tool, unscrew the valve out of the thread completely.
- 10) Remove the valve from the fill opening using the valve tongs and dispose of.
- 11) Unscrew and remove the locking screw of the service port.

The gas spring is now prepared for performing maintenance work.



2.3.3 Dismantle gas spring



Position of the components, see chapter 2.1 "Components" on page 7.

- ✓ The gas spring must be evacuated completely (see chapter 2.3.2 "Evacuating gas pressure" on page 14).
Check: Screw the T-lever into the piston rod. When the piston rod can be moved up and down by hand without resistance, there is no more gas in the gas spring.
 - ✓ The oil must be completely drained.
1. Remove the dirt ring guard.
 2. Knock the guide into the pipe using the mounting sleeve and a hammer until the circlip is exposed.
 3. Lever out the circlip using the circlip tool.

CAUTION!

The circlip is tensioned like a spring and may spring out.

- ▶ Wear safety glasses.

4. Clamp the gas spring in a vice.
5. Screw the T-lever into the piston rod and remove the piston rod including the guide and DS piston.



2.



3.



5.

6. Remove the guide from the piston rod and dispose of.
7. Remove the blue guide ring from the piston rod.
8. Remove both piston disc halves from the piston rod.
9. Rotate the piston rod with DS piston.
10. Press the DS piston downwards to expose the circlip halves.

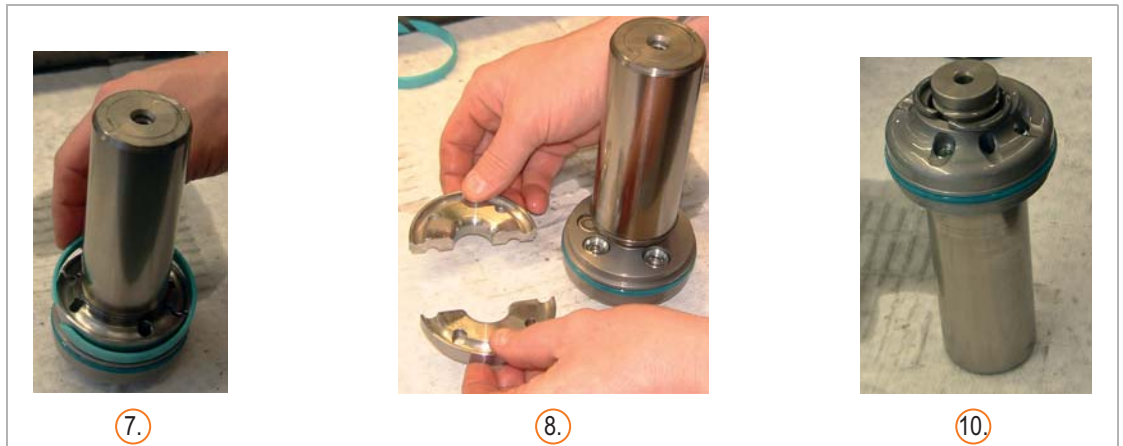

11. Remove the circlip halves.
12. Remove the DS piston from the piston rod to expose the O-ring on the end of the piston rod.

13. Disassembling the DS piston.

- a) Remove the piston seal from the DS piston.
- b) Remove the O-ring from the DS piston. Ensure that the sealing groove in the DS piston is not damaged.
- c) Push the non-return valves out of the guides of the DS piston.
- d) Lever out the filter screen from the flow restrictor.
- e) Unscrew the flow restrictor.

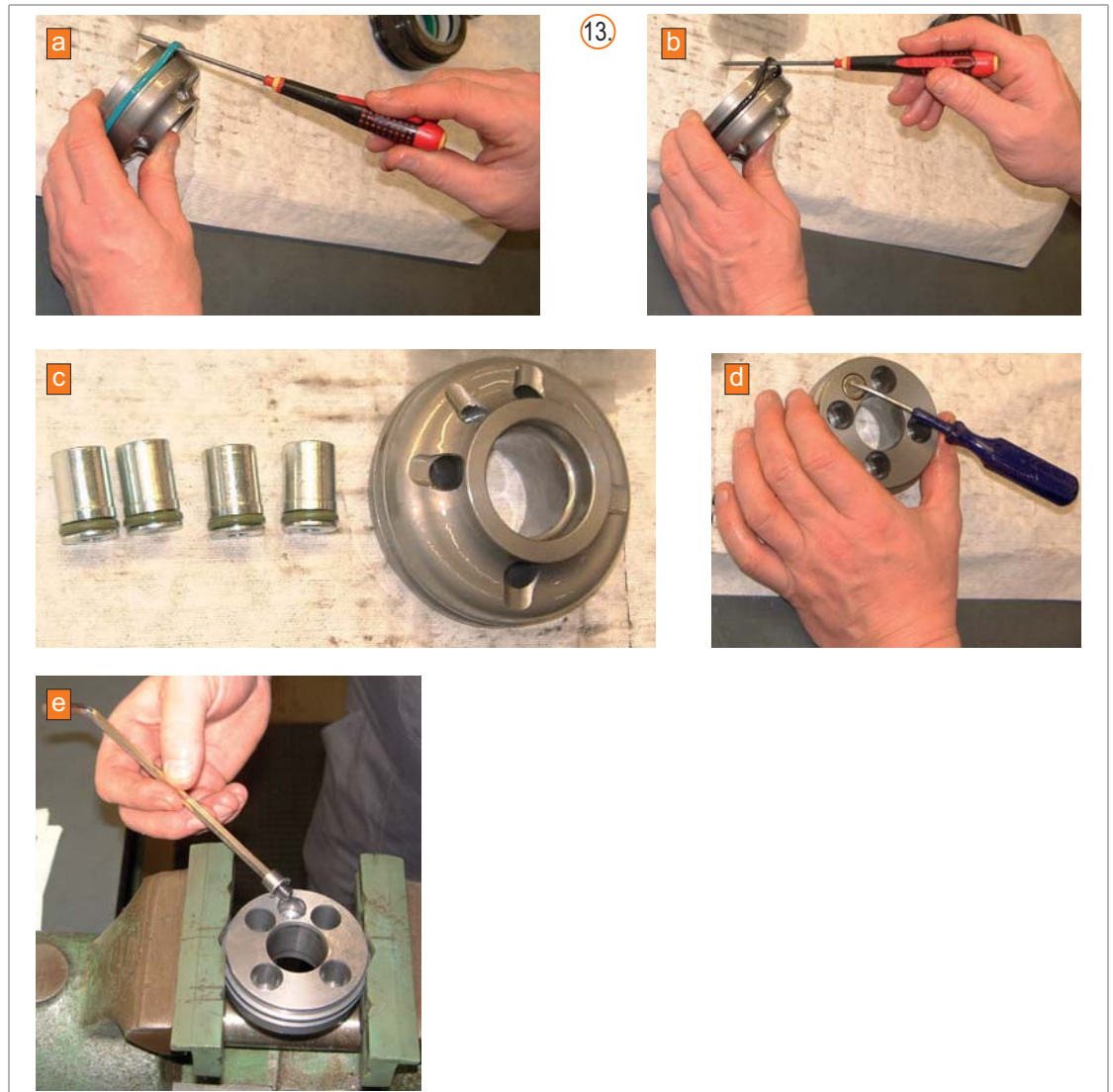

14. Remove the old O-ring from the piston rod.



15. Retain the cylinder pipe, piston rod, DS piston and piston disc halves. Dispose of the remaining components.

2.3.4 Clean and check components

- Clean the cylinder pipe, piston rod, DS piston and piston disc halves.
- Check the interior of the cylinder pipe and piston rod.
 - There must not be any scratches or dents on the interior of the cylinder pipe or piston rod.
 - If these parts are in any way scratched or damaged, they must be replaced.

2.3.5 Assemble gas spring

NOTICE**Jamming, damage to equipment.**

Make sure that the correct piston rod is installed. To check this, place the unmounted piston rod in the cylinder. The upper end of the piston rod and the cylinder have to be in alignment.

1. Unpack the spare parts set and check for completeness. Spare parts in the spare parts set, see chapter 2.3.1 "Required spare parts, tools and tool kits" on page 11.
2. Lubricate the piston rod.
3. Insert the O-ring into the second groove of the piston rod.



4. Pre-assemble the DS piston.
 - a) Fit the O-rings onto the four non-return valves and lubricate.
 - b) Screw the flow restrictor into the piston base.
 - c) Insert the non-return valves with the O-ring into the piston base first.
 - d) Fit the filter screen onto the flow restrictor.



5. Lubricate the O-ring inserted into the second groove of the piston rod.
6. Fit the pre-assembled DS piston onto the piston rod.
7. Insert the circlip halves.



8. Pull the DS piston upwards over the circlip halves.
9. Rotate the piston rod with DS piston by 180°.
10. Pull the O-ring and piston seal onto the DS piston base.
11. Fit the piston disc halves and the guide ring onto the piston rod.
12. Lightly lubricate the seals and guide ring.
13. Lightly lubricate the interior of the new guide.
14. Push the guide over the piston rod.



15. Lightly lubricate the interior of the cylinder pipe and the outside of the guide to avoid damage when inserting the guide ring.
16. Fill the cylinder pipe with the corresponding quantity of special oil.
 - a) DS 3000 -> 20ml
 - b) DS 5000 -> 30ml
 - c) DS 7500 -> 40 ml
17. Insert the piston rod with guide and DS piston into the cylinder pipe.
18. Carefully tap the guide downwards using the mounting sleeve and a rubber hammer until the groove of the circlip is clear.
CAUTION! Do not damage the seals during insertion.
19. Insert the circlip into the groove of the cylinder pipe.
CAUTION! Ensure that the external O-ring (a) is in the correct position.

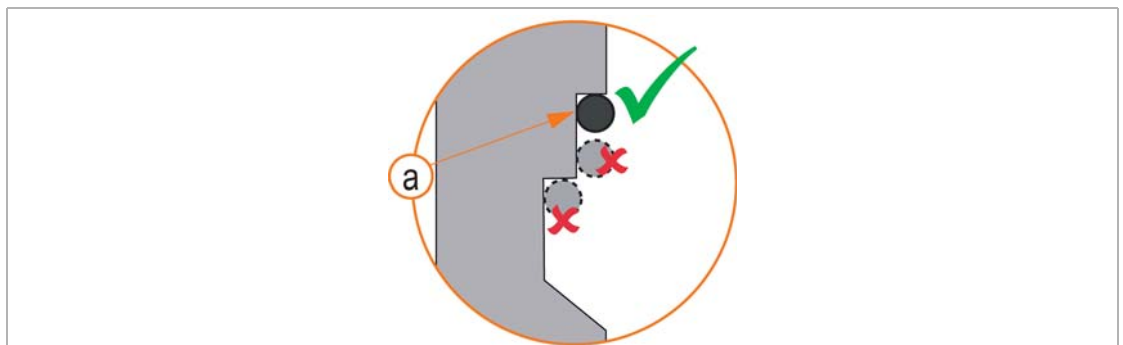

20. Screw the T-lever into the piston rod.
21. Pull out the piston rod and the guide using the T-lever. Pull the T-lever until the guide is flush with the end of the cylinder pipe.
22. Close the service port with the locking screw.
23. Screw the valve with the valve tool into the fill opening.
24. Fill the gas spring with gas (see chapter 2.4 "Fill with nitrogen" on page 24).
25. Mount the dirt ring guard. The dirt ring guard must be in contact with the circlip!
26. Screw in the G1/8" locking screw.
27. Fit a new warning tape over the service port.
28. Remove the old sticker from the cylinder pipe.
29. Affix the supplied sticker onto the cylinder pipe and enter the nominal travel onto the sticker.

2.4 Fill with nitrogen

NOTICE

Damage to the gas pressure spring if other resources are used.

Use the resources listed below for filling. The resources can be obtained from FIBRO GMBH.

Pos.	Description	Article number
[A]	Filling and checking equipment	2480.00.32.21
[B]	G1/8" filling adapter	2480.00.32.11
[C]	Filling hose	2480.00.31.02
	Cylinder pressure reducer (optional)	2480.00.32.07

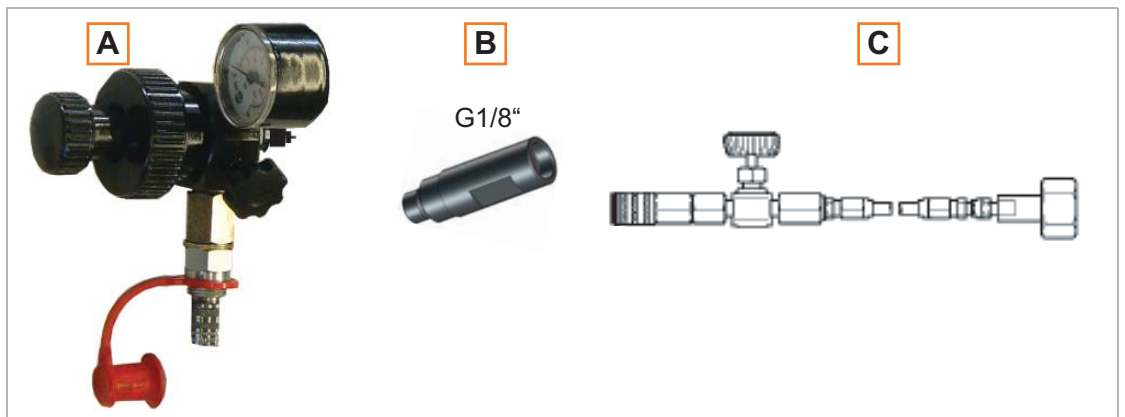

 Observe the operating instructions for the filling and checking equipment 2480.00.32.21.

- 1) Prepare the filling and checking equipment.
 - Turn the small knob (a) to the left as far as it will go. This will move the release pin (b) into the retracted position.
 - Close the outlet valve (c).
 - Screw the filling adapter onto the M6 thread on the fittings. In the process, ensure that the washer seal is located on the M6 thread.

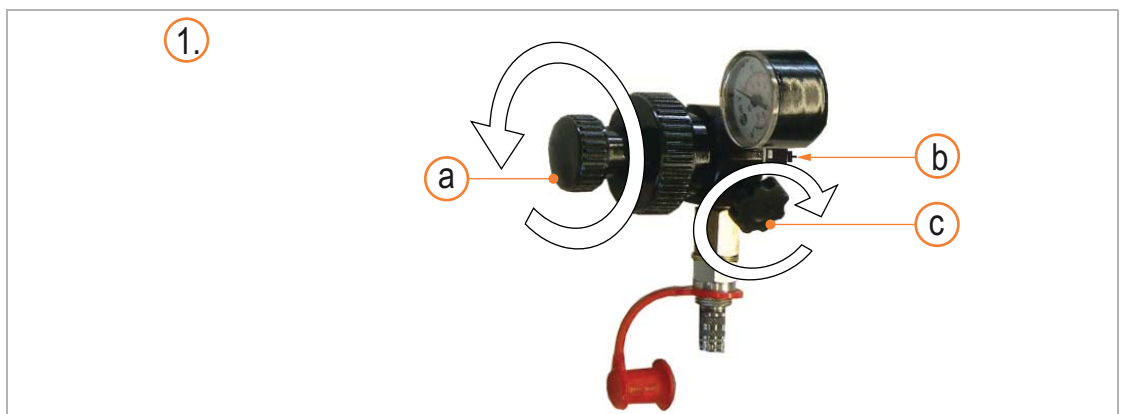

- 2) Screw the filling and checking equipment into the fill opening of the gas spring by turning the large knob.
- 3) Close the locking valve on the filling hose.
- 4) Screw the screw connection on the filling hose onto the nitrogen cylinder.

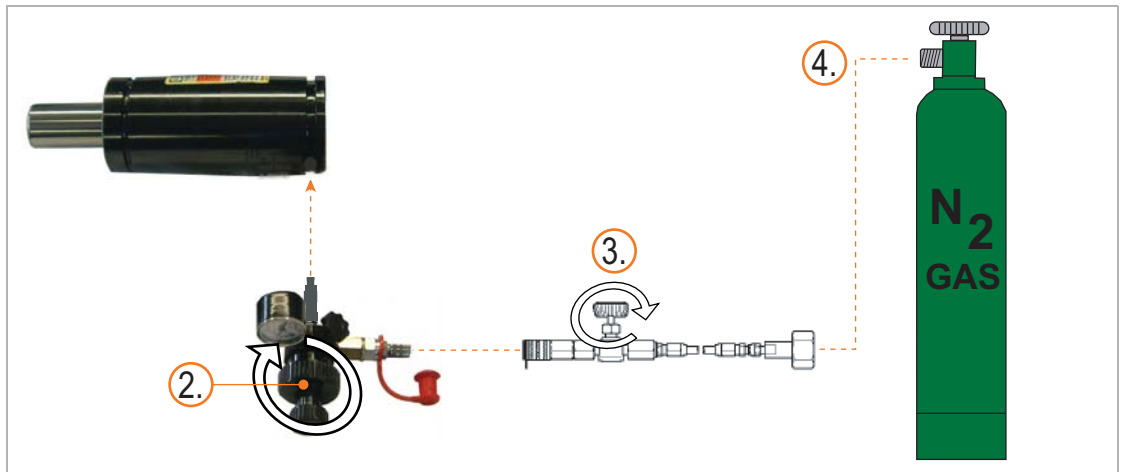

- 5) Fit the quick-fit lock on the filling hose onto the filling and checking equipment.
- 6) Slowly open the nitrogen cylinder on the cylinder valve knob.

NOTICE

Damage to the valve in the gas spring.

- ▶ Slowly open the locking valve on the filling hose
- ▶ Carefully allow the nitrogen to flow in.

- 7) Slowly open the locking valve on the filling hose. The manometer (b) displays the filling pressure.

The permissible filling pressure is printed on the sticker (a).

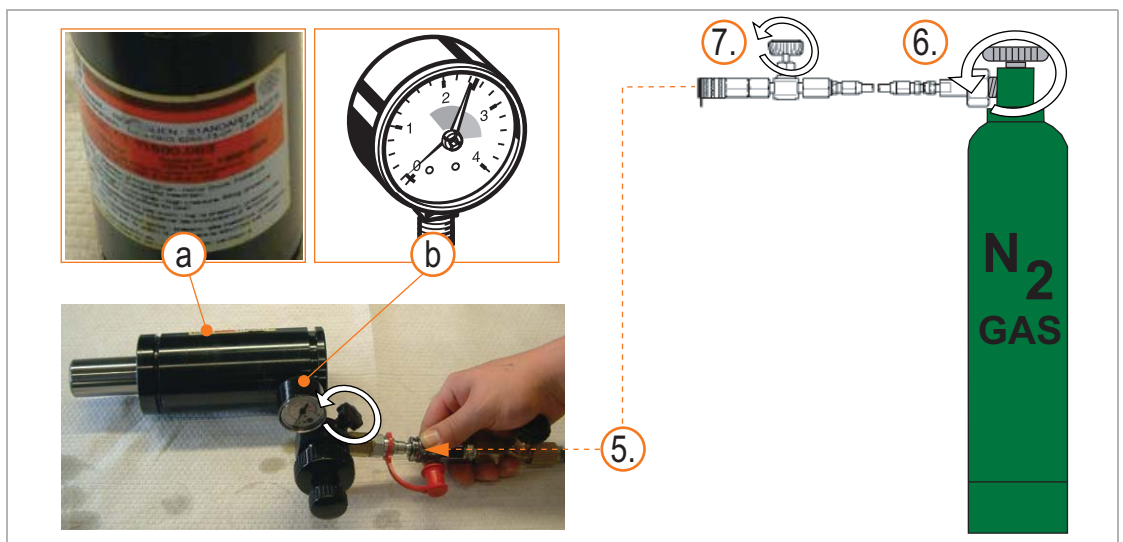

- 8) After reaching the filling pressure, close the locking valve on the filling hose.
- 9) Close the nitrogen cylinder on the cylinder valve knob.
- 10) Re-open the locking valve on the filling hose.
- 11) Open the drain valve on the filling and checking equipment.
 - Pressure and residual nitrogen will escape from the fittings and filling hose.
- 12) Detach the filling hose on the quick-fit lock from the filling and checking equipment
- 13) Detach and unscrew the screw connection on the nitrogen cylinder.
- 14) Unscrew the fittings from the gas spring by turning the large knob.
- 15) Unscrew the filling adapter.
- 16) Clamp the gas spring in a vice.

 **WARNING!**

Escaping nitrogen

Never bend over the gas spring valve.

- ▶ Wear safety glasses.
- ▶ Risk of eye injuries.

- 17) Check that nitrogen is flowing out of the valve on the gas spring.

If nitrogen is escaping, the valve must be replaced (for removal, see chapter 2.3.3 "Dismantle gas spring" see chapter 16).

- 18) Screw the locking screw into the fill opening on the gas spring.
 - Tightening torque for G1/8" locking screw: 15 - 18 Nm (11-13 lb-ft)
 - 5 mm wrench size for G1/8" locking screw

The locking screw has a sealing function and must always be fitted.

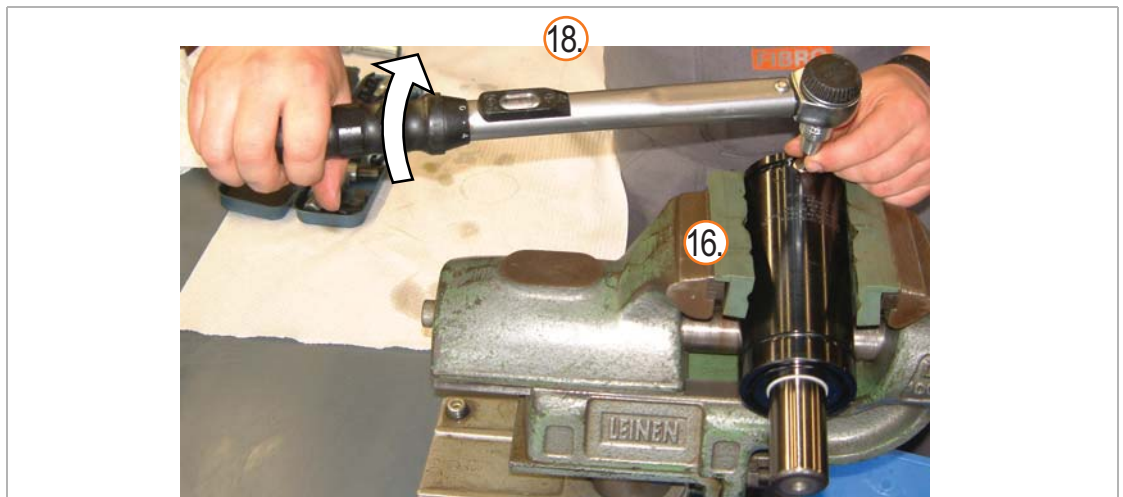

3 INDEXES

3.1 Third-party products

The product contains no components from third-party companies.

3.2 Glossary

Term	Explanation
Instructions	General designation for this document.
Tightening torque	Force with which a screw connection is tightened using a tool.
Product	General designation for the product described in these instructions.
Residual risk	Danger that could not be completely eliminated despite special design measures.
Safety notice	Notice in the instructions and manuals with reference to possible physical injuries.
Safety information	Information relating to the safe handling of a component.

3.3 Index of figures

Fig. 2-1	Components of the gas springs	7
Fig. 2-2	Spare parts set for gas spring 2486.22.	11
Fig. 2-3	Tool set 2480.00.50.11	13
Fig. 2-4	Parts of the DS gas spring / Tools required	14

3.4 Index

A

Allen wrench 13 15

C

Circlip 7 11 16 22 23

Circlip halves 7 17 17 21

Circlip tongs 13

Circlip tool 16

C-notch 15

Components

Gas spring 7

Copyright 2

Cylinder pipe 14 19 19 22

Cylinder pressure reducer 12 24

D

Dangers

possible 5

Dirt ring guard 7 11 16 23

Documents, applicable 6

DS piston 7 16 17 19 19 21 22

O-ring 7

seal 11 22

DS piston

seal 7

F

Fill opening 15 23

Filling and checking equipment 12 24 24

Filling hose 12 24 25

Filling pressure 26

permissible 6

Filter screen 7 11 18 21

Flow restrictor 7 11 18 21

G

G1/8" filling adapter 12 24

Groove

Circlip 22

Cylinder pipe 22

Guide 7 11 16 22

Guide ring 7 22 22

I

Injuries

preventing 5

L

Locking screw 15

fill opening 14

Fill opening 7 26

G1/8" 13

M6 13

service port 14

Service port 7 11 23

Locking valve 25 26

M

Mounting sleeve 13 16 22

N

Non-return valve 7

Non-return valves 11 18 21

O

O-ring

DS piston 18 22

Non-return valves 21

piston rod 20

Piston rod 11 17

P

Piston base 21

Piston disc

separated 7

Piston disc halves 17 19 19 22

Piston rod 7 15 15 16 17 19 19 20 22

Piston seal

DS piston 18

Pressure chambers

both 15

R

Rubber hammer 22

S

Safety notices 5

Sealing groove 18

Sealing ring 7

Service port 15

Signal bar 5

Signal word 5

Spare parts set 11 20

Special oil 11 22

Sticker 11

Stroke

maximum 14

T

T-lever 13 15 16 23

T-Lever

M8 14

Tool set 13

Torque wrench 13

V

Valve 7 11 14 23 26

Valve tongs 13 14 15

Valve tool 15 23

G1/8" 13

M6 13

Valve tool G1/8" 15

W

Warning tape 7 11 14 15 23

FIBRO GMBH

Business Area Standard Parts
August-Läpple-Weg
74855 Hassmersheim
Germany
T +49 06266 73-0
info@fibro.de

THE LÄPPLE GROUP

LÄPPLE AUTOMOTIVE
FIBRO
FIBRO LÄPPLE TECHNOLOGY
LÄPPLE AUS- UND WEITERBILDUNG

LOCATIONS

FIBRO France Sarl

Département Eléments normalisés
26 Avenue de l'Europe
67300 Schiltigheim
France
T +33 3 90 20 40 40
info@fibro.fr

FIBRO INDIA

PRECISION PRODUCTS PVT. LTD.
Business Area Standard Parts
Plot No: A-55, Phase II, Chakan Midc,
Taluka Khed, Pune - 410 501
India
T +91 21 35 33 88 00
info@fibro-india.com

FIBRO ASIA PTE. LTD.

Business Area Standard Parts
9 Changi South Street 3, #07-04
Singapore 486361
Singapore
T +65 65 43 99 63
info@fibro-asia.com

FIBRO INC.

Business Area Standard Parts
39 Harrison Avenue
Rockford, IL 61104
USA
T +1 815 2 29 13 00
info@fibroinc.com

FIBRO (SHANGHAI)

PRECISION PRODUCTS CO., LTD.
Business Area Standard Parts
1st Floor, Building 3, No. 253, Ai Du Road
Pilot Free Trade Zone, Shanghai 200131
China
T +86 21 60 83 15 96
info@fibro.cn

FIBRO KOREA CO., LTD

203-603, Bucheon Technopark
Ssangyong 3
397, Seokcheon-ro, Ojeong-gu,
Bucheon-si, Gyeonggi-do
Korea
T +82 32 624 0630
fibro_korea@fibro.kr

FIBRO POLSKA SP. Z O. O.

ALEJA ARMII KRAJOWEJ 220
PAWILON AG PIĘTRO 3/ POKÓJ 306
43-316 BIELSKO-BIAŁA
POLSKA
T +(48) 6980 57720