

COMPOSITE PLATE SYSTEM



COMPOSITE PLATE SYSTEM GENERAL

The connection of gas compression springs in one or more systems offers the user the option to monitor the gas pressure of the gas compression springs outside the tool, adjusting them as required, filling them and discharging them.

The advantages of the composite system lie in the ease of maintenance, safety and quality improvement of the gas pressure spring application in the tool.

Composite plate system

Composite plate systems are advantageously used where, due to minimal space conditions, there is no option to connect the gas compression springs via tubing in the assembly.

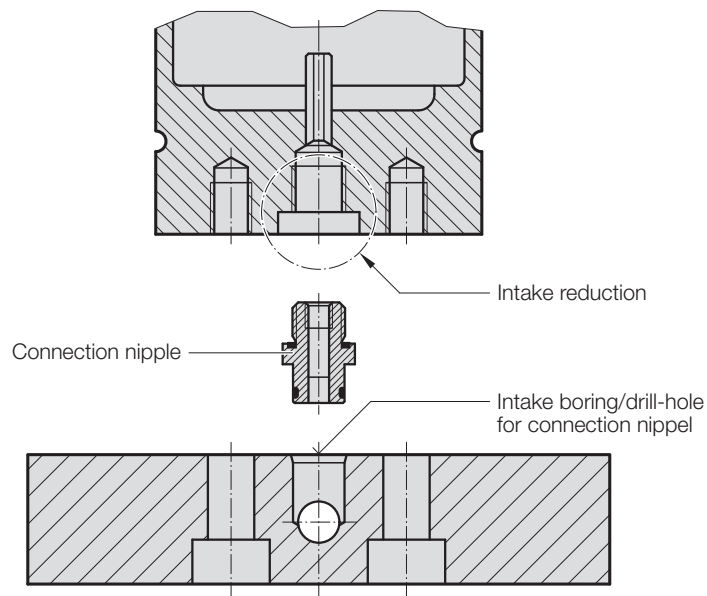

FIBRO – Composite plate system

- can be used as an alternative to gas pressure springs in a hose assembly
- offers high ease of maintenance with long maintenance intervals
- no hose connections necessary between the gas pressure springs
- Leak-tightness guarantee even with frequent installation or removal of the system
- no special tools required for set-up and disassembly
- is approved under Pressure Equipment Directive 2014/68/EU and assembled ready for installation

Further information:

- Customer-specific design of the FIBRO composite panel by qualified personnel
- individual machining according to customer specifications
- Gas compression springs available from stock
- Control fittings with hose lines or optionally mounted directly on composite plate

Ideally, the bottom-side threaded bores are used for fastening the gas springs. Sealing is implemented either via a connecting nipple or a flat gasket in the spring base as well as with a receiving bore in the composite plate.

COMPOSITE PLATE SYSTEM DESIGN INSTRUCTIONS



The following figures show the most important general design instructions and minimum dimensions to be observed.

Your FIBRO specialist staff will provide you with further information.

Blind bore holes are to be avoided as otherwise impurities can settle or chip-free cleaning after plate production is made more difficult.

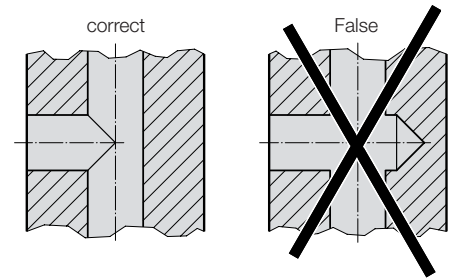

The minimum distance to the deep-hole bore must not be less than 5 mm.

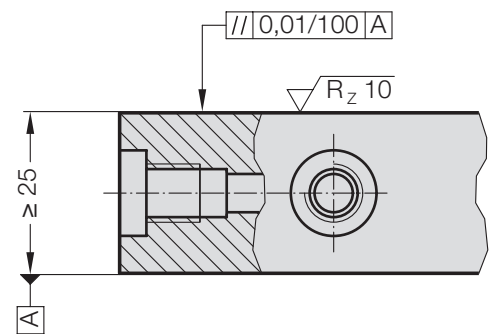
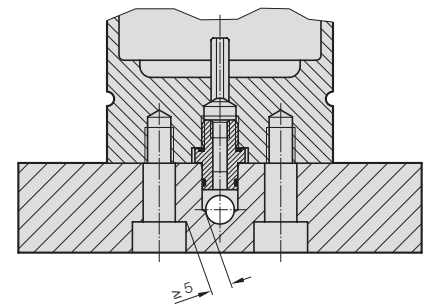
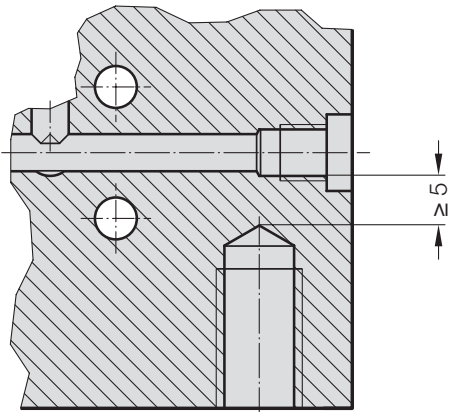

General design instructions

During manufacturing, attention must be paid to the parallelism of the plate. It is therefore machine-ground to achieve the corresponding surface roughness.

To loosen burr and dirt particles, the deep-hole bores must be brushed out. Unremoved dirt particles can migrate to the sealing surface of the gas springs and destroy it over the medium or long term.

Safety information

Before disassembly, it is essential to release the pressure completely at the designated vent valve on the control fitting. The reworking of the gas pressure springs and control fittings may only be carried out by FIBRO.

COMPOSITE PLATE SYSTEM **EXAMPLE**

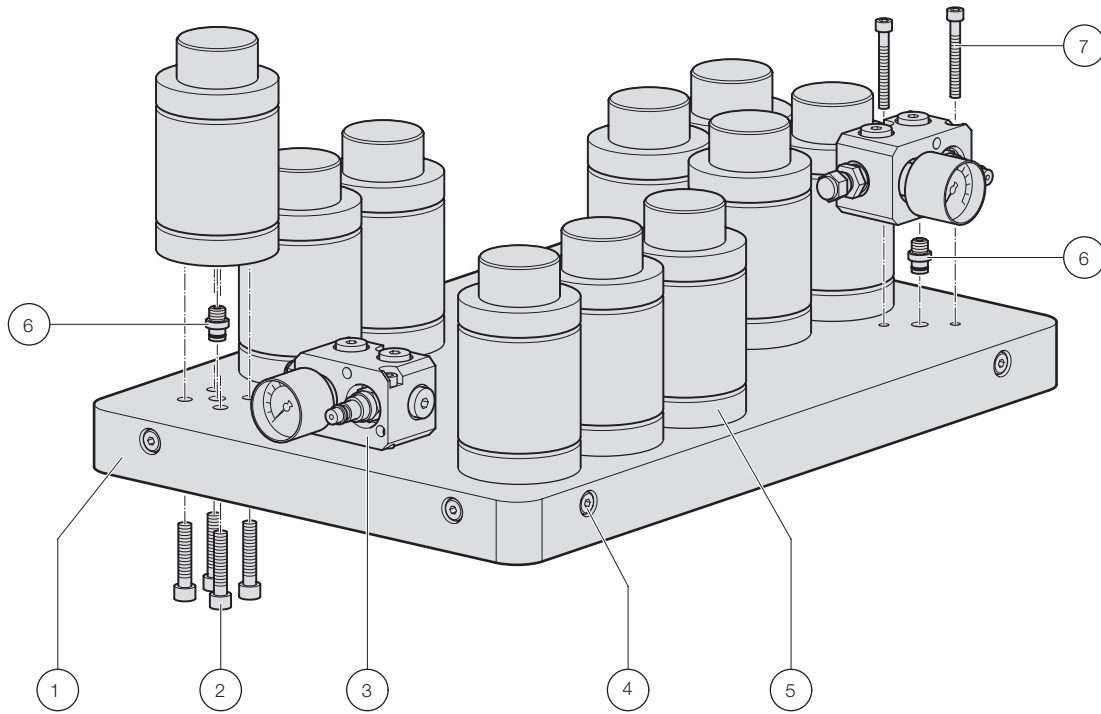

Item	Description	Order No.
1	Composite plate	2494.xxxxxx.xxxx.100
2	Socket head cap screw	2192.12.08.040
3	Control fitting	2480.94.00.31.01.0x
4	Pipe plug G1/8	248.00.43.2
5	Compact gas spring	2490.94.14.04700.025
6	Connecting nipple	mounted in spring base/control fitting
7	Socket head cap screw	2192.12.06.050

COMPOSITE PLATE SYSTEM

2480.93.22. .1 – GAS SPRING, STANDARD, FOR COMPOSITE PANEL, FLAT SEAL

Connection geometry

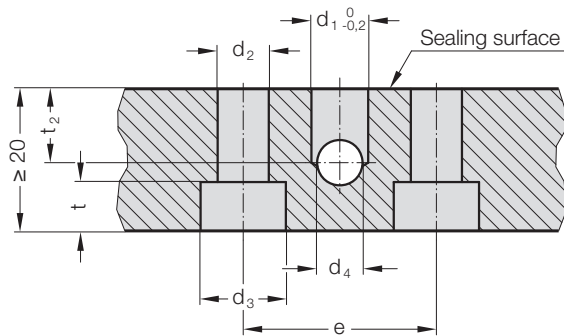

Gas springs

Order No. for composite plate connection

Order No. for composite plate connection	e	d ₁	d ₂	d ₃	d ₄	t	t ₂	n*
2480.93.22.00200. .1	18	5	6,4	11	6	7	6	2

* Number of gas spring mounting holes

COMPOSITE PLATE SYSTEM 2480.93.22. .1 – GAS SPRING, STANDARD, FOR COMPOSITE PANEL, FLAT SEAL

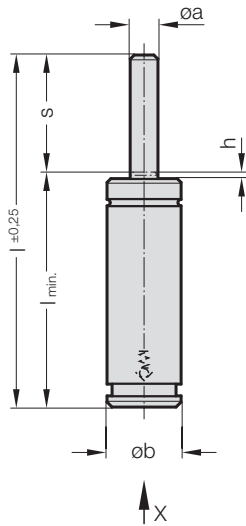

View X - Gas spring

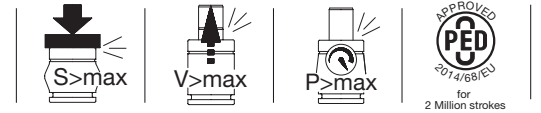
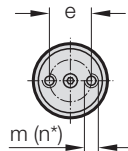

View/Design
gas spring with flat seal

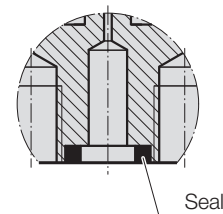

Technical information

Pressure medium:	Nitrogen	N_2
Max. filling pressure:		150 bar
Min. filling pressure:		50 bar
Working temperature:		0°C up to +80°C
Temperature related force increase:		$\pm 0,3\%/^{\circ}C$
Max. recommended extensions per minute:		approx. 15 up to 40 (at 20°C)
Max. piston speed:		1,6 m/s

Ordering Code (example): 2480.93.22.00200.013.1

Spring force in daN at 150 bar/+20°C

Order No.	Initial spring force	Final force ¹⁾	$\varnothing a$	$\varnothing b$	h	m	n^*	e	
2480.93.22.00200. .1	150	230	12	32	-0,1	1	M6 x 11 deep	2	18

¹⁾ at full stroke (s) / * Number of gas spring mounting holes

Order No.	Stroke (s)	010	013	016	025	038	050	063	080	100	125
	s	10	12,7	16	25	38,1	50	63,5	80	100	125
2480.93.22.00200. .1	l	70	75,4	82	100	126,2	150	177	210	250	300
	l_{min}	60	62,7	66	75	88,1	100	113,5	130	150	175

COMPOSITE PLATE SYSTEM

2480.93.1□. – GAS SPRING, STANDARD, FOR COMPOSITE PANEL, FLAT SEAL

Connection geometry

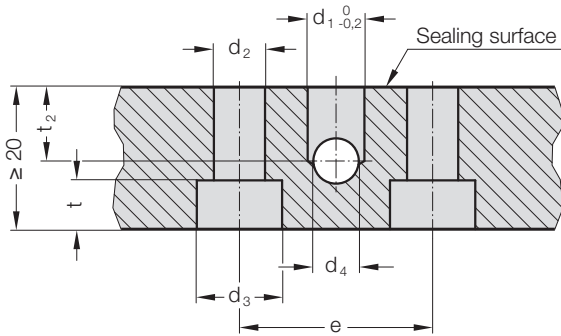

Gas springs

Order No. for composite plate connection

Order No. for composite plate connection	e	d ₁	d ₂	d ₃	d ₄	t	t ₂	n*
2480.93.13.00250.	18	5	6,4	11	6	7	6	2
2480.93.13.00500.	20	5	8,4	15	6	9	6	2
2480.93.13.00750.	20	5	8,4	15	6	9	6	2
2480.93.12.01500.	40	5	8,4	15	8	9	10	4
2480.93.13.03000.	60	5	8,4	15	8	9	10	4
2480.93.13.05000.	80	8	10,5	18	8	11	10	4
2480.93.13.07500.	100	8	10,5	18	8	11	10	4
2480.93.12.10000.	120	8	13	20	8	13	10	4

* Number of gas spring mounting holes

COMPOSITE PLATE SYSTEM

2480.93.1□. – GAS SPRING, STANDARD, FOR COMPOSITE PANEL, FLAT SEAL

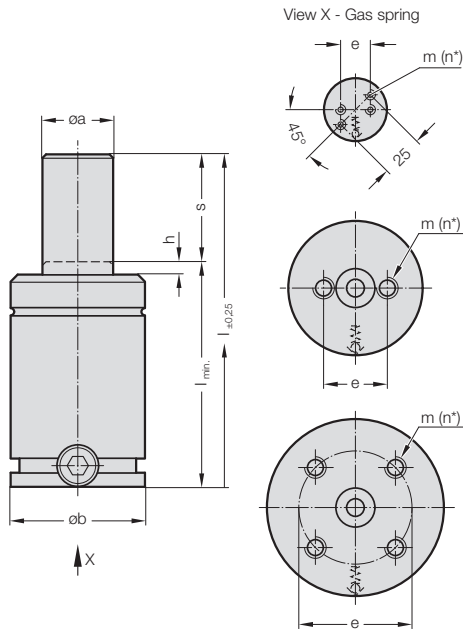

View/Design gas spring with flat seal

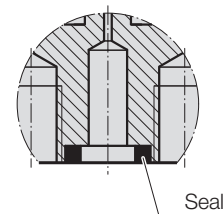

Technical information

Pressure medium:	Nitrogen	N ₂
Max. filling pressure:	150 bar	
Min. filling pressure:	50 bar	
Working temperature:	0°C up to +80°C	
Temperature related force increase:	± 0,3%/°C	
Max. recommended extensions per minute:	approx. 15 up to 40 (at 20°C)	
Max. piston speed:	1,6 m/s	

Ordering Code (example): 2480.93.13.00500.013

Spring force in daN at 150 bar/+20°C

Order No.	Initial spring force	Final force ¹⁾	oa	ob	h	m	n*	e	
2480.93.13.00250.	250	265 - 350	15	38	-0,2	2	M6 x 8 deep	2	18
2480.93.13.00500.	470	600 - 670	20	45,2	±0,1	2	M8 x 12,5 deep	2	20
2480.93.13.00750.	750	1200 - 1210	25	50,2	±0,1	3	M8 x 12,5 deep	2	20
2480.93.12.01500.	1500	2300	36	75,2	±0,1	3	M8 x 12,5 deep	4	40
2480.93.13.03000.	3000	4200 - 4800	50	95,2	±0,1	3	M8 x 12,5 deep	4	60
2480.93.13.05000.	5000	7100 - 8400	65	120,2	±0,1	3	M10 x 16 deep	4	80
2480.93.13.07500.	7500	10500 - 12400	80	150,2	±0,1	3	M10 x 16 deep	4	100
2480.93.12.10000.	10600	13800 - 16000	95	195	-0,2	3	M12 x 16 deep	4	120

¹⁾ at full stroke (s) / * Number of gas spring mounting holes

Order No. Stroke (s)	010	013	016	019	025	038	050	063	075	080	088	100	113	125	138	150	160	175	200	225	250	275	300	
s	10	12,7	16	19	25	38,1	50	63,5	75	80	87,5	100	112,5	125	137,5	150	160	175	200	225	250	275	300	
2480.93.13.00250.	l	70	75,4	82	88	100	126,2	150	177	-	210	-	250	-	125	-	-	-	-	-	-	-	-	-
	l _{min.}	60	62,7	66	69	75	88,1	100	113,5	-	130	-	150	-	175	-	-	-	-	-	-	-	-	-
2480.93.13.00500.	l	105	110,4	-	-	135	161,2	185	212	-	245	-	285	-	335	-	-	405	-	-	-	-	-	-
	l _{min.}	95	97,7	-	-	110	123,1	135	148,5	-	165	-	185	-	210	-	-	245	-	-	-	-	-	-
2480.93.13.00750.	l	120,4	-	-	145	171,2	195	222	245	255	270	295	320	345	370	395	415	445	495	545	595	645	695	
	l _{min.}	107,7	-	-	120	133,1	145	158,5	170	175	182,5	195	207,5	220	232,5	245	255	270	295	320	345	370	395	
2480.93.12.01500.	l	-	135	-	-	160	186,2	210	237	260	270	285	310	335	360	385	410	430	460	510	560	610	660	710
	l _{min.}	-	122,3	-	-	135	148,1	160	173,5	185	190	197,5	210	222,5	235	247,5	260	270	285	310	335	360	385	410
2480.93.13.03000.	l	-	145	-	-	170	196,2	220	247	270	280	295	320	345	370	395	420	440	470	520	570	620	670	720
	l _{min.}	-	132,3	-	-	145	158,1	170	183,5	195	200	207,5	220	232,5	245	257,5	270	280	295	320	345	370	395	420
2480.93.13.05000.	l	-	-	-	-	190	216,2	240	267	290	300	315	340	365	390	415	440	460	490	540	590	640	690	740
	l _{min.}	-	-	-	-	165	178,1	190	203,5	215	220	227,5	240	252,5	265	277,5	290	300	315	340	365	390	415	440
2480.93.13.07500.	l	-	-	-	-	205	231,2	255	282	305	315	330	355	380	405	430	455	475	505	555	605	655	705	755
	l _{min.}	-	-	-	-	180	193,1	205	218,5	230	235	242,5	255	267,5	280	292,5	305	315	330	355	380	405	430	455
2480.93.12.10000.	l	-	-	-	-	210	236,2	260	287	-	320	-	360	-	410	-	-	480	-	560	-	660	-	760
	l _{min.}	-	-	-	-	185	198,1	210	223,5	-	240	-	260	-	285	-	-	320	-	360	-	410	-	460

COMPOSITE PLATE SYSTEM

2480.94.1□. – GAS SPRING, STANDARD, FOR COMPOSITE PANEL, WITH CONNECTING NIPPLE

Connection geometry

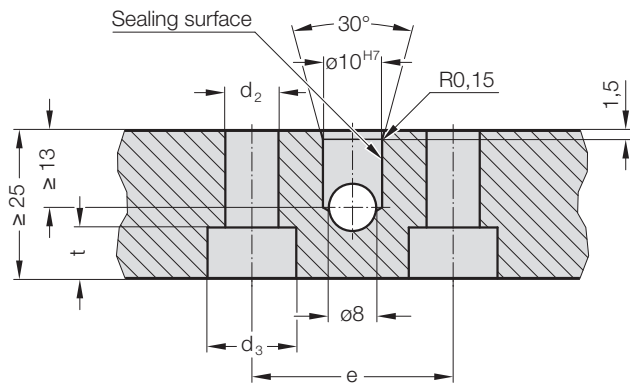

Gas springs

Order No. for composite plate connection

Order No. for composite plate connection	e	d ₂	d ₃	t	n*
2480.94.12.01500.	40	8,4	15	9	4
2480.94.13.03000.	60	8,4	15	9	4
2480.94.13.05000.	80	10,5	18	11	4
2480.94.13.05000.	100	10,5	18	11	4
2480.94.12.10000.	120	13	20	13	4

* Number of gas spring mounting holes



COMPOSITE PLATE SYSTEM 2480.94.1□. – GAS SPRING, STANDARD, FOR COMPOSITE PANEL, WITH CONNECTING NIPPLE

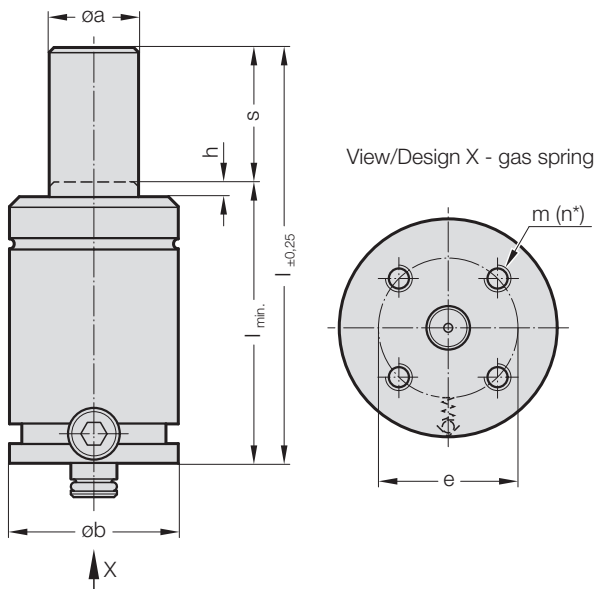

Technical information

Pressure medium:	Nitrogen	N ₂
Max. filling pressure:	150 bar	
Min. filling pressure:	50 bar	
Working temperature:	0°C up to +80°C	
Temperature related force increase:	± 0,3%/°C	
Max. recommended extensions per minute:	approx. 15 up to 40 (at 20°C)	
Max. piston speed:	1,6 m/s	

Ordering Code (example): 2480.94.12.01500.013

Spring force in daN at 150 bar/+20°C

Order No.	Initial spring force	Final force ¹⁾	øa	øb	h	m	n*	e
2480.94.12.01500.	1500	2300	36	75,2 ±0,1	3	M8 x 12,5 deep	4	40
2480.94.13.03000.	3000	4200 - 4800	50	95,2 ±0,1	3	M8 x 12,5 deep	4	60
2480.94.13.05000.	5000	7100 - 8400	65	120,2 ±0,1	3	M10 x 16 deep	4	80
2480.94.13.05000.	7500	10500 - 12400	80	150,2 ±0,1	3	M10 x 16 deep	4	100
2480.94.12.10000.	10600	13800 - 16000	95	195 -0,2	3	M12 x 16 deep	4	120

¹⁾ at full stroke (s) / * Number of gas spring mounting holes

Order No. Stroke (s)	010	013	016	019	025	038	050	063	075	080	088	100	113	125	138	150	160	175	200	225	250	275	300	
s	10	12,7	16	19	25	38,1	50	63,5	75	80	87,5	100	112,5	125	137,5	150	160	175	200	225	250	275	300	
2480.94.12.01500.	l	-	135	-	-	160	186,2	210	237	260	270	285	310	335	360	385	410	430	460	510	560	610	660	710
	l _{min.}	-	122,3	-	-	135	148,1	160	173,5	185	190	197,5	210	222,5	235	247,5	260	270	285	310	335	360	385	410
2480.94.13.03000.	l	-	145	-	-	170	196,2	220	247	270	280	295	320	345	370	395	420	440	470	520	570	620	670	720
	l _{min.}	-	132,3	-	-	145	158,1	170	183,5	195	200	207,5	220	232,5	245	257,5	270	280	295	320	345	370	395	420
2480.94.13.05000.	l	-	-	-	-	190	216,2	240	267	290	300	315	340	365	390	415	440	460	490	540	590	640	690	740
	l _{min.}	-	-	-	-	165	178,1	190	203,5	215	220	227,5	240	252,5	265	277,5	290	300	315	340	365	390	415	440
2480.94.13.05000.	l	-	-	-	-	205	231,2	255	282	305	315	330	355	380	405	430	455	475	505	555	605	655	705	755
	l _{min.}	-	-	-	-	180	193,1	205	218,5	230	235	242,5	255	267,5	280	292,5	305	315	330	355	380	405	430	455
2480.94.12.10000.	l	-	-	-	-	210	236,2	260	287	-	320	-	360	-	410	-	-	480	-	560	-	660	-	760
	l _{min.}	-	-	-	-	185	198,1	210	223,5	-	240	-	260	-	285	-	-	320	-	360	-	410	-	460

COMPOSITE PLATE SYSTEM

2487.93.12. – GAS SPRING POWERLINE, FOR COMPOSITE PANEL, FLAT SEAL

Connection geometry

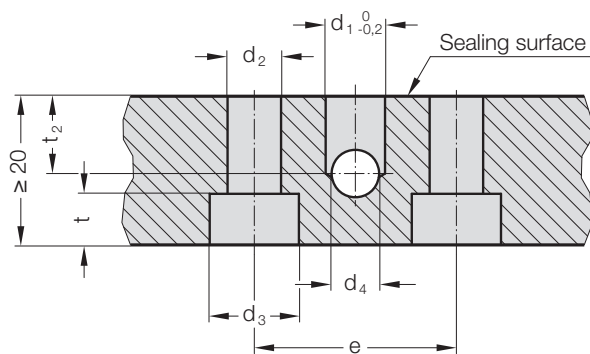

Gas springs Order No. for composite plate connection

Order No. for composite plate connection	e	d ₁	d ₂	d ₃	d ₄	t	t ₂	n*
2487.93.12.00350.	20	5	6,4	11	6	6,8	6	2
2487.93.12.00500.	20	5	6,4	11	6	6,8	6	2
2487.93.12.00750. .1	20	5	6,4	11	6	6,8	6	2
2487.93.12.01000. .1	20	5	8,4	15	6	9	6	2
2487.93.12.01500.	20	5	8,4	15	6	9	6	2
2487.93.12.02400.	40	5	8,4	15	8	9	10	4
2487.93.12.04200.	60	8	8,4	15	8	9	10	4
2487.93.12.06600.	80	8	10,5	18	8	11	10	4
2487.93.12.09500.	100	8	10,5	18	8	11	10	4
2487.93.12.20000.	120	8	13	20	8	13	10	4

* Number of gas spring mounting holes

COMPOSITE PLATE SYSTEM

2487.93.12. – GAS SPRING POWERLINE, FOR COMPOSITE PANEL, FLAT SEAL

View/Design X - gas spring
2487.93.12.00350. - .01000. .1

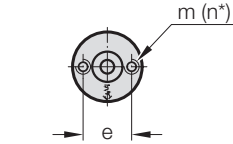
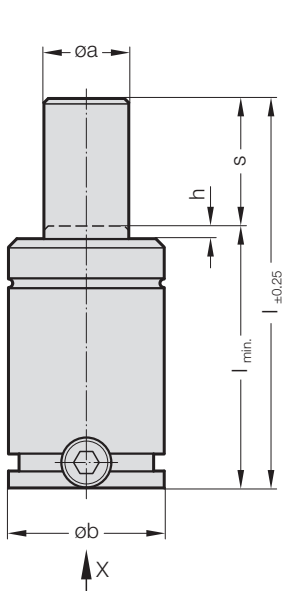

2487.93.12.01500.

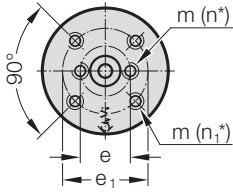

2487.93.12.02400. - .20000.

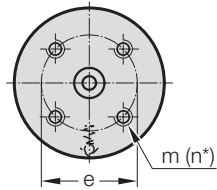

View/Design
gas spring with flat seal

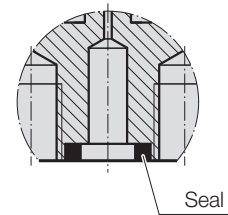

Technical information

Pressure medium: Nitrogen	N ₂
Max. filling pressure:	180 bar
Min. filling pressure:	25 bar
Working temperature:	0°C up to +80°C
Temperature related force increase:	± 0,3%/°C
Max. recommended extensions per minute:	approx. 20 up to 100 (at 20°C)
Max. piston speed:	1,6 m/s

Ordering Code (example): 2487.93.12.00350.013

Spring force in daN at 150 bar/+20°C

Order No.	Initial spring force	Final force ¹⁾	oa	ob		h	m	n*	n ₁	e	e ₁
2487.93.12.00350.	350	520 - 590	16	32	-0,2	2	M6 x 6 deep	2	-	20	-
2487.93.12.00500.	470	710 - 740	20	38	-0,2	2	M6 x 8 deep	2	-	20	-
2487.93.12.00750. .1	750	1180 - 1210	25	45,2	±0,1	2	M8 x 6 deep	2	-	20	-
2487.93.12.01000. .1	920	1380 - 1480	28	50,2	±0,1	3	M8 x 6 deep	2	-	20	-
2487.93.12.01500.	1500	2380 - 2430	36	63,2	±0,1	3	M8 x 6 deep	2	4	20	40
2487.93.12.02400.	2400	3830 - 3930	45	75,2	±0,1	3	M8 x 6 deep	4	-	40	-
2487.93.12.04200.	4200	6170 - 6960	60	95,2	±0,1	3	M8 x 12 deep	4	-	60	-
2487.93.12.06600.	6630	9100 - 10650	75	120,2	±0,1	3	M10 x 12 deep	4	-	80	-
2487.93.12.09500.	9500	1350 - 15200	90	150,2	±0,1	3	M10 x 13 deep	4	-	100	-
2487.93.12.20000.	20000	25900 - 33000	130	195	-0,2	3	M12 x 16 deep	4	-	120	-

¹⁾ at full stroke (s) / * Number of gas spring mounting holes

Order No. Stroke (s)	010	013	016	019	025	032	038	050	063	075	080	100	125
s	10	13	16	19	25	32	38	50	63	75	80	100	125
2487.93.12.00350.	l	50	56	62	68	80	94	106	130	156	180	190	230
	l _{min.}	40	43	46	49	55	62	68	80	93	105	110	130
2487.93.12.00500.	l	50	56	62	68	80	94	106	130	156	180	190	230
	l _{min.}	40	43	46	49	55	62	68	80	93	105	110	130
2487.93.12.00750. .1	l	52	58	64	70	82	96	108	132	158	182	192	232
	l _{min.}	42	45	48	51	57	64	70	82	95	107	112	132
2487.93.12.01000. .1	l	-	64	70	76	88	102	114	138	164	188	198	238
	l _{min.}	-	51	54	57	63	70	76	88	101	113	118	138
2487.93.12.01500.	l	-	70	76	82	94	108	120	144	170	194	204	244
	l _{min.}	-	57	60	63	69	76	82	94	107	119	124	144
2487.93.12.02400.	l	-	-	77	83	95	109	121	145	171	195	205	245
		-	-	61	64	70	77	83	95	108	120	125	145
2487.93.12.04200.	l	-	-	90	96	108	122	134	158	184	208	218	258
	l _{min.}	-	-	74	77	83	90	96	108	121	133	138	158
2487.93.12.06600.	l	-	-	100	106	118	132	144	168	194	218	228	268
	l _{min.}	-	-	84	87	93	100	106	118	131	143	148	168
2487.93.12.09500.	l	-	-	-	116	128	142	-	178	204	228	238	278
	l _{min.}	-	-	-	97	103	110	116	128	141	153	158	178
2487.93.12.20000.	l	-	-	-	148	160	174	186	210	236	260	270	310
	l _{min.}	-	-	-	129	135	142	148	160	173	185	190	210

COMPOSITE PLATE SYSTEM

2487.94.12. – GAS SPRING POWERLINE, FOR COMPOSITE PANEL, WITH CONNECTING NIPPLE

Connection geometry

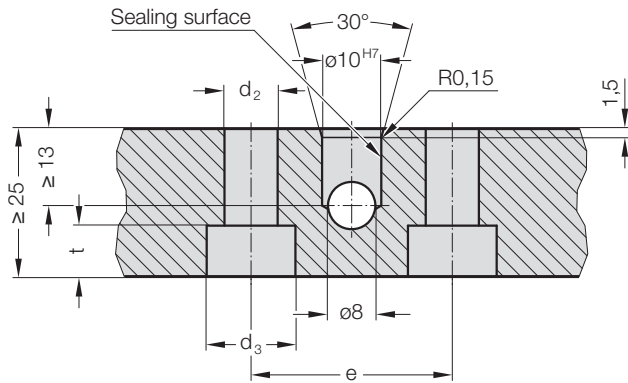

Gas springs

Order No. for composite plate connection

Order No. for composite plate connection	e	d ₂	d ₃	t	n*
2487.94.12.04200.	60	8,4	15	9	4
2487.94.12.06600.	80	10,5	18	11	4
2487.94.12.09500.	100	10,5	18	11	4
2487.94.12.20000.	120	13	20	13	4

* Number of gas spring mounting holes

COMPOSITE PLATE SYSTEM

2487.94.12. – GAS SPRING POWERLINE, FOR COMPOSITE PANEL, WITH CONNECTING NIPPLE

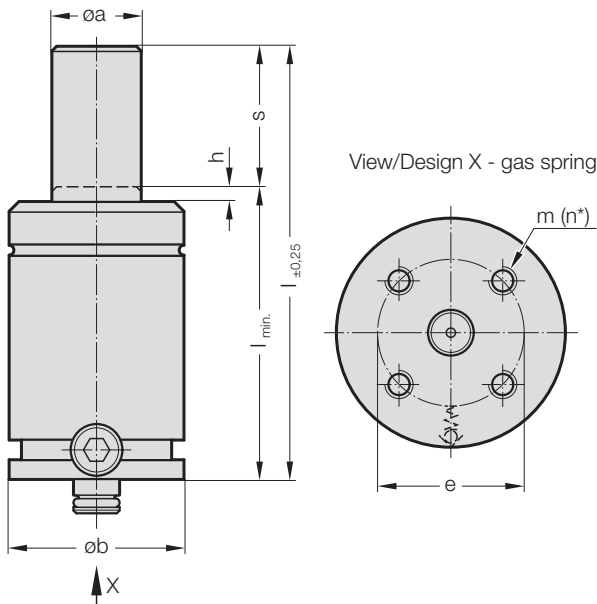

Technical information

Pressure medium:	Nitrogen	N ₂
Max. filling pressure:	180 bar	
Min. filling pressure:	25 bar	
Working temperature:	0°C up to +80°C	
Temperature related force increase:	± 0,3%/°C	
Max. recommended extensions per minute:	approx. 20 up to 100 (at 20°C)	
Max. piston speed:	1,6 m/s	

Ordering Code (example): 2487.94.12.04200.016

Spring force in daN at 150 bar/+20°C

Order No.	Initial spring force	Final force ¹⁾	$\varnothing a$	$\varnothing b$		h	m	n^*	e
2487.94.12.04200.	4200	6170 - 6960	60	95,2	±0,1	3	M8 x 12 deep	4	60
2487.94.12.06600.	6630	9100 - 10650	75	120,2	±0,1	3	M10 x 12 deep	4	80
2487.94.12.09500.	9500	1350 - 15200	90	150,2	±0,1	3	M10 x 13 deep	4	100
2487.94.12.20000.	20000	25900 - 33000	130	195	-0,2	3	M12 x 16 deep	4	120

¹⁾ at full stroke (s) / * Number of gas spring mounting holes

Order No.	Stroke (s)	010	013	016	019	025	032	038	050	063	075	080	100	125
	s	10	13	16	19	25	32	38	50	63	75	80	100	125
2487.94.12.04200.	l	-	-	90	96	108	122	134	158	184	208	218	258	308
	l _{min.}	-	-	74	77	83	90	96	108	121	133	138	158	183
2487.94.12.06600.	l	-	-	100	106	118	132	144	168	194	218	228	268	318
	l _{min.}	-	-	84	87	93	100	106	118	131	143	148	168	193
2487.94.12.09500.	l	-	-	-	116	128	142	154	178	204	228	238	278	328
	l _{min.}	-	-	-	97	103	110	116	128	141	153	158	178	203
2487.94.12.20000.	l	-	-	-	148	160	174	186	210	236	260	270	310	360
	l _{min.}	-	-	-	129	135	142	148	160	173	185	190	210	235

COMPOSITE PLATE SYSTEM

2488.93.13. – GAS SPRING HEAVY DUTY, FOR COMPOSITE PANEL, FLAT SEAL

Connection geometry

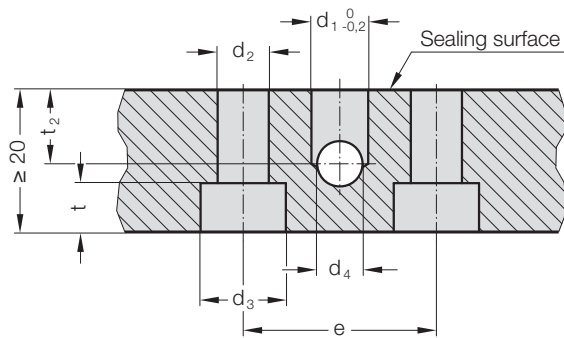

Gas springs Order No. for composite plate connection

connection	e	d ₁	d ₂	d ₃	d ₄	t	t ₂	n*
2488.93.13.00750.	20	5	8,4	15	6	9	6	2
2488.93.13.01000.	20	5	8,4	15	6	9	6	2
2488.93.13.01500.	40	5	8,4	15	8	9	10	4
2488.93.13.02400.	40	5	8,4	15	8	9	10	4
2488.93.13.04200.	60	8	8,4	15	8	9	10	4
2488.93.13.06600.	80	8	10,5	18	8	11	10	4
2488.93.13.09500.	100	8	10,5	18	8	11	10	4
2488.93.13.20000.	120	8	13	20	8	13	10	4

* Number of gas spring mounting holes

COMPOSITE PLATE SYSTEM

2488.93.13. – GAS SPRING HEAVY DUTY, FOR COMPOSITE PANEL, FLAT SEAL

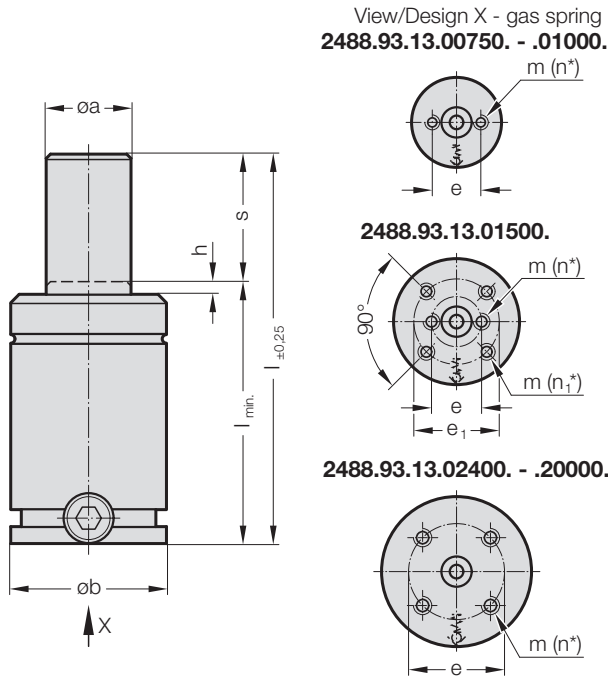

View/Design gas spring with flat seal

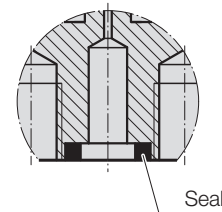

Technical information

Pressure medium: Nitrogen	N ₂
Max. filling pressure:	150 bar
Min. filling pressure:	50 bar
Working temperature:	0°C up to +80°C
Temperature related force increase:	± 0,3%/°C
Max. recommended extensions per minute:	ca. 15 up to 100 (at 20°C)
Max. piston speed:	1,6 m/s

Ordering Code (example): 2488.93.13.00750.013

Spring force in daN bei 150 bar/+20°C

Order No.	Initial spring force	Final force ¹⁾	ϕa	ϕb	\pm	h	m	n^*	n_1	e	e_1
2488.93.13.00750.	740	1200 - 1210	25	45,2	±0,1	2	M8 x 16 deep	2	-	20	-
2488.93.13.01000.	920	1120 - 1490	28	50,2	±0,1	3	M8 x 16 deep	2	-	20	-
2488.93.13.01500.	1500	1770 - 2320	36	63,2	±0,1	3	M8 x 16 deep	2	4	20	40
2488.93.13.02400.	2400	3710 - 3910	45	75,2	±0,1	3	M8 x 16 deep	4	-	40	-
2488.93.13.04200.	4200	5210 - 6870	60	95,2	±0,1	3	M8 x 16 deep	4	-	60	-
2488.93.13.06600.	6630	7950 - 10530	75	120,2	±0,1	3	M10 x 16 deep	4	-	80	-
2488.93.13.09500.	9500	11320 - 14820	90	150,2	±0,1	3	M10 x 16 deep	4	-	100	-
2488.93.13.20000.	20000	19910 - 26830	130	195,0	-0,2	3	M12 x 16 deep	4	-	120	-

¹⁾ at full stroke (s) / * Number of gas spring mounting holes

Order No.	Stroke (s)	013	025	038	050	063	075	080	100	125	150	160	175	200	250	300
	s	13	25	38	50	63	75	80	100	125	150	160	175	200	250	300
2488.93.13.00750.	l	111	135	161	185	211	235	245	285	335	385	405	435	485	-	-
	l_{min}	98	110	123	135	148	160	165	185	210	235	245	260	285	-	-
2488.93.13.01000.	l	121	145	171	195	221	245	255	295	345	395	415	445	495	595	695
	l_{min}	108	120	133	145	158	170	175	195	220	245	255	270	295	345	395
2488.93.13.01500.	l	121	145	171	195	221	245	255	295	345	395	415	445	495	595	695
	l_{min}	108	120	133	145	158	170	175	195	220	245	255	270	295	345	395
2488.93.13.02400.	l	-	160	186	210	236	260	270	310	360	410	430	460	510	610	710
	l_{min}	-	135	148	160	173	185	190	210	235	260	270	285	310	360	410
2488.93.13.04200.	l	-	170	196	220	246	270	280	320	370	420	440	470	520	620	720
	l_{min}	-	145	158	170	183	195	200	220	245	270	280	295	320	370	420
2488.93.13.06600.	l	-	190	216	240	266	290	300	340	390	440	460	490	540	640	740
	l_{min}	-	165	178	190	203	215	220	240	265	290	300	315	340	390	440
2488.93.13.09500.	l	-	205	231	255	281	305	315	355	405	455	475	505	555	655	755
	l_{min}	-	180	193	205	218	230	235	255	280	305	315	330	355	405	455
2488.93.13.20000.	l	--	210	236	260	286	310	320	360	410	460	480	510	560	660	760
	l_{min}	--	185	198	210	223	235	240	260	285	310	320	335	360	410	460

COMPOSITE PLATE SYSTEM

2488.94.13. – GAS SPRING HEAVY DUTY, FOR COMPOSITE PANEL, WITH CONNECTING NIPPLE

Connection geometry

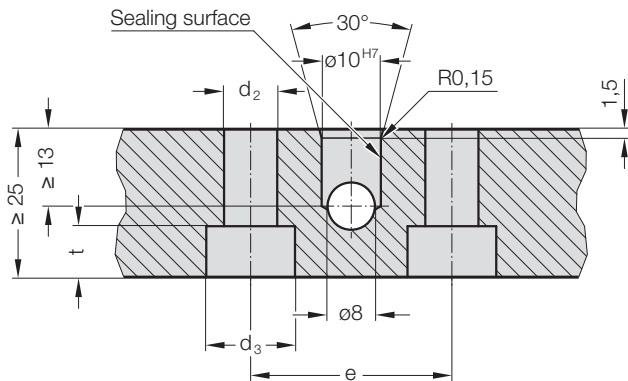

Gas springs Order No. for composite plate connection

	e	d ₂	d ₃	t	n*
2488.94.13.02400.	40	8,4	15	9	4
2488.94.13.04200.	60	8,4	15	9	4
2488.94.13.06600.	80	10,5	18	11	4
2488.94.13.09500.	100	10,5	18	11	4
2488.94.13.20000.	120	13	20	13	4

* Number of gas spring mounting holes

COMPOSITE PLATE SYSTEM 2488.94.13. – GAS SPRING HEAVY DUTY, FOR COMPOSITE PANEL, WITH CONNECTING NIPPLE

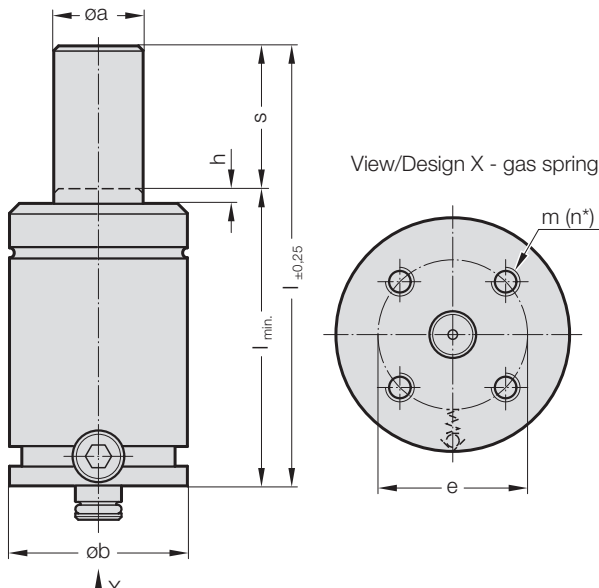

Technical information

Pressure medium:	N ₂
Max. filling pressure:	150 bar
Min. filling pressure:	50 bar
Working temperature:	0°C up to +80°C
Temperature related force increase:	± 0,3%/°C
Max. recommended extensions per minute:	ca. 15 up to 100 (at 20°C)
Max. piston speed:	1,6 m/s

Ordering Code (example): 2488.94.13.02400.025

Spring force in daN at 150 bar/+20°C

Order No.	Initial spring force	Final force ¹⁾	$\varnothing a$	$\varnothing b$	h	m	n^*	e
2488.94.13.02400.	2400	3710 - 3910	45	75,2 ±0,1	3	M8 x 16 deep	4	40
2488.94.13.04200.	4200	5210 - 6870	60	95,2 ±0,1	3	M8 x 16 deep	4	60
2488.94.13.06600.	6630	7950 - 10530	75	120,2 ±0,1	3	M10 x 16 deep	4	80
2488.94.13.09500.	9500	11320 - 14820	90	150,2 ±0,1	3	M10 x 16 deep	4	100
2488.94.13.20000.	20000	19910 - 26830	130	195,0 -0,2	3	M12 x 16 deep	4	120

¹⁾ at full stroke (s) / * Number of gas spring mounting holes

Order No. Stroke (s)	013	025	038	050	063	075	080	100	125	150	160	175	200	250	300
s	13	25	38	50	63	75	80	100	125	150	160	175	200	250	300
2488.94.13.02400.	l	-	160	186	210	236	260	270	310	360	410	430	460	510	610
	l_{min}	-	135	148	160	173	185	190	210	235	260	270	285	310	360
2488.94.13.04200.	l	-	170	196	220	246	270	280	320	370	420	440	470	520	620
	l_{min}	-	145	158	170	183	195	200	220	245	270	280	295	320	370
2488.94.13.06600.	l	-	190	216	240	266	290	300	340	390	440	460	490	540	640
	l_{min}	-	165	178	190	203	215	220	240	265	290	300	315	340	390
2488.94.13.09500.	l	-	205	231	255	281	305	315	355	405	455	475	505	555	655
	l_{min}	-	180	193	205	218	230	235	255	280	305	315	330	355	405
2488.94.13.20000.	l	--	210	236	260	286	310	320	360	410	460	480	510	560	660
	l_{min}	--	185	198	210	223	235	240	260	285	310	320	335	360	410

COMPOSITE PLATE SYSTEM

2490.94.14. – COMPACT GAS SPRING, FOR COMPOSITE PANEL, WITH CONNECTING NIPPLE

Connection geometry

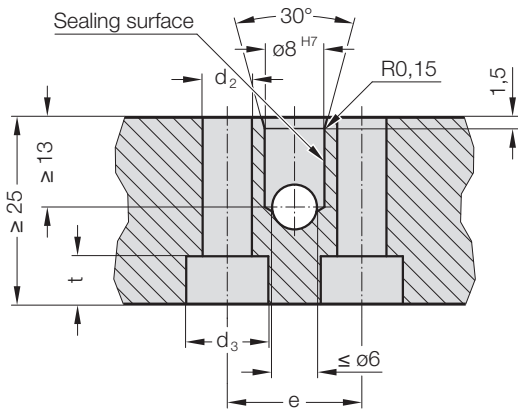

Gas springs

Order No. for composite plate connection

Order No. for composite plate connection	e	d ₂	d ₃	t	n*
2490.94.14.00750.	16	6,4	11	6,8	2
2490.94.14.01000.	17	6,4	11	6,8	2

* Number of gas spring mounting holes

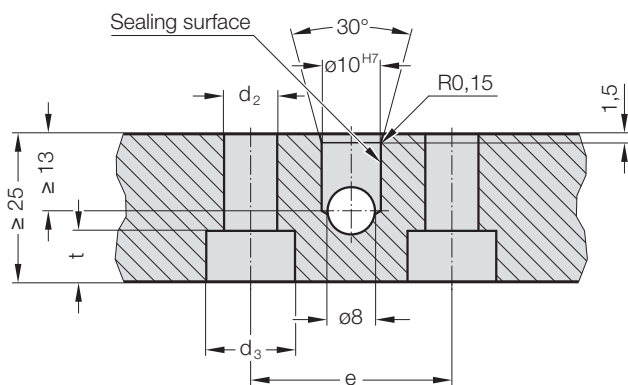

Gas springs

Order No. for composite plate connection

Order No. for composite plate connection	e	d ₂	d ₃	t	n*
2490.94.14.01800.	26	6,4	11	6,8	2
2490.94.14.03000.	34	8,4	15	9	2
2490.94.14.04700.	40	8,4	15	9	4
2490.94.14.07500.	52	8,4	15	9	4
2490.94.14.11800.	68	10,5	18	11	4
2490.94.14.18300.	90	10,5	18	11	4

* Number of gas spring mounting holes

COMPOSITE PLATE SYSTEM

2490.94.14. – COMPACT GAS SPRING, FOR COMPOSITE PANEL, WITH CONNECTING NIPPLE

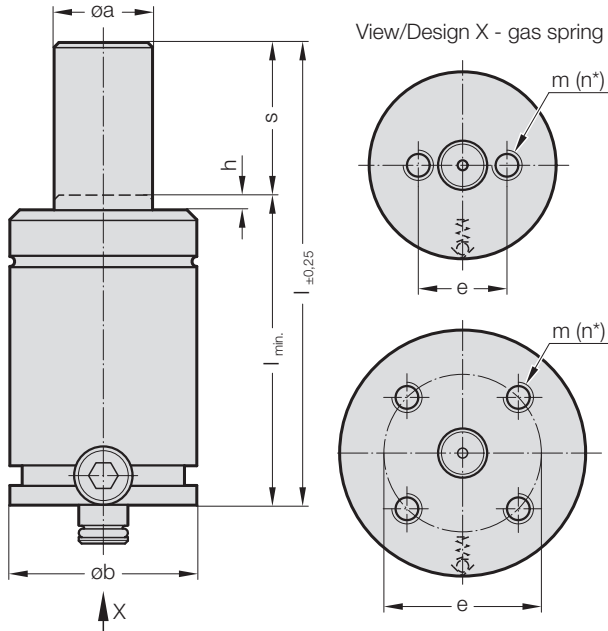

Technical information

Spring size	
Pressure medium: Nitrogen	N ₂
Max. filling pressure:	150 bar
Min. filling pressure:	25 bar
Working temperature:	0°C up to +80°C
Temperature related force increase:	± 0,3%/°C
Max. recommended extensions per minute:	.00750.; .01800. approx. 50 up to 100 (bei 20°C) .01000. approx. 100 (at 20°C) .03000. - .18300. approx. 80 up to 100 (at 20°C)
Max. piston speed:	0,8 m/s

Ordering Code (example): 2490.94.14.00750.010

Spring force in daN at 150 bar/+20°C

Order No.	Initial spring force	Final force ¹⁾	øa	øb	h	m	n*	e
2490.94.14.00750.	740	980 - 1200	20	32 ±0,1	3	M6 x 5,5 deep	2	15
2490.94.14.01000.	1060	1600	20	38 ±0,1	3	M6 x 6,5 deep	2	17
2490.94.14.01800.	1800	2500 - 2900	30	50,2 ±0,1	3	M6 x 6,5 deep	2	26
2490.94.14.03000.	2950	3850 - 4580	38	63,2 ±0,1	3	M8 x 9 deep	2	34
2490.94.14.04700.	4700	6700 - 6800	50	75,2 ±0,1	3	M8 x 9 deep	4	40
2490.94.14.07500.	7500	10400 - 10900	65	95,2 ±0,1	3	M8 x 9 deep	4	52
2490.94.14.11800.	11800	15500 - 17000	80	120,2 ±0,1	3	M10 x 11 deep	4	68
2490.94.14.18300.	18300	23500 - 25500	105	150,2 ±0,1	3	M10 x 11 deep	4	90

¹⁾ at full stroke (s) / * Number of gas spring mounting holes

Order No. Stroke (s)		006	010	016	025	032	040	050	065
	s	6	10	16	25	32	40	50	65
2490.94.14.00750.	l	63	75	93	120	140	165	195	-
	l _{min.}	57	65	77	95	108	125	145	-
2490.94.14.01000.	l	61	78	100	135	167	195	230	-
	l _{min.}	55	68	84	110	135	155	180	-
2490.94.14.01800.	l	66	80	106	135	162	190	220	271
	l _{min.}	60	70	90	110	130	150	170	206
2490.94.14.03000.	l	-	85	103	130	150	175	205	256
	l _{min.}	-	75	87	105	118	135	155	191
2490.94.14.04700.	l	-	80	106	135	167	200	240	273
	l _{min.}	-	70	90	110	135	160	190	208
2490.94.14.07500.	l	-	90	116	145	182	210	255	279
	l _{min.}	-	80	100	120	150	170	205	214
2490.94.14.11800.	l	-	100	126	155	187	220	260	320
	l _{min.}	-	90	110	130	155	180	210	255
2490.94.14.18300.	l	-	110	136	165	197	235	270	323
	l _{min.}	-	100	120	140	165	195	220	258

COMPOSITE PLATE SYSTEM

2497.93.12. – GAS SPRING CX - COMPACT XTREME, FOR COMPOSITE PANEL, FLAT SEAL

Connection geometry

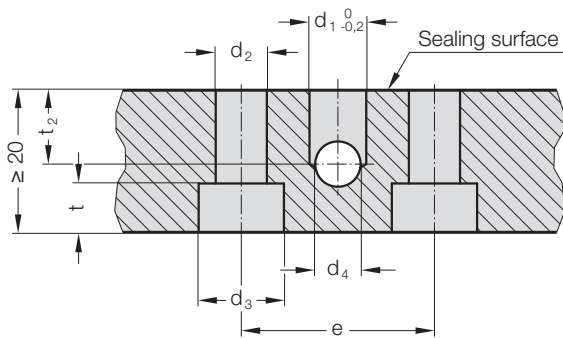

Gas springs

Order No. for composite plate connection

Order No. for composite plate connection	e	d ₁	d ₂	d ₃	d ₄	t	t ₂	n*
2497.93.12.00500.	15	5	6,4	11	6	6,8	6	2
2497.93.12.01000.	17	5	6,4	11	6	6,8	6	2
2497.93.12.01900.	26	5	6,4	11	6	6,8	6	2

* Number of gas spring mounting holes

COMPOSITE PLATE SYSTEM 2497.93.12. – GAS SPRING CX - COMPACT XTREME, FOR COMPOSITE PANEL, FLAT SEAL

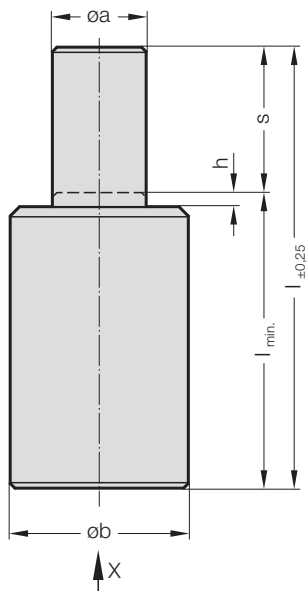

View/Design X - gas spring

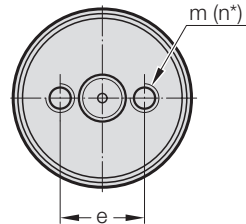

View/Design
gas spring with flat seal

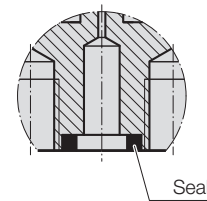

Technical information

Pressure medium: Nitrogen	N ₂
Max. filling pressure:	200 bar
Min. filling pressure:	25 bar
Working temperature:	0°C up to +80°C
Temperature related force increase:	± 0,3%/°C
Max. recommended extensions per minute:	approx. 70 up to 200 (at 20°C)
Max. piston speed:	1,6 m/s

Ordering Code (example): 2497.93.12.00500.015

Spring force in daN at 150 bar/+20°C

Order No.	Initial spring force	Final force ¹⁾	$\varnothing a$	$\varnothing b$	\pm	h	m	n*	e
2497.93.12.00500.	510	660 - 920	32	18	±0,1	3	M6 x 5,5 deep	2	15
2497.93.12.01000.	980	1330 - 1730	38	25	±0,1	3	M6 x 6,5 deep	2	17
2497.93.12.01900.	1920	2630 - 3560	50,2	35	±0,1	3	M6 x 6,5 deep	2	26

¹⁾ at full stroke (s) / * Number of gas spring mounting holes

Order No. Stroke (s)	010	015	025	038	050	063	080
s	10	15	25	38	50	63	80
2497.93.12.00500.	l	75	85	105	130	155	190
	l _{min.}	65	70	80	92	105	127
2497.93.12.01000.	l	75	85	105	135	160	205
	l _{min.}	65	70	80	97	110	142
2497.93.12.01900.	l	80	95	115	150	175	205
	l _{min.}	70	80	90	112	125	142

COMPOSITE PLATE SYSTEM

2497.94.12. – GAS SPRING CX, COMPACT XTREME, FOR COMPOSITE PANEL, WITH CONNECTING NIPPLE

Connection geometry

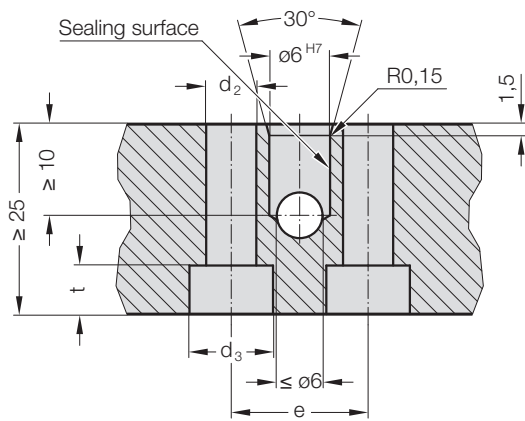

Gas springs

Order No. for composite plate connection

Order No. for composite plate connection	e	d ₂	d ₃	t	n*
2497.94.12.00500.	15	6,4	11	6,8	2
2497.94.12.01000.	17	6,4	11	6,8	2
2497.94.12.01900.	26	6,4	11	6,8	2

* Number of gas spring mounting holes

COMPOSITE PLATE SYSTEM 2497.94.12. – GAS SPRING CX, COMPACT XTREME, FOR COMPOSITE PANEL, WITH CONNECTING NIPPLE

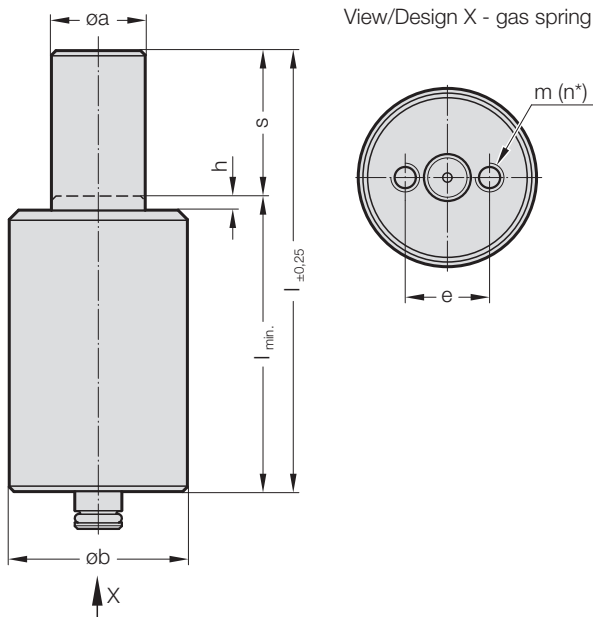

Technical information

Pressure medium: Nitrogen	N ₂
Max. filling pressure:	200 bar
Min. filling pressure:	25 bar
Working temperature:	0°C up to +80°C
Temperature related force increase:	± 0,3%/°C
Max. recommended extensions per minute:	approx. 70 up to 200 (at 20°C)
Max. piston speed:	1.6 m/s

Ordering Code (example): 2497.94.12.00500.015

Spring force in daN at 150 bar/+20°C

Order No.	Initial spring force	Final force ¹⁾	oa	ob	h	m	n*	e	
2497.94.12.00500.	510	660 - 920	32	18	±0,1	3	M6 x 5,5 deep	2	15
2497.94.12.01000.	980	1330 - 1730	38	25	±0,1	3	M6 x 6,5 deep	2	17
2497.94.12.01900.	1920	2630 - 3560	50.2	35	±0,1	3	M6 x 6,5 deep	2	26

¹⁾ at full stroke (s) / * Number of gas spring mounting holes

Order No. Stroke (s)	010	015	025	038	050	063	080
s	10	15	25	38	50	63	80
2497.94.12.00500.	l	75	85	105	130	155	190
	l _{min.}	65	70	80	92	105	127
2497.94.12.01000.	l	75	85	105	135	160	205
	l _{min.}	65	70	80	97	110	142
2497.94.12.01900.	l	80	95	115	150	175	245
	l _{min.}	70	80	90	112	125	165

COMPOSITE PLATE SYSTEM

2480.94.00.31.01.11 – CONTROL FITTING WITH FLOOR CONNECTION

The control valves offer a horizontal (floor) as well as vertical (wall) connection option. Refer to the corresponding connection drawing for the mounting holes.

The central connection offers the user the option to monitor, adjust as required, fill and drain the composite plate system outside the tool.

Depending on its application, the control fitting can either be attached directly to the composite plate or attached to any point of the tool by means of a mini measuring hose.

Depending on the plate thickness, multiple pressure circuits in the composite plate are also possible.

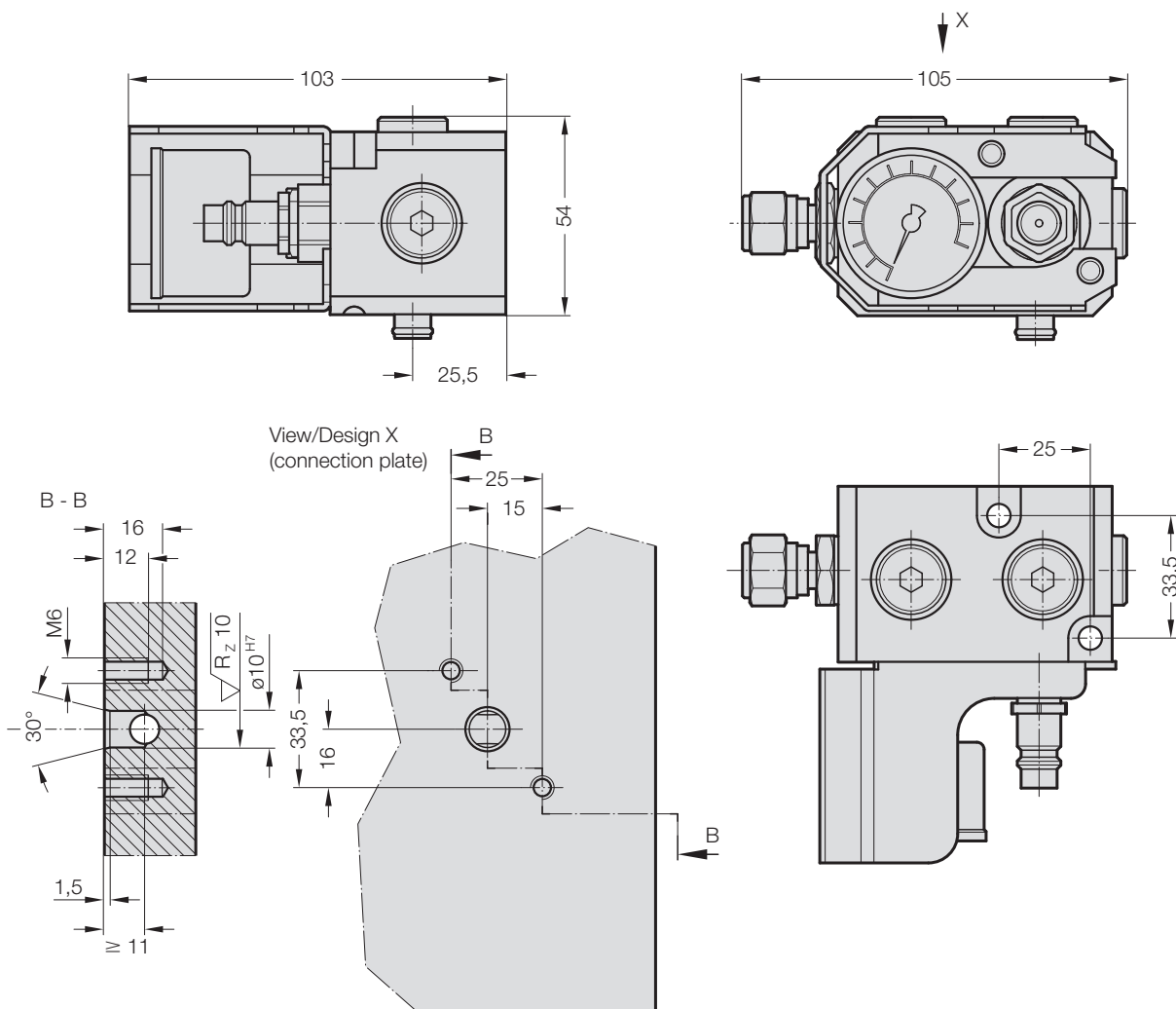

COMPOSITE PLATE SYSTEM 2480.94.00.31.01.12 – CONTROL FITTING WITH WALL CONNECTION

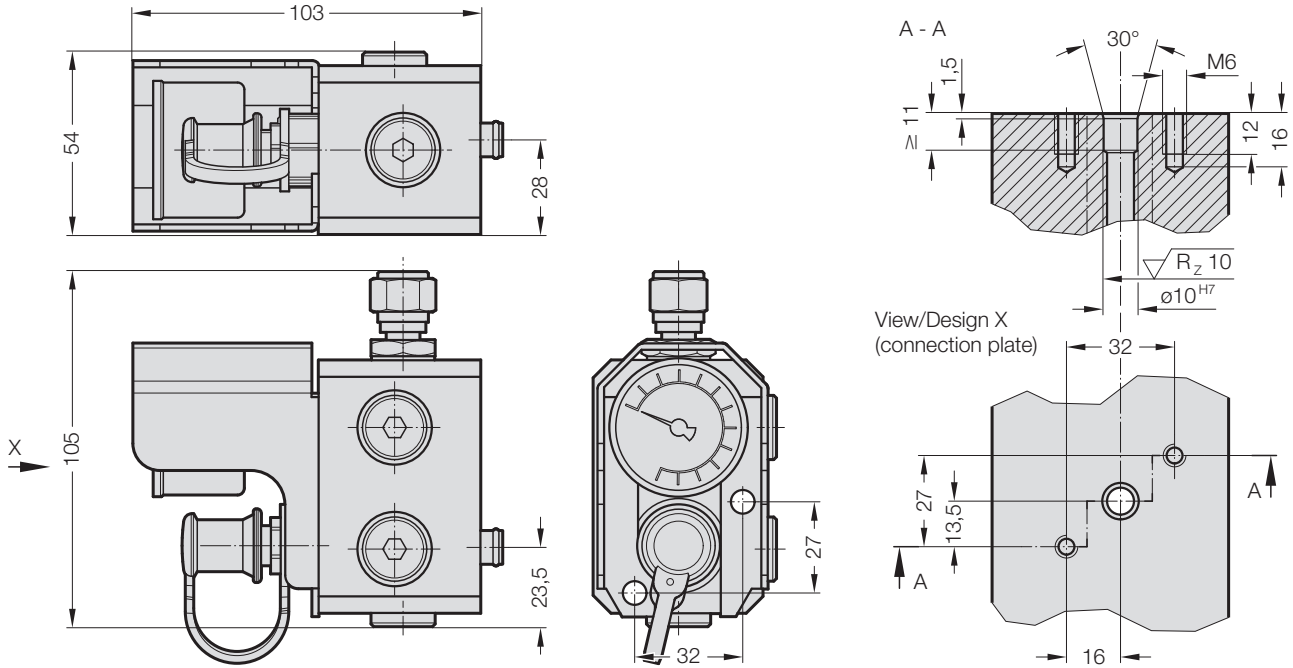

COMPOSITE PLATE SYSTEM

2480.00.31.0X.1 – CONTROL FITTING WITH HOSE FASTENING

- 2480.00.31.01.1 without pressure switch
- 2480.00.31.06.1 with pressure switch
- 2480.00.31.07.1 without pressure switch and with pressure relief
- 2480.00.31.08.1 with pressure switch, with pressure relief

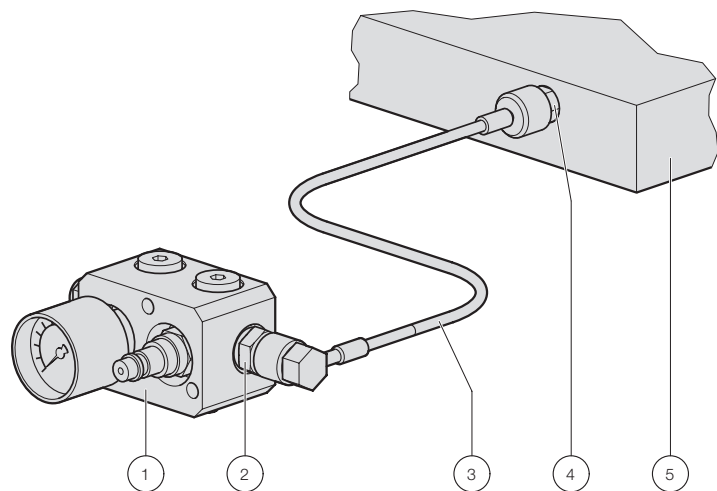
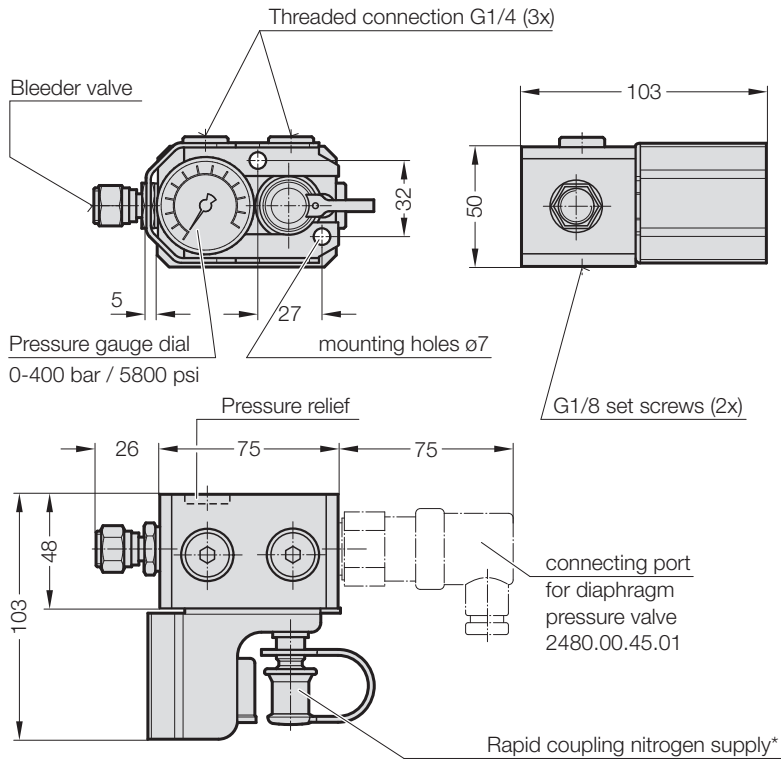

Item	Description	Order No.
1	Control fitting	2480.00.31.0x.1
2	Measuring coupling without valve G1/4	2480.00.24.04
3	Gauging hose one end straight / 90°-angle	2480.00.23.02.xxxx
4	Measuring coupling without valve G1/8	2480.00.24.03
5	Composite plate	2494. ...

COMPOSITE PLATE SYSTEM 2480.00.24. – GAUGING COUPLING

2480.00.24.03/04

Measuring coupling 2480.00.24.03 without valve for screwing into the composite plate

Measuring coupling 2480.00.24.04 without valve for screwing into the control fitting

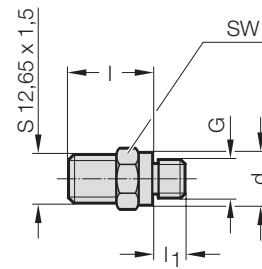

Order No.	G	d	l	l ₁	SW
2480.00.24.03	G 1/8	14	22	8	14
2480.00.24.04	G 1/4	19	21	10	19

SW = Width across flats

COMPOSITE PLATE SYSTEM

2480.00.23. – MINIMESS – COMPOUND

THREADED JOINTS

2480.00.23.01.

Gauging hose -
both ends straight

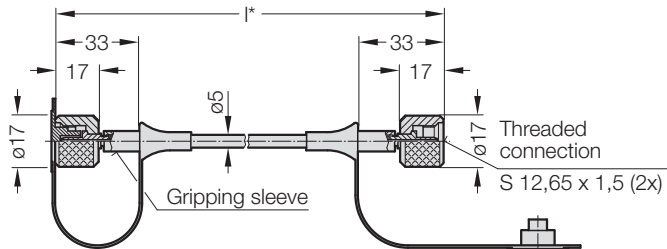

2480.00.23.01.-----1

Antikink spiral, at one end

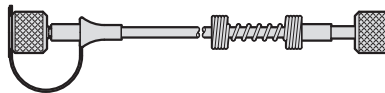

2480.00.23.01.-----2

Antikink spiral, at both ends



2480.00.23.01.

Order No.	l*
2480.00.23.01.0200	200
2480.00.23.01.0300	300
2480.00.23.01.0400	400
2480.00.23.01.0500	500
2480.00.23.01.0630	630
2480.00.23.01.0800	800
2480.00.23.01.1000	1000
2480.00.23.01.1200	1200
2480.00.23.01.1500	1500
2480.00.23.01.2000	2000
2480.00.23.01.2500	2500
2480.00.23.01.3000	3000

* Other lengths available in 5 mm steps!

shortest factory lengths:	
without antikink protection	90 mm
antikink protection at one end	150 mm
antikink protection at both ends	300 mm

2480.00.23.02.

Gauging hose -
one end straight
90°-angle

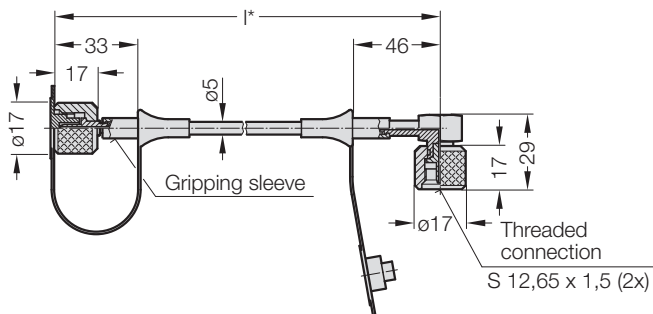

2480.00.23.02.-----1

Antikink spiral, at one end, straight

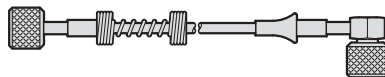

2480.00.23.02.-----2

Antikink spiral, at both ends



2480.00.23.02.-----3

Antikink spiral, at one end, 90°

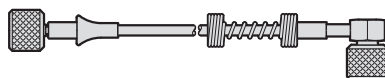

2480.00.23.02.

Order No.	l*
2480.00.23.02.0200	200
2480.00.23.02.0300	300
2480.00.23.02.0400	400
2480.00.23.02.0500	500
2480.00.23.02.0630	630
2480.00.23.02.0800	800
2480.00.23.02.1000	1000
2480.00.23.02.1200	1200
2480.00.23.02.1500	1500
2480.00.23.02.2000	2000
2480.00.23.02.2500	2500
2480.00.23.02.3000	3000

* Other lengths available in 5 mm steps!

shortest factory lengths:	
without antikink protection	90 mm
antikink protection at one end	150 mm
antikink protection at both ends	300 mm

COMPOSITE PLATE SYSTEM

2480.00.23. - MINIMESS - COMPOUND THREADED JOINTS

2480.00.23.03.

Gauging hose -
 both ends
 90°-angle

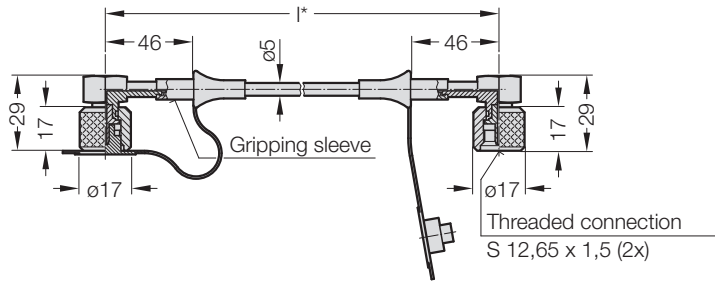

2480.00.23.03.

Order No.	l*
2480.00.23.03.0200	200
2480.00.23.03.0300	300
2480.00.23.03.0400	400
2480.00.23.03.0500	500
2480.00.23.03.0630	630
2480.00.23.03.0800	800
2480.00.23.03.1000	1000
2480.00.23.03.1200	1200
2480.00.23.03.1500	1500
2480.00.23.03.2000	2000
2480.00.23.03.2500	2500
2480.00.23.03.3000	3000

* Other lengths available in 5 mm steps!

2480.00.23.03.-----3

Antikink spiral, at one end

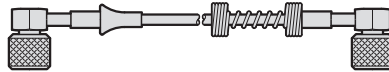

2480.00.23.03.-----2

Antikink spiral, at both ends



shortest factory lengths:	
without antikink protection	105 mm
antikink protection at one end	150 mm
antikink protection at both ends	300 mm

COMPOSITE PLATE SYSTEM

248.00.43.2 – PIPE PLUG

2480.00.30.0005 – PIPE PLUG

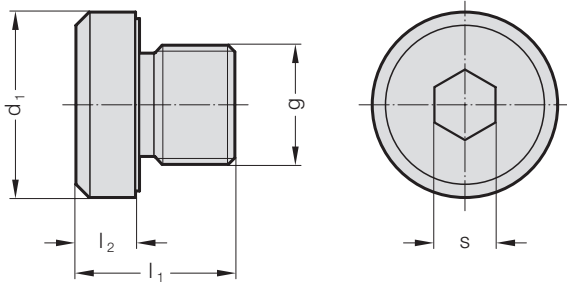

Description	Order No.	d ₁	g	l ₁	l ₂	s
Pipe plug G1/8	248.00.43.2	14	G1/8	12	4	5
Pipe plug G1/4	2480.00.30.0005	19	G1/4	17	4	6

Connection geometry of locking screw

Locking screws are used to seal the through-holes.

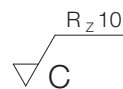
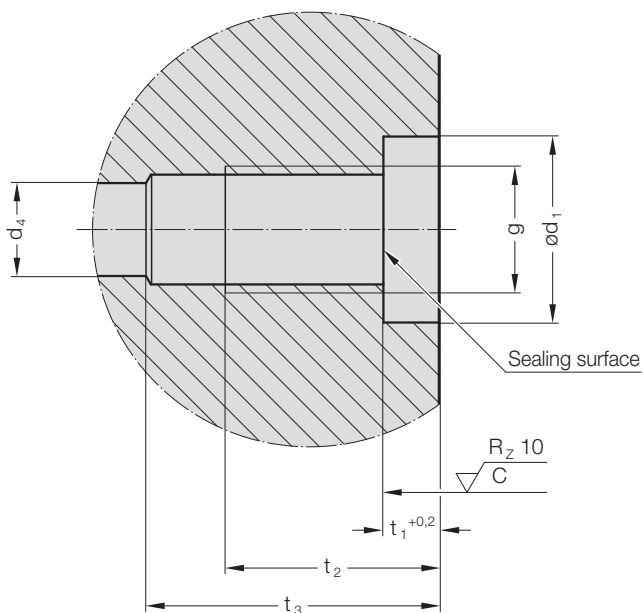

Specification of the surface composition/texture based on DIN EN ISO 1302

Depiction of the groove direction:



Symbol: C

Groove direction: nearly centric to the centre point

d ₄	g	d ₁	t ₁	t ₂	t ₃	Pipe plug
≤ 8	G1/8	16	5	15,5	20	248.00.43.2
> 8	G1/4	20	6	20	25	2480.00.30.0005

COMPOSITE PLATE SYSTEM 2480.93.00.40. – COVER DISK

Cover disc incl. sealing ring, can only be used for flat gaskets

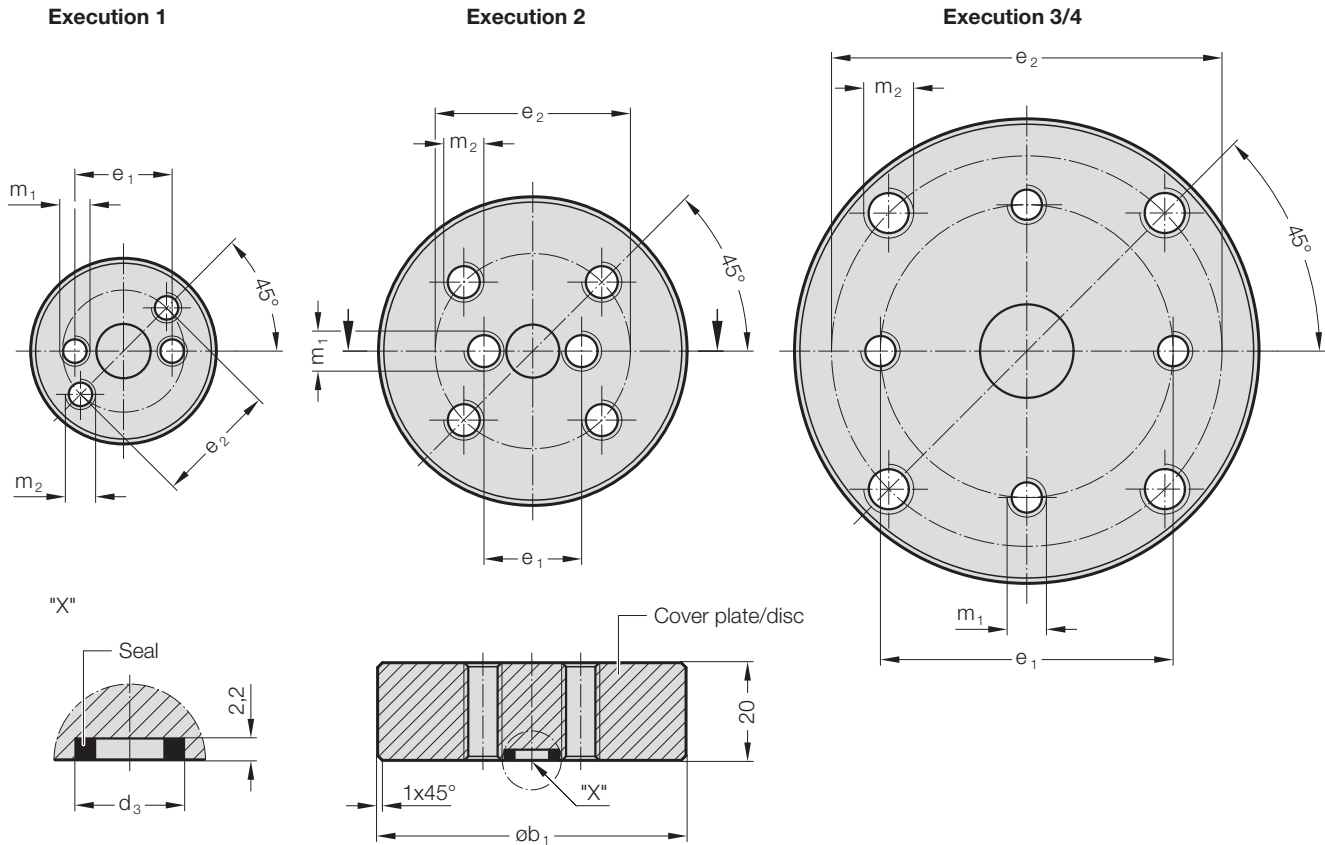

Order No. Cover disc incl. sealing ring	Execution	$\varnothing b_1$	m_1	e_1	m_2	e_2	m_3	d_3	t_1	Gas spring
2480.93.00.40.01	1	38	M6 (2x)	20	M6 (2x)	25	M8 (2x)	11,1	10	2487.93.12.00350.
										2487.93.12.00500.
										2480.93.13.00500.
										2480.93.13.00750.
										2487.93.12.00750.
										2487.93.12.01000.
										2487.93.12.01500.
										2488.93.13.00750.
2480.93.00.40.02	2	60	M6 (2x)	20	M6 (2x)	40	--	11,1	16	2488.93.13.01500.
										2488.93.13.02400.
										2480.93.13.03000.
										2480.93.12.01500.
2480.93.00.40.03	3	95	M8 (4x)	60	M10 (4x)	80	--	19	20	2480.93.13.05000.
										2487.93.12.04200.
										2487.93.12.06600.
										2488.93.13.04200.
										2488.93.13.06600.
										2480.93.13.07500.
2480.93.00.40.04	4	150	M10 (4x)	100	M12 (4x)	120	--	19	20	2480.93.12.10000.
										2487.93.12.09500.
										2487.93.12.20000.
										2488.93.13.09500.
										2488.93.13.20000.

FIBRO

THE SAFER CHOICE

At FIBRO, safety and reliability are paramount. Particularly when it comes to our gas springs. With their unique range of safety features, FIBRO gas springs are one of the safest on the market.

The safety features mentioned here have been implemented – with few exceptions – on all FIBRO gas springs.

Please refer to the relevant data sheets to check the current safety equipment which is provided with the gas spring you are interested in, or contact FIBRO GmbH directly for more information.

After a protection function is triggered, the spring cannot be repaired and can no longer be used. It must be replaced completely.

For the safe handling of gas springs and other nitrogen products, the safety regulations must be observed. Maintenance work on the product may only be done, if nitrogen gas is no longer contained in the gas spring.

FIBRO SAFETY FEATURES



PED approval for 2 million strokes

FIBRO gas springs are developed, manufactured and tested for a minimum of 2 million* full strokes in accordance with PED 2014/68/EU. The springs deliver this full performance at the maximum permissible limits in terms of filling pressure and operating temperature – even when combined with any of the various mounting types available.

* Calculation value for durability

The benefit for you:

- Guaranteed safety and reliability for the entire service life of the spring

Repair kits and qualified training sessions available through FIBRO Service offer increased effectiveness and process reliability.



Overstroke protection

Conventional gas springs may burst in the event of an over-extended stroke. Components may come loose and be ejected.

FIBRO gas springs are different:

in the event of an overstroke and depending on the spring type the patented protection system will ensure that either the cylinder wall of the gas spring is deformed in a predefined manner (A) or the piston rod destroys a rupture bolt in the floor of the cylinder (B), thereby allowing the gas to escape into the atmosphere.

The benefit for you:

- Safe working environment and reduced risk of damage to the tool

Possible causes of triggering:

Lack of stroke limitations in the tool/machine and placing the piston rods under a load (e.g. sheet-metal holder, slide reset, etc.), double sheet, incorrect installation position, etc.

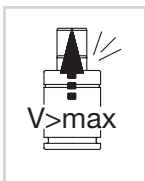

Return stroke protection

If, for any reason, tool components should get stuck and the piston rod should be freely released from its compressed position, conventional gas springs may pose a safety risk as the piston may not be retained in the gas spring.

FIBRO gas springs are different:

Special guides and a patented safety stop in the piston rods ensure your safety. If the speed is too high during the return stroke, the collar on the piston rod will automatically break. The integrated safety stop then destroys the seal, which allows the gas to escape into the atmosphere and the gas spring to become depressurised.

The benefit for you:

- Safe working environment and reduced risk of damage to the tool

Possible causes of triggering:

Sudden loosening of jammed components, such as sheet-metal holder, slide, ejector, scraper function, etc.

FIBRO RELIABILITY FEATURES



Overpressure protection

Conventional gas springs can burst if the internal pressure rises above a maximum permitted value. This may pose a safety risk for operators and tools.

FIBRO gas springs are different:

if the pressure rises above the maximum permitted value, the safety collar on the sealing set is automatically destroyed. The gas then escapes into the atmosphere and the gas spring is depressurised.

The benefit for you:

- Safe working environment and reduced risk of damage to the tool

Possible causes of triggering:

Incorrect filling (max. filling pressure 150 or 180 bar, nitrogen), infeed of liquid operating material, etc.

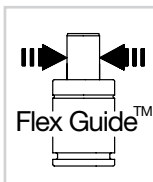

Flexible guides: The Flex Guide™ System

The Flex Guide™ System is a flexible guide in the gas spring which absorbs lateral movements of the piston rod. It minimises friction and lowers the operating temperature.

The benefits for you:

- Extended service life
- Increased stroke frequency, i.e. more strokes per minute



Safe hose connections: The Dual Seal™ System

The FIBRO Dual Seal™ System combines a metal seal with a soft elastomer seal. On hose connection systems, the system provides two leak-tight connections and prevents rotation.

The benefits for you:

- Leak-tight connection, even under vibrations
- High process reliability
- Minimised tool down time
- Simple installation thanks to anti-rotation function



Wireless monitoring: The Wireless Pressure Monitoring (WPM) system

The optional Wireless Pressure Monitoring System (WPM) (patent pending) wirelessly monitors the pressure and temperature of FIBRO gas springs. Before a defective part is produced, the press operator receives a message from the WPM and can take appropriate action.

The benefits for you:

- Preventative quality assurance
- High process reliability
- Minimised tool down time
- Reduced maintenance and costs

Potential faults are individually displayed. As a result, service intervals can be extended. Maintenance and repair costs are reduced.



Protected piston rods: FIBRO Concertina Shrouds

The FIBRO Piston Rod Protection (patented) reliably protects the piston rods in gas springs against dirt, oil and emulsion. In this way, the system prevents damage to the piston rod surface and leaks at internal seals.

The benefit for you:

- Significantly longer service life for gas springs under harsh operating conditions

FIBRO GMBH

Geschäftsbereich Normalien
August-Läpple-Weg
74855 Hassmersheim
GERMANY
T +49 6266 73-0
info@fibro.de
www.fibro.com

THE LÄPPLE GROUP

LÄPPLE AUTOMOTIVE
FIBRO
FIBRO LÄPPLE TECHNOLOGY
LÄPPLE AUS- UND WEITERBILDUNG