

OPERATING INSTRUCTIONS

WPM DATA HOLDER

2480.00.91.30



Document: Operating instructions

Document number: 2.7546.01.0420.0100000

Revision: R04-2020

Version: V01

Language:



In the German language, this document is the original version in the EU language of the manufacturer and is labelled with the German national flag.

In the language of a country of use, this document is a translation of the original version and labelled with the national flag of the country of use.

This document is referred to as "instructions" in the following text.

Number of pages in this manual including the title page: 22

These instructions are valid for the product

2480.00.91.30

WPM Data Holder

This document was created by

FIBRO GMBH

August-Läpple-Weg

DE 74855 Hassmersheim

Phone: +49 (0) 62 66 73 0

Fax: +49 (0) 62 66 73 237

E-mail: info@fibro.de

Internet: www.fibro.de

© All rights to this document are subject to copyright of the author.

Without the prior written permission of FIBRO GMBH, this document must not be copied or reproduced, either in full or in part.

The instructions are intended only for the operator of the described Component only and must therefore not be made available to uninvolved third parties - in particular to competitors.

Contents

1	Introduction	4
1.1	Intended use	4
1.2	Foreseeable misuse	5
1.3	Due diligence of the operator	5
1.4	Scope of application	6
1.5	Disclaimer of liability	6
1.6	Purpose of the document	6
1.7	Definitions	7
1.8	Target group	7
1.9	Autor's rights	7
1.10	Qualifications of personnel	8
2	Safety	9
2.1	Safety instructions	9
2.2	General instructions	9
3	Product description	10
3.1	Components and properties	10
3.2	Accessories	10
3.3	Technical data	10
3.3.1	Technical drawing	11
3.3.2	Type plate	11
4	Assembly	12
4.1	Constructive requirements	12
5	Commissioning	13
6	Operation	15
6.1	Configuration operation	15
6.2	Normal operating modes	15
6.2.1	Normal operation	15
6.2.2	Tool check	15
6.2.3	Pairing confirmation for WPM Gateway	16
6.3	Operating mode battery empty	16
7	Maintenance	17
7.1	Changing the lithium metal battery	17
8	Disposal	18
8.1	Disposing of the battery	18
9	Indexes	19
9.1	Third-party products	19
9.2	Index of tables	19
10	Appendix	20
10.1	Personal notes	20
11	Index	21

1 INTRODUCTION

Read through these instructions carefully before use and store them.

These instructions contain the following important information on the product:

- Proper use
- Safety
- Mounting
- Use
- Maintenance
- Disposal

Proper use also involves

- Reading these instructions
- Complying with the safety information they contain
- Complying with the applicable documents
- Complying with the maintenance requirements

Give these instructions to the user after mounting is complete, and give them to the new owner if the product is sold.

1.1 Intended use

- This product is intended only for industrial use in the territory of the European Union and in countries that have been recognised by standards and certificates of the European Union.



Country-specific restrictions may exist concerning communication via Bluetooth outside of the European Union.

- The WPM system is intended only for industrial use in machinery and plant technology.
- The product is a telecommunications product.
- The product may be used only in a technically flawless state, for its intended use, in compliance with the relevant provisions and with safety and potential dangers kept in mind.
- Detected disruptions, especially those which could impair safety, must be redressed immediately.

All forms of usage deviating from the one described in the section on proper use and in the relevant documentation is not proper and is thus prohibited.

- The distributing companies and manufacturers assume no liability for damage in the event of improper use.
- The manufacturer assumes no liability for equipment, its usage and consequences.
- The operator shall be the sole bearer of all risks associated with improper use.

1.2 Foreseeable misuse

Any use that does not comply with the intended use, is considered misuse of the product and is prohibited.

The product must not be stressed beyond its load limits.

The following instances, among others, are considered misuse:

- It is used for applications which the manufacturer has not explicitly approved. The statements contained in the safety notes in the relevant documentation must be observed!
- Construction changes that destroy the original state.
- Improper system programming or configuration. The operator bears sole responsibility and risks for using, programming and configuring the system.
- Usage in explosive atmospheres.
- Usage in explosive areas.
- Usage in medical areas.
- Usage in residential areas.
- Usage in applications that are relevant to security.
- Private use.

1.3 Due diligence of the operator

This Component is designed and manufactured by FIBRO GMBH according to the state of the art. The requirements for ensuring safety and protection of health have been fulfilled.

However, this safety can be achieved in operational practice only when all required applicable measures have been taken. The operator of the Component must plan these measures and control their implementation.

The operator is responsible for the safe operation of the Component.

The operator must make sure that

- the Component is used only as intended.
- the Component must be operated only in a fully functional state with all mechanical and electrical safety devices in place.
- a copy of these instructions and of all other applicable documents is always available in a complete and legible condition at the operation site of the Component. All persons required to work with the Component must be able to consult these instructions at any time.
- only personnel in accordance with 1.10 "Qualifications of personnel" is used at the Component.
- personnel are familiar with these instructions, in particular with the safety information contained therein.
- the responsibilities of this personnel are clearly defined and observed.
- personnel are regularly instructed in all applicable issues related to occupational health and safety and environmental protection.
- all danger signs fitted to the Component have not been removed and remain legible.
- operating instructions related to the work safety and accident prevention are enacted.
- national accident prevention regulations and company regulations are complied with.
- personal protective clothing is available where required.

1.4 Scope of application

These instructions apply to the product with the description "WPM Data Holder" manufactured by FIBRO GMBH DE 74855 Hassmersheim.

If you do not have the proper instructions for your product, contact FIBRO GMBH DE 74855 Hassmersheim.

1.5 Disclaimer of liability

FIBRO GMBH guarantees the described function of the product as stated in advertising and product information.

Further product properties are not confirmed. FIBRO GMBH assumes no liability for efficiency and flawless functioning if the product is used for a purpose other than the one addressed in the chapter "Proper use". Compensation for damage is generally precluded.

If this product is used in environments for which it is not suitable or which do not fulfil the technical standards, FIBRO GMBH shall not be held responsible for the consequences.

FIBRO GMBH assumes no liability for damage to facilities and systems near the product caused by a defect in the product or an error in these instructions.

FIBRO GMBH is not responsible for the violation of patents and/or the rights of third parties outside of the Federal Republic of Germany.

FIBRO GMBH is not responsible for damage caused by improper operation and failure to follow the instructions provided in this document.

FIBRO GMBH is not liable for lost profit and subsequent damage resulting from failure to comply with safety and warning notes.

The products from FIBRO GMBH are state of the art in science and technology.

FIBRO GMBH continually conducts studies of the products and the market in order to continually improve and further develop its products.

1.6 Purpose of the document

These instructions describe the operation of the product and contain important information on correct use.



Read these instructions before working on or with the product. The instructions contain important information for your personal safety. All persons who work on or with the product at some phase in the product's life must read and understand the instructions.

The instructions must be available at the location where the product is used and throughout its entire lifespan. They must be given to the new owner if the product is sold.

The safety notes in the individual chapters must be observed.

These instructions and the other applicable documents are not subject to an automatic change service.

We reserve the right to make changes to the data and figures mentioned in these instructions due to technical developments. FIBRO GMBH can supply the current issue.

1.7 Definitions

The following table lists terms and gives a short explanation for getting started.

Some terms are described in detail in the “Product description” chapter.

Term	Definition of terms
Users	Users are people who have been created in the system.
Operator	Person or organisation which uses the product or system responsibly.

Tab. 1-1 Definition of terms

1.8 Target group

These instructions are oriented towards persons who commission, configure, operate and maintain the product WPM Data Holder.

1.9 Autor's rights

The product WPM Data Holder and these instructions are protected by copyright. Reproduction without approval shall be prosecuted in court.

We reserve all rights to these instructions, including reproduction and/or copying in all imaginable forms, e.g. by photocopying, printing, copying to any data media whatsoever and in translated form.

These instructions may be reprinted only with written approval from FIBRO GMBH.

The technical state at the time of the delivery of the product WPM Data Holder and the associated instructions shall be decisive if no other information is provided.

We reserve the right to make technical changes without giving special notice. Earlier instructions shall lose their validity. The general sales and delivery conditions of FIBRO GMBH apply.

The products, names and logos mentioned serve informational purposes only and may be trademarks of the respective owner. This shall require no special indication.

1.10 Qualifications of personnel

Special qualifications are required for personnel performing specific tasks.

Among other things, knowledge of first aid measures and local rescue facilities is required.

Electrical equipment	Qualified experts from the electrical trade (as defined for specialists in IEC 364)
Transport	Trained personnel
Assembly work	Trained personnel
Commissioning	Trained personnel
Inspections	Instructed personnel
Cleaning	Instructed personnel
Maintenance	Trained personnel
Repair	Qualified expert
Decommissioning	Qualified expert
Disassembly	Qualified expert
Operation	Instructed personnel
Troubleshooting	Trained personnel
Changing control parameters	Qualified experts

Tab. 1-2 Qualifications of personnel

Qualified experts are persons who, due to their education, experience, training, and knowledge of relevant standards, provision, accident prevention regulations, and operating conditions, are authorised to perform the required tasks whilst recognising and preventing possible dangers.

Trained personnel are persons who have been trained by the manufacturer or the operating company for a specific set of tasks or activities. Trained personnel are authorised to perform the tasks or activities which correspond to the level of knowledge achieved from the training. Trained personnel have been informed about possible dangers and can recognise and avoid/prevent these.

Instructed personnel are persons who have been authorised by the manufacturer or the operating company to perform a specific set of tasks or activities independently.

2 SAFETY

2.1 Safety instructions

These instructions contain safety notices intended to draw attention to possible dangers that should be observed to prevent injury.

The pertinent text describes

- the type of danger
- the source of danger
- the options for preventing injuries
- the consequences in case of non-observance of the warning notices

The safety instructions are emphasised by a colour signal bar with warning triangle and signal word.

The signal bars have the following meaning:

 **DANGER!**

A safety notice on a red signal bar with the signal word DANGER designates a hazard with a high risk level which, if not avoided, will result in death or severe injury.

 **WARNING!**

A safety notice on an orange signal bar with the signal word WARNING designates a hazard with a medium risk level which, if not avoided, might result in death or severe injury.

 **CAUTION!**

A safety notice on a yellow signal bar with the signal word CAUTION designates a hazard with a low risk level which, if not avoided, could result in minor or moderate injury.

2.2 General instructions

In addition to the safety notices, these instructions contain information that must be observed to prevent property damage.

The pertinent text describes

- the possible reason for property damage
- the possibilities for preventing property damage

Notices of possible property damage are emphasised by a blue signal bar and the signal word *ATTENTION*.

NOTICE

Notices for the prevention of property damage are not related to possible injuries.



Furthermore, these instructions contain general information on use.

General information on use and tips for certain applications are emphasised with a blue information symbol.

3 PRODUCT DESCRIPTION

3.1 Components and properties

The product WPM Data Holder is part of the pressure monitoring system. It is a component specially developed for monitoring and registering

FIBRO WPM Pressure Sensors located inside or outside of a registered pressing tool.

In the following text of these instructions, the product WPM Data Holder is referred to as Component.

The WPM Data Holder transmits measured data and status information using the Bluetooth LE 4.0 standard in the FIBRO payload protocol.

In addition, the following work together: the WPM Pressure Sensor, the WPM Gateway to be included in the local PLC, and the WPM configuration software, theWPM app, as well as additional programmes with the WPM Data Holder used only in FIBRO's plant.

3.2 Accessories

No additional accessories are planned for the WPM Data Holder.

Two lithium metal batteries from FIBRO are needed for operation. In keeping with the evaluation of the measured data and statuses of the WPM Data Holder, they must be replaced on a regular basis to ensure proper functioning.

3.3 Technical data

Voltage supply:	3.6V, 2 FIBRO lithium metal batteries
Temperature range:	-10°C to +80°C
Protection class:	IP65, glued and screwed together
Size:	44 mm x 50 mm x 111 mm
Weight:	0.3 kg
Plastic housing:	PA6
Flange plate:	Aluminium
Operation and display:	2 keys and 2 bi-colour LEDs (red/green)
Radio technology:	Bluetooth LE 4.0 2.4 GHz
Permitted countries:	The territory of the European Union and countries which have been recognised by standards and certificates of the European Union USA and Canada

The battery contains the hazardous material lithium thionyl chloride

3.3.1 Technical drawing

2480.00.91.30

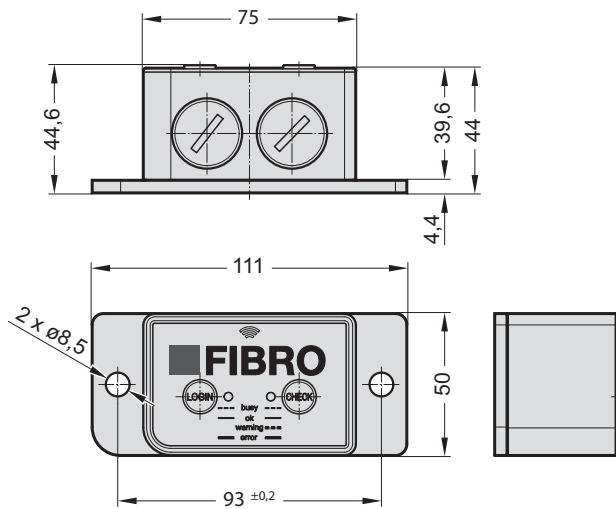

3.3.2 Type plate

Device identification EU



Device identification EU USA Canada



4 ASSEMBLY

The FIBRO gas springs in the pressing tool must be equipped with FIBRO WPM Pressure Sensors.

The WPM Data Holder is mounted on the pressing tool at a mechanically protected location that is easy to see. Two M6 screws are used to attach it. The screws must be effectively secured against unintentional loosening.

The WPM Data Holder may be aligned vertically or horizontally when mounted.

The radio's transmission direction is always indicated symbolically on the upper side (with the label "FIBRO") of the WPM Data Holder.

The operator should be able to access the labelled side that has the keys.

4.1 Constructive requirements

Much more than 10 mm of space must be kept free around the WPM Data Holder with the exception of the side where it is attached.

The area of the WPM Data Holder labelled with a radio symbol must not be covered or come into direct contact with metallic surfaces.

For operation with radio technology, the Data Holder must be mounted so that the line of sight to the corresponding WPM Gateway is unimpeded.

Fluids that wet the data holder may reduce the radio transmission.

5 COMMISSIONING

The FIBRO gas springs must be equipped with WPM Pressure Sensors.

Both lithium metal batteries must be connected and inserted into the WPM Data Holder.

So that this can happen, the metal locking screws are opened using a suitable tool.

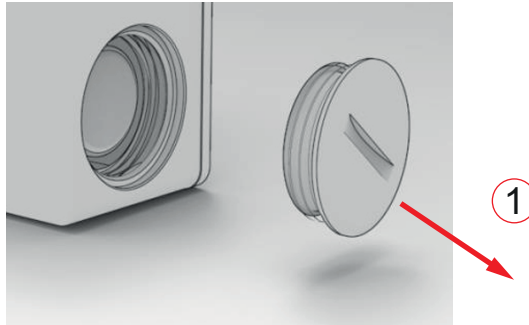

1 Removing the plug

The plug connector for the batteries is inserted into the relevant connection socket inside the WPM Data Holder, where it clicks into place audibly.

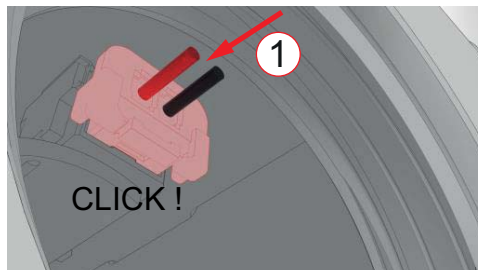

1 Inserting and clicking into place

The batteries are then inserted into the battery chamber with the shorter part of each battery facing forward towards the litz wire outlet.

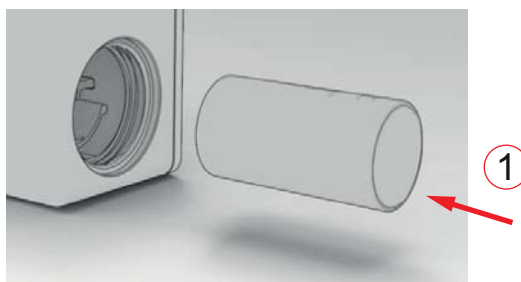

1 Inserting and securing the line

It is necessary to make sure that the litz wire is located entirely inside the chamber. It must not be located above the battery.

After the battery is inserted, the metal locking screw needs to be screwed again and sealed tightly.

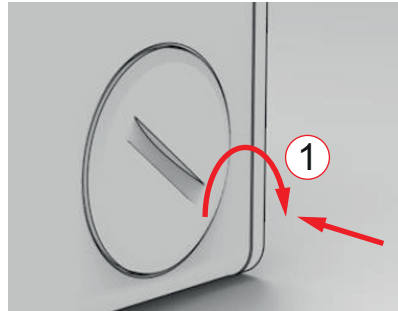

1 Sealing tightly

Once the first battery has been inserted, the WPM Data Holder is ready for operation and transmits once every second.

The WPM Data Holder must be mounted on the same tool as described in 4 "Assembly" and 4.1 "Constructive requirements".

6 OPERATION

6.1 Configuration operation

The WPM Data Holder and WPM Pressure Sensor are configured for PCs using WPM configuration software.

The WPM configuration software has its own set of instructions.

A WPM Data Holder must be assigned to a tool and configured using the WPM configuration software.



It is not possible to operate WPM monitoring without configuration.

The Data Holder has the following basic settings when not configured:

Measurement cycle:	1 second (battery voltage)
BT LE transmission cycle:	1 second

NOTICE

No data during parameterisation

During programming, the data holder does not transmit any current data

► Monitoring interrupted

6.2 Normal operating modes

The WPM Data Holder has three normal operating modes in addition to the configuration operating mode.

6.2.1 Normal operation

In normal operation and without changes to the configuration, the WPM Data Holder transmits once a second (basic setting).

The WPM Data Holder does not go into sleep mode and cyclically transmits statuses and tool information.

6.2.2 Tool check

If the “Check” key on the front side of the WPM Data Holder is pressed, the operating mode of the WPM Data Holder changes from transmitter to receiver.

The WPM Data Holder switches to check mode for a maximum of 60 seconds. In the process, it receives status information for all associated WPM Pressure Sensors and evaluates them. During this time, the gateway LED flashes green.

If the WPM Data Holder is not configured, when this is done, the red and green lights flash in quick succession for about 2 seconds. If not all WPM Pressure Sensors have reported within 60 seconds, the check is terminated and the LED shines red steadily.

If all statuses of all WPM Pressure Sensors are in order, the green LED immediately shines steadily.

If at least one WPM Pressure Sensor issues a warning, the LED flashes red. If there is an error (alarm) from at least one WPM Pressure Sensor, the LED shines red steadily at the end of the 60-second check cycle.

If a sensor is not found, the red LED shines red steadily at the end of the 60-second check cycle.

If there is a sensor warning and a sensor is not found, the red LED flashes at the end of the 60-second check cycle and then shines steadily when it is complete.

The check function ends immediately when all sensors have been detected and are OK or when 60 seconds are up and all above statuses have been displayed.

The WPM Data Holder then switches back to normal operation.

The process can be terminated if the “Check” key is pressed again.

6.2.3 Pairing confirmation for WPM Gateway

If a WPM system is equipped with a WPM Gateway, the login button serves as manual confirmation.

The WPM Gateway is manually set to pairing mode. In this operating mode, the WPM Gateway waits for the WPM Data Holder confirmation triggered by the key being pressed.

The procedure is as follows:

- 1) Activation of the inlet for pairing mode on the WPM Gateway.
- 2) Pressing the “Login” button on the WPM Data Holder – a pressing tool (WPM Data Holder) pairing confirmation is sent to the WPM Gateway.
 - The red LED flashes.
- 3) If the WPM Gateway has received the confirmation signal, the WPM Gateway sends a confirmation to the WPM Data Holder.
 - The green login LED on the WPM Data Holder shines briefly.
- 4) The WPM Gateway searches for all associated configured sensors in parallel and activates them. The gateway displays the corresponding status.
- 5) The WPM Gateway activates the WPM Data Holder; the green login LED shines briefly.
- 6) The WPM Gateway then monitors the pressing tool assigned to the selected WPM Data Holder.
- 7) If the WPM Gateway does not send a confirmation to the WPM Data Holder within 60 seconds, the pairing procedure terminates.
 - The red LED shines steadily.

6.3 Operating mode battery empty

The WPM Data Holder transmits a battery warning signal when the battery starts to get weak.

When the required continuous operating voltage is undercut, the transmission cycle switches to 10 seconds.

The battery warning signal remains static and cannot be reset. The WPM Data Holder is in deep sleep mode.

The WPM Gateway can still monitor a WPM Data Holder in this state and display the battery warning. Reactivating in active mode is not possible.

When exchanging the battery, the device must rest for 3 minutes without battery before a new battery is inserted.

7 MAINTENANCE

The actual data holder requires no maintenance.

The batteries must be replaced.

7.1 Changing the lithium metal battery

The battery must be changed depending on the self-diagnosis of the WPM device.

The values can be checked using the WPM configuration software and can be called up using status information in the Gateway.

To loosen the battery plug, the locking catch on the plug connector needs to be unlocked. This can be done using the tip of a pen, and the plug must be pulled at the same time.

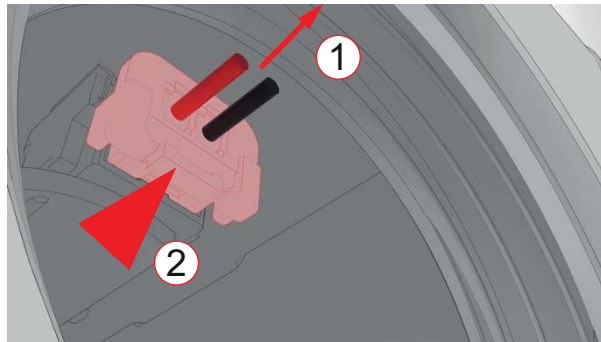

- 1 Pull lightly on the strand
- 2 Loosen the snap-in latch by pressing on it

NOTICE

Maintenance with lithium metal battery

Lithium is a hazardous material. There is a risk of fire.

- ▶ Do not create a short circuit.
- ▶ Do not mechanically damage the battery.
- ▶ Do not recharge the battery.
- ▶ Let the WPM devices rest for 3 minutes without battery before a new battery is inserted.

8 DISPOSAL

The product is an industrial product and is reclaimed through the old industrial device disposal system.

8.1 Disposing of the battery

NOTICE

Dispose of the battery properly

The battery consists of lithium metal cells. Lithium is a valuable raw material and a hazardous material. Improper disposal may cause environmental damage and may be prosecuted.

- ▶ The battery must be removed from the device.
 - ▶ The battery must be disposed of according to the pertinent, customary national and regional laws and guidelines.
 - ▶ The local regulations on proper waste recovery or removal must be complied with.
-

9 INDEXES

9.1 Third-party products

The product contains no components from third-party companies.

9.2 Index of tables

Tab. 1-1	Definition of terms	7
Tab. 1-2	Qualifications of personnel	8

11 INDEX

A

Atmosphere, explosive 5

B

Bluetooth 4 10 10

C

Change 6

Copyright 2 7

D

Dangers

possible 9

Definition of terms 7

Disclaimer of liability 6

E

Environmental damage 18

G

Guidelines 18

I

Injuries

preventing 9

M

Maintenance requirements 4

Measurement cycle 15

Misuse 5

O

Old device disposal system 18

operate WPM monitoring 15

Operator 7

P

pairing mode 16

Personnel

instructed 8 8

qualifications 8

qualified experts 8 8

trained 8 8

S

Safety information 4

Safety notices 9

Signal bar 9

Signal word 9

T

Target group 7

Transmission cycle 15

U

Use

intended 5

proper 4

Users 7

W

WPM configuration software 10

WPM device 17

WPM Gateway 10 12 16

WPM pressure monitoring system 10

WPM Pressure Sensor 10 15

WPM Pressure Sensors 12 13 15

WPM System 16

WPM system 4

More information at

www.fibro.de/downloads-springs-gas-springs/



FIBRO GMBH

Business Area Standard Parts
August-Läpple-Weg
74855 Hassmersheim
Germany
T +49 6266 73-0
info@fibro.de
www.fibro.com

THE LÄPPLE GROUP

LÄPPLE AUTOMOTIVE
FIBRO
FIBRO LÄPPLE TECHNOLOGY
LÄPPLE AUS- UND WEITERBILDUNG