

INSTRUCTIONS MANUAL

NITROGEN COMPACT BOOSTER

2480.00.32.71

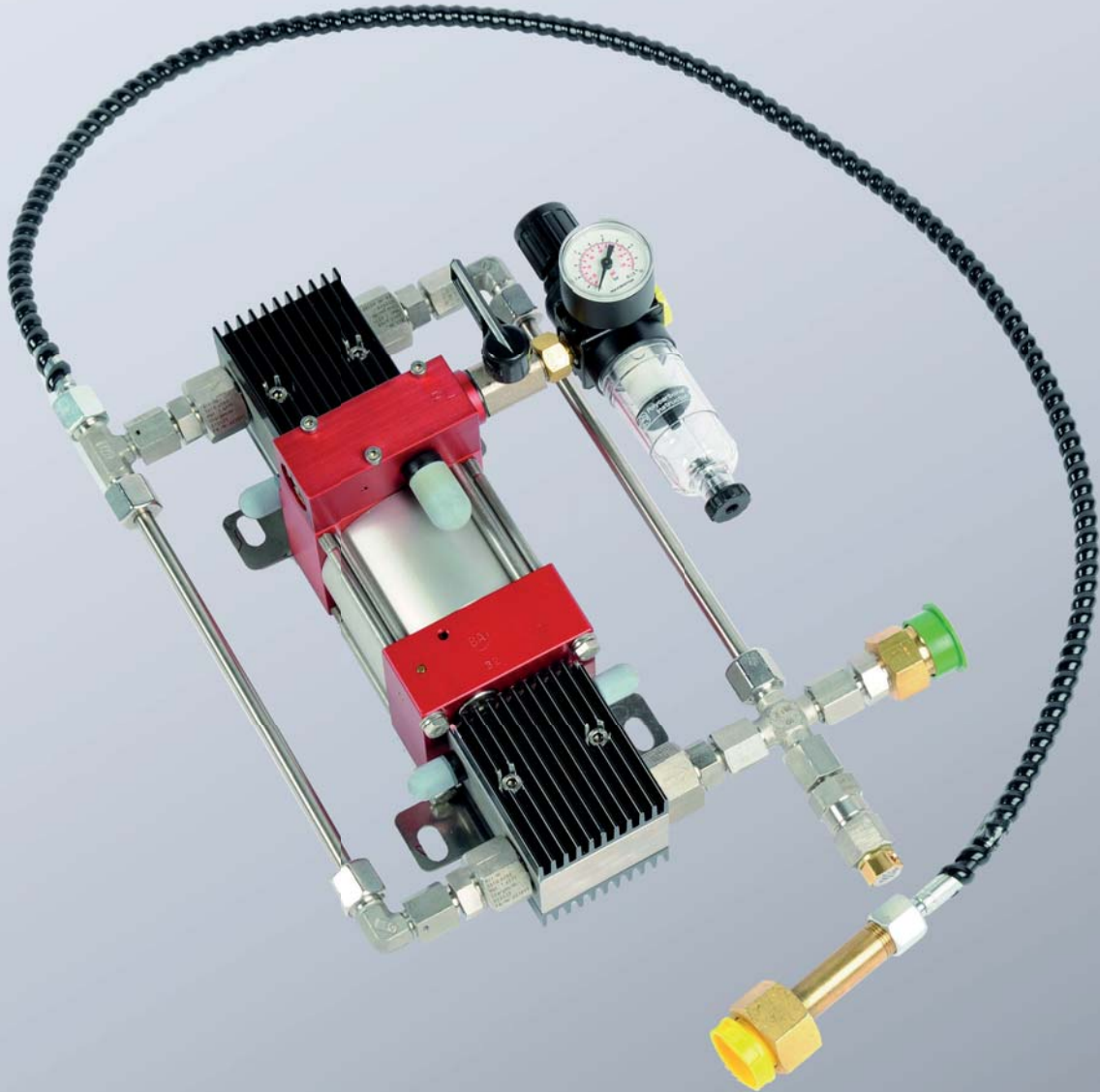

Document: Instructions manual

Document number: 2.7528.05.0621.0100000

Revision: R06-2021

Version: V05

Language:



In the German language, this document is the original version in the EU language of the manufacturer and is labelled with the German national flag.

In the language of a country of use, this document is a translation of the original version and labelled with the national flag of the country of use.

This document is referred to as "instructions" in the following text.

Number of pages in this manual including the title page: 38

These instructions are valid for the product

2480.00.32.71

Nitrogen Compact Booster

This document was created by

FIBRO GMBH

August-Läpple-Weg

DE 74855 Hassmersheim

Phone: +49 (0) 62 66 73 0

Fax: +49 (0) 62 66 73 237

E-mail: info@fibro.de

Internet: www.fibro.de

© All rights to this document are subject to copyright of the author.

Without the prior written permission of FIBRO GMBH, this document must not be copied or reproduced, either in full or in part.

The instructions are intended only for the operator of the described machine only and must therefore not be made available to uninvolved third parties - in particular to competitors.

Contents

1	Introduction	5
1.1	Definition	5
1.2	Intended use	5
1.3	Incorrect application	5
1.4	EC declaration of conformity	6
1.5	Further applicable documents	6
1.6	Set-up	7
1.7	Function	9
1.8	Warranty	9
1.9	Manual	10
1.9.1	Legend	10
1.9.2	Figures	10
1.9.3	Safety instructions	11
1.9.4	General instructions	11
2	Safety	12
2.1	Basic safety instructions	12
2.1.1	Due diligence of the operator	13
2.1.2	Personnel requirements	14
2.2	Residual risks	14
3	Technical data	15
3.1	General technical data	15
3.1.1	Type plate	16
4	Transport	17
4.1	Packaging and weight	17
4.2	Transport damage	17
4.3	Interim storage	17
4.4	Return shipping	17
4.5	Disposing of the packaging material	17
5	Assembly	18
5.1	Important safety instructions	18
5.2	Assembly requirements	18
5.3	Assembling the machine	19
6	Operation	21
6.1	Important safety instructions	21
6.2	Workstations for operating personnel	21
6.3	Prior to commissioning	21
6.4	Operating the machine	22
6.4.1	Settings prior to the operation	22
6.4.2	Fill gas spring	23
7	Faults	26
7.1	Important safety instructions	26
7.2	Customer services	26

8	Servicing	27
8.1	Important safety instructions	27
8.2	Maintenance work	27
8.3	Inspection	27
8.3.1	Prior to each use	27
8.4	Maintenance	28
8.4.1	If necessary	28
8.4.2	Half-yearly	28
8.5	Repair	28
9	Decommissioning	29
9.1	Important safety instructions	29
9.2	Temporary decommissioning	29
9.3	Final decommissioning	29
10	Disassembly and disposal	30
10.1	Important safety instructions	30
10.2	Disassembly	30
10.3	Disposal	30
10.3.1	Disposal of components	30
11	Service and spare parts	31
11.1	Service	31
11.2	Spare parts	31
11.3	Spare parts ordering	32
12	Indexes	33
12.1	Third-party products	33
12.2	Index of figures	33
12.3	Index	34
13	Appendix	35
13.1	Pneumatic plan	35
13.2	Personal notes	36

1 INTRODUCTION

1.1 Definition

The Nitrogen Compact Booster product is a machine in terms of 2006/42/EC, section 1a and 2a.

1.2 Intended use

This machine is intended to compress the nitrogen flowing into a nitrogen bottle in order to fill gas springs. The machine may only be used to compress nitrogen. The machine may only be used to fill gas springs.

The intended use also includes

- reading of these instructions and.
- the adherence of safety information.
- the adherence of all applicable documents.
- adherence to the maintenance regulation.

The machine may only be used as intended. Only processes and handling may be used as described in these instructions.

1.3 Incorrect application

Any use which goes beyond the intended use of the machine and therefore classed as misuse and not allowed.

The machine may not be stressed beyond its limits.

The machine is not suitable for

- the compression of other gases.
- filling of other components.
- the operation with impermissible changes or alterations (see chapter 6.4 "Operating the machine" on page 22).

For all damage to persons or property which has been caused by improper use, the liability lies with the operator of the machine described in this document.

1.4 EC declaration of conformity

All machines have a EU declaration of conformity when supplied as per the directive 2006/42/EG (machine directive). The excerpt of the text in this EU declaration says:

EU declaration of conformity as per directive 2006/42/EG, annex II A (machinedirective)

Manufacturer

FIBRO GMBH
August-Läpple-Weg
DE 74855 Hassmersheim

declares herewith that the machine
Nitrogen Compact Booster

that the models introduced to the market correspond to all relevant regulations of directive 2006/42/EG.

The machine also corresponds to all relevant regulations of further directives applied to the machine.

Applied harmonised standards:

DIN EN ISO 12100:2010 Safety of machinery - General principles for design - Risk assessment and risk reduction (ISO 12100:2010)

Authorised for the compilation of the Technical Documentation is:

FIBRO GMBH August-Läpple-Weg DE 74855 Hassmersheim

1.5 Further applicable documents

In addition to these instructions for the safe handling of the machine further, with applicable documents are necessary.

The information in these documents have to be adhered to.

- EU declaration of conformity as per directive 2006/42/EG
- Pneumatic plan

1.6 Set-up

The illustration shows a schematic diagram of the principal set-up of the machine

The machine consists of:

1	Compressor
2	Start-up valve
3	Filter- and control valve compressed air
4	Nitrogen outlet (labelled with B)
5	Pressure relief valve
6	Nitrogen inlet via bottle hose (labelled with A)

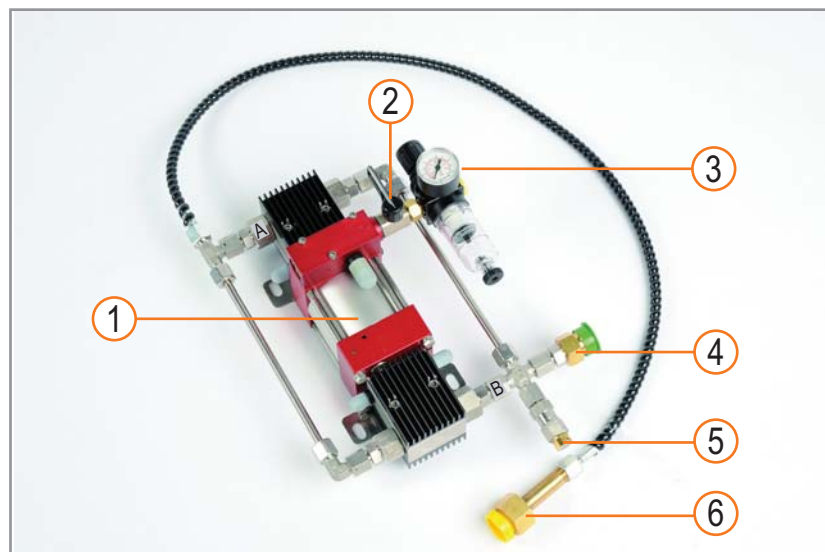

Fig. 1-1 Set-up

To fill a gas spring a filling hose, a filling adapter and a filling and control fitting is required.

The parts can be ordered from FIBRO GMBH using the indicated order number.

a	Filling and control fitting	Order number	2480.00.32.21
b	Filling adapter M6	Order number	2480.00.32.10
	Filling adapter G1/8"	Order number	2480.00.32.11
c	Filling hose	Order number	2480.00.31.02

To fill a gas spring safely we recommend the use of optionally available optional additional equipment.

The parts can be ordered from FIBRO GMBH using the indicated order number.

d	Connection adapter	Order number	2480.00.32.07.04
e	Bottle pressure regulator	Order number	2480.00.32.07.01
f	Gas bottle connection	Order number	2480.00.32.07.02

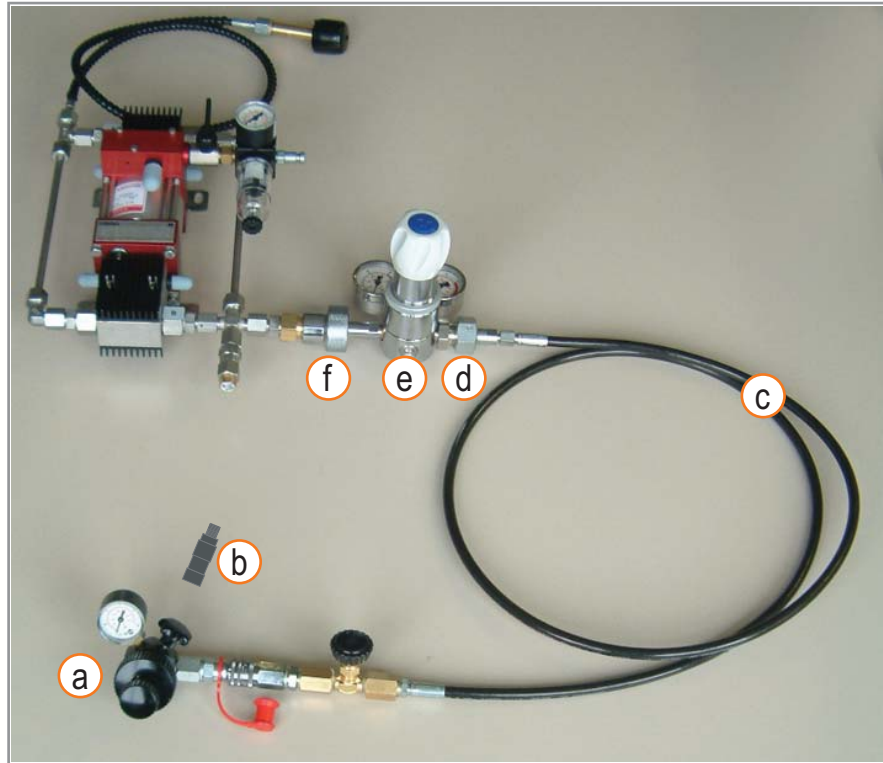

Fig. 1-2 Optional additional equipment

The filling and control fitting (a) is connected via the filling adapter (b) to the filling inlet of the gas spring.

The filling hose (c) creates the connection between nitrogen outlet of the machine and the filling and control fitting.

The bottle pressure regulator (e) can be connected between filling hose and nitrogen outlet.

For the assembly a connection adapter (d) for the filling hose and a gas bottle adaptor (f) to connect the nitrogen outlet.

At the bottle pressure regulator a maximum permissible filling pressure gas spring can be adjusted. Permanent monitoring of the filling process is not required. A gas spring is protected against overfilling.

With the retaining plate the machine can be adjusted securely to the nitrogen bottle.

1.7 Function

The filling of a gas spring directly from a nitrogen bottle only works if the pressure in the bottle is higher than the required filling pressure of the gas spring.

The filling of a gas spring with 150 bar is not possible with a bottle pressure of 120 bar. The remaining nitrogen in the bottle remains unused or has to be used for other applications.

By using the nitrogen compact booster the entire volume of a nitrogen bottle can be used up to the residual pressure of approx. 30 bar.

The machine works according to the principle of a pressure intensifier. The low inlet pressure of a nitrogen bottle is increased by continuous and constant piston motion. A high pressure is available at the outlet of the gas spring.

If using a bottle pressure regulator between nitrogen outlet and filling hose a maximum permissible filling pressure can be set.

The machine is powered with pressurised air. The operating pressure is adjustable.

1.8 Warranty

The guarantee is regulated contractually (see Terms and Conditions or contract)

1.9 Manual

These instructions describe the handling of the machine and contain important information about its intended use.

A copy of these instructions must be stored and made continuously available at the operating site of the machine, and everyone assigned to work on or with the machine must read, understand and apply them.

The safety information in the individual chapters must be observed.

These instructions and the other applicable documents are not subject to any modification service.

We reserve the right to update data and drawings in these instructions based on continuing technical development.

The respectively current version can be requested from FIBRO GMBH.

1.9.1 Legend

Characters, symbols and abbreviations are used in these instructions in order to clearly represent the content. They have the following meaning:

- 1) Marks the first level of an itemisation
 - a) Marks the second level of an itemisation
- Marks the first level of a list
 - Marks the second level of a list
- ✓ Contains information on requirements which have to be fulfilled before executing handling instructions.
- ✂ Contains information on tools, operating materials or tools required for the execution of repair work.



The book symbol before a text is a reference to a related document or another chapter of these instructions. The content of this document or the chapter must be taken into account.



The information symbol before a text marks a supplementary note or an important application tip.

1.9.2 Figures

The figures in these instructions are examples. Deviations between a figure and the actual conditions on the machine are possible.

The drawings of FIBRO GMBH and the information on third-party products are decisive.

1.9.3 Safety instructions

These instructions contain safety notices intended to draw attention to possible dangers that should be observed to prevent injury.

The pertinent text describes

- the type of danger
- the source of danger
- the options for preventing injuries
- the consequences in case of non-observance of the warning notices

The safety instructions are emphasised by a colour signal bar with warning triangle and signal word.

The signal bars have the following meaning:

 **DANGER!**

A safety notice on a red signal bar with the signal word DANGER designates a hazard with a high risk level which, if not avoided, will result in death or severe injury.

 **WARNING!**

A safety notice on an orange signal bar with the signal word WARNING designates a hazard with a medium risk level which, if not avoided, might result in death or severe injury.

 **CAUTION!**

A safety notice on a yellow signal bar with the signal word CAUTION designates a hazard with a low risk level which, if not avoided, could result in minor or moderate injury.

1.9.4 General instructions

In addition to the safety notices, these instructions contain information that must be observed to prevent property damage.

The pertinent text describes

- the possible reason for property damage
- the possibilities for preventing property damage

Notices of possible property damage are emphasised by a blue signal bar and the signal word *ATTENTION*.

NOTICE

Notices for the prevention of property damage are not related to possible injuries.

2 SAFETY

2.1 Basic safety instructions

Most accidents when handling technical equipment occur due to disregarding the basic safety regulation.

Noticing a potential danger can prevent accidents from happening. If dangers are present, then safety information on the machine and in this document will provide a warning. If warnings are not adhered to then it may lead to personal injury or death.

FIBRO GMBH can not foresee all potential situations which may potentially causes. The warnings in this document and on the machine are therefore not all encompassing.

Staff has to have the required training and experience as well as the necessary tools in order to carry out work on the machine correctly.

Improper operation, warning or repair can be dangerous and cause severe injury or death.

No work for transport, assembly, maintenance or repair must be carried out if the information about transport, assembly, maintenance or repair has not been read and understood.

The machine may not be used in any different way as described in these instructions. All safety regulations and protection measures at the installation location applicable to the use have to be adhered to including location specific regulation and workplace safety measures.

If a work material, an act, a work method or work technique is used which has not been specifically suggested by FIBRO GMBH, then the user has to ensure the safety for himself and other persons.

He also has to ensure that the machine is not damaged or rendered unsafe by carrying out the work for operation, maintenance and repair.

The information, descriptions and illustrations in this documents are based on the information on the basis of information which was available at the point of creation of this document.

These and other points can change at any point. The changes can have an influence on the machine properties. Prior to starting any work, obtain the currently available information.

2.1.1 Due diligence of the operator

This machine is designed and constructed according to state-of-the-art. The requirements for maintaining the safety and health protection were met.

This safety can in the operational practice only be achieved if all measures required for this purpose are put into place. The operator of the machine has to plan these measures and check their execution.

The operator has to ensure that

- the machine is only used as intended.
- the machine is only be operated in impeccable, functional state.
- a copy of these instructions and all applicable documents are available in a legible condition and complete at the installation location of the machine It has to be ensured that all persons who have to carry out work on this machine can check these instructions at any time.
- only specifically trained and authorised staff can operate, maintain and repair the machine.
- staff knows the instructions and the containing safety instructions.
- the responsibility of staff during operation and maintenance has to be clearly determined and adhered to.
- the staff is regularly instructed in all applicable topics of work safety and environmental protection.
- Operating instructions for work safety have to be issued.
- national accident prevention and in-house regulations are observed.
- if required personal safety clothing is available.

2.1.2 Personnel requirements

The following safety instructions must be observed in all operations on the machine. Disregarding the safety instructions can lead to serious injuries or even death.

Personnel must have the necessary training and experience and possess the necessary tools in order to be able to perform the work on the machine correctly. Improperly performed work can be dangerous and cause serious or fatal injuries.

Do not perform any work if you have not read and understood the information in these instructions and in the applicable documentation.

If work equipment, operation, work methods or work techniques that have not been explicitly proposed by FIBRO GMBH are used, the operator must himself ensure the safety for himself and for other persons.

It must be ensured that the machine is also not damaged or does not become unsafe over the course of the intended work.

All persons working on and with the machine must

- have read and understood these instructions.
- observe the safety information and guidelines in the operating instructions and the instructions contained therein.
- observe the danger signs attached to the machine and the instructions on them.
- observe the warning information about possible residual risks.
- make sure that there are no unauthorised persons in the vicinity of the machine.
- in addition to the operating instructions, observe also the operating instructions for occupational health and safety and accident prevention issued by the operator.
- inform the operator or the supervisory personnel about any malfunctions.
- inform the respective managers immediately about any changes to the machine which can affect its safety.

2.2 Residual risks

WARNING!

High pressure

The machine is designed for an inlet pressure up to 200 bar.

- ▶ Connection only to N₂-nitrogen bottle up to 200 bar.

WARNING!

Unauthorised modifications

Any unauthorised modifications or any mounting of additional equipment not approved by FIBRO GMBH compromise the operational safety.

- ▶ Conversions or unauthorised modifications are prohibited.
- ▶ The mounting of additional equipment must be discussed with FIBRO GMBH.
- ▶ Unauthorised modifications endanger the safe operation and may lead to serious or fatal injuries.

3 TECHNICAL DATA

3.1 General technical data

Name	Value
Inlet pressure	30 - 200 bar
Compressed driving air	minimum 1 bar to 6 bar maximum Pressurised air purified and oiled
Calculated operating pressure (at 6 bar air drive pressure)	192 bar (+ Residual bottle pressure)
Pressure relief	400 bar
Transmission	1 : 32
Piston displacement	11,6 cm ³
Medium supply performance*	280 NL/min
*The feed performance is depending on the air drive pressure and from the inlet pressure.	
Max. operating temperature	60 °C
Weight	approx. 7,2 kg
Dimensions (WxDXH)	160x380x345 mm
Noise emission	< legally permissible peaks
Connections	
Pressurized air	G 1/4"
Nitrogen inlet	Hose line DN4, length 1 m for N2-bottles 200 bar
Nitrogen outlet	Bottle connection W 24,32 x 1 1/4" for N2-bottles 200 bar

3.1.1 Type plate



A type plate is fitted on the machine. Please state the information on the type plate for all questions or on all orders.

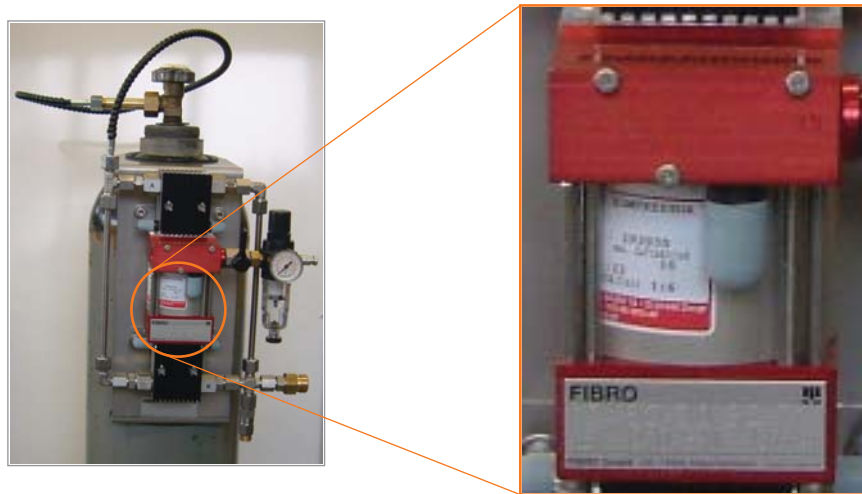

Fig. 3-1 Type plate

4 TRANSPORT

4.1 Packaging and weight

The machine is packaged into a box for shipping. The weight of the entire packaging unit is 6 kg.

4.2 Transport damage

On delivery, the consignment must be checked immediately to ensure that it is complete and has not been damaged in transit. If damage is found on the packaging that indicates possible damage to the contents, the contents must also be inspected for damage.

If damage is found, the transport company must be informed immediately and the transport company must verify the damage.

4.3 Interim storage

- Only store when dry, in its original packaging and in enclosed rooms
- Storage temperature +5...+40 °C
- Maximum humidity 60% (at 25 °C).
- No aggressive substances may be stored in the storage room (acids, bases, solvents etc.).

4.4 Return shipping

For the returns the parts which have to be sent back to the manufacturer for repair have to be packaged securely.

4.5 Disposing of the packaging material

The packaging materials must be either reused or properly disposed of in accordance with the country-specific regulations.

5 ASSEMBLY

5.1 Important safety instructions

 **WARNING!**

Faulty assembly

Connection to not authorised nitrogen bottle or false connection of additional equipment is dangerous.

Only qualified staff may carry out assembly work. Please adhere to the operating or assembly instruction of additional equipment.

For the assembly of the machine or of the additional equipment, please ensure that only

- ▶ authorised persons stay in the work area and that no other persons are endangered by the assembly work.

5.2 Assembly requirements

In order to use the machine properly at least the following parts have to be fitted:

- customer specific pressurised air adapter
- Filling hose
- Filling and control fitting



To securely fill a gas spring, we recommend additionally the use of the following optionally available additional equipment:

- Bottle pressure regulator

Prior to assembly those parts and suitable tools have to be available to tighten the connections.

5.3 Assembling the machine

WARNING!

High pressure

Unsuitable tools may fail. This means that nitrogen can escape under high pressure.

- ▶ Only use additional equipment such as filling and control fitting, filling hose and bottle pressure regulator. Risk of injury



The following description considers the assembly of all required parts and all possible additional equipment.

1. Hang the machine over the connection of the nitrogen bottle.
2. Bottle hose to be connected.
 - a) Remove yellow protective cap.
 - b) Connect the connection screws of the bottle hose to the nitrogen bottle. ATTENTION left-handed thread
 - c) Tighten the nut with a spanner.
3. Pressurised air adapter to be screwed into the pressurised air inlet.
 - a) pressurised air inlet at the filter and control valve, thread G 1/4".
 - b) Remove yellow protective cap.
 - c) Screw company specific pressurised air adapter with seal into the pressurised air inlet.

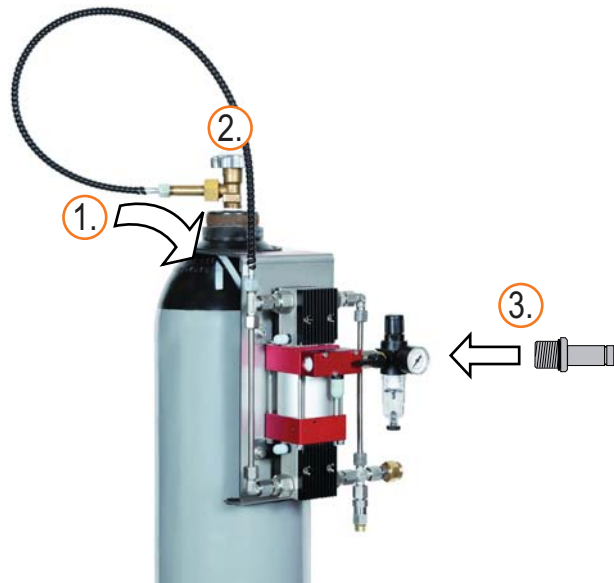

4. Bottle pressure regulator to be assembled.
 - a) Remove green protective cap.
 - b) Bottle pressure regulator to be screwed at the nitrogen outlet thread.
 - c) Tighten the nut with a spanner.
5. Filling hose to be assembled.
 - a) Filling hose to be screwed on to the bottle pressure regulator.
 - b) Tighten the nut with a spanner.
6. Filling and control fitting to be assembled.
 - a) Insert the bayonet plug of the Filling and control fitting into the bayonet coupling of the filling hose.

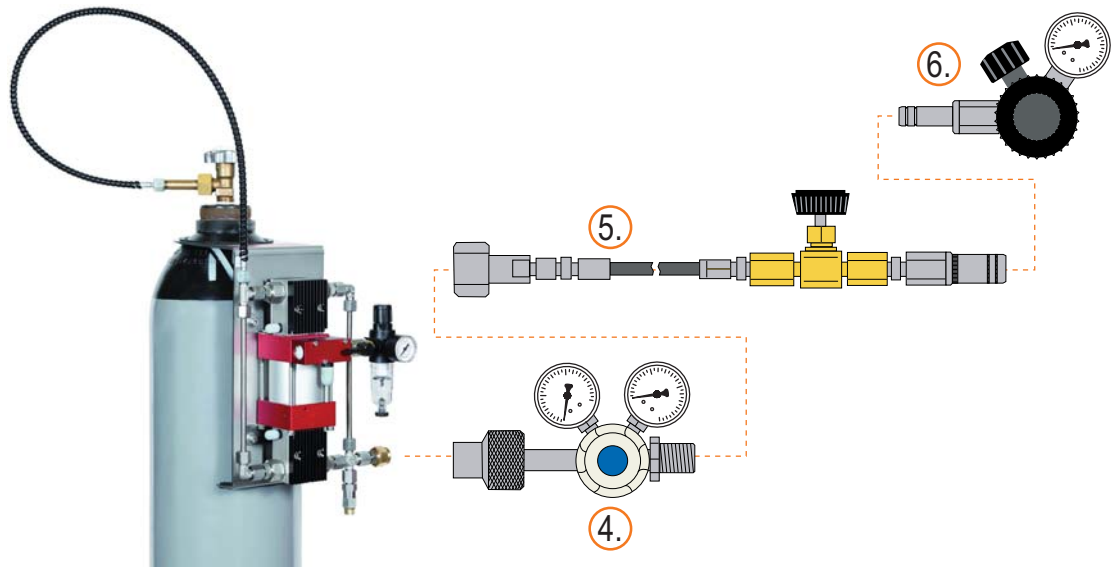

7. Provide pressurised air supply.
 - a) Pressurised air hose of the customer-side pressurised air supply on the pressurised air adapter.

6 OPERATION

6.1 Important safety instructions

 **WARNING!**

Impermissible values and setting.

The permissible maximum values for the operation of the machine which may not be exceeded.

- ▶ Operation only on nitrogen bottle with maximum 200 bar internal pressure.
- ▶ Compressed driving air maximum 6 bar.
- ▶ Check values and settings prior to commissioning.
- ▶ Nitrogen exits at the over pressure valve. Risk of injury.

Please ensure when operating the machine that the

- machine is ready assembled. (see chapter 5.3 "Assembling the machine" on page 19).
- operating staff has been informed about the proper conduct in the event of a machine failure.
- machine is only operated by staff that has been trained, instructed and authorised to do so. These persons have to know the instructions and act accordingly.
- machine is only operated according to its intended use (see chapter 1.2 "Intended use" on page 5).
- operating instructions of the operator are adhered to.

6.2 Workstations for operating personnel

The workplace to operate is directly at the machine. Operational parts are the startup valve at the control bottle pressure regulator and the control at the filter and control valve.

6.3 Prior to commissioning

A visual inspection has to be carried out prior to commissioning the machine. The following has to be checked and ensured:

- there is no damage to the machine.
- that the pressurised air supply is connected and operational.
- that the machine is connected to a nitrogen bottle.
- the valve of the nitrogen bottle is connected.
- that the start-up valve of the machine is connected.

6.4 Operating the machine

NOTICE

Damage to the machine

If the controls are set incorrectly, parts of the machine may be damaged.

- ▶ Prior to opening of the nitrogen bottle the drive air pressure has to be adjusted and the valve at the bottle pressure regulator has to be closed.
- ▶ Over pressure can occur in the machine if the drive air pressure is too high.
- ▶ If the valve is open then a pin in the bottle pressure regulator can be damaged.

The following description is applicable to the operation with all required parts and all possible additional equipment.

6.4.1 Settings prior to the operation

1. Drive air pressure has to be set.
 - a) Turning knob (a) at the filter and control valve has to be pulled up.
 - b) By turning the knob, set the air pressure to a maximum of 6 bar (right = pressure increase, left = pressure reduction)
 - c) Turning knob (a) at the filter and control valve has to be pushed down.
2. Close the valve of the bottle pressure regulator.
 - a) Turn turning knob (b) at the bottle pressure regulator until it arrests.

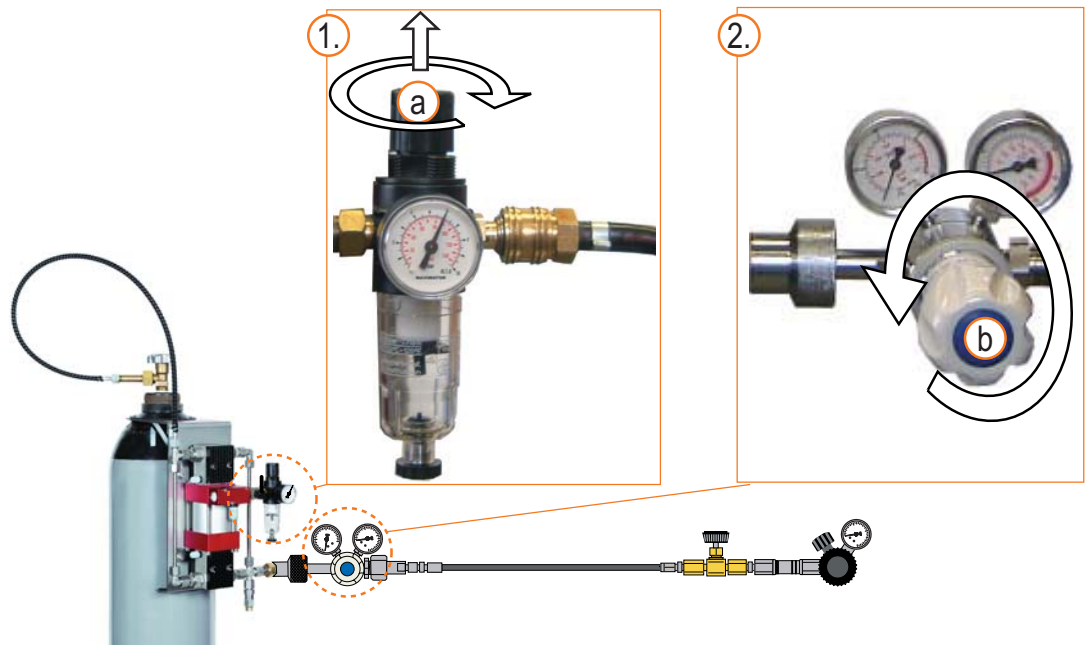
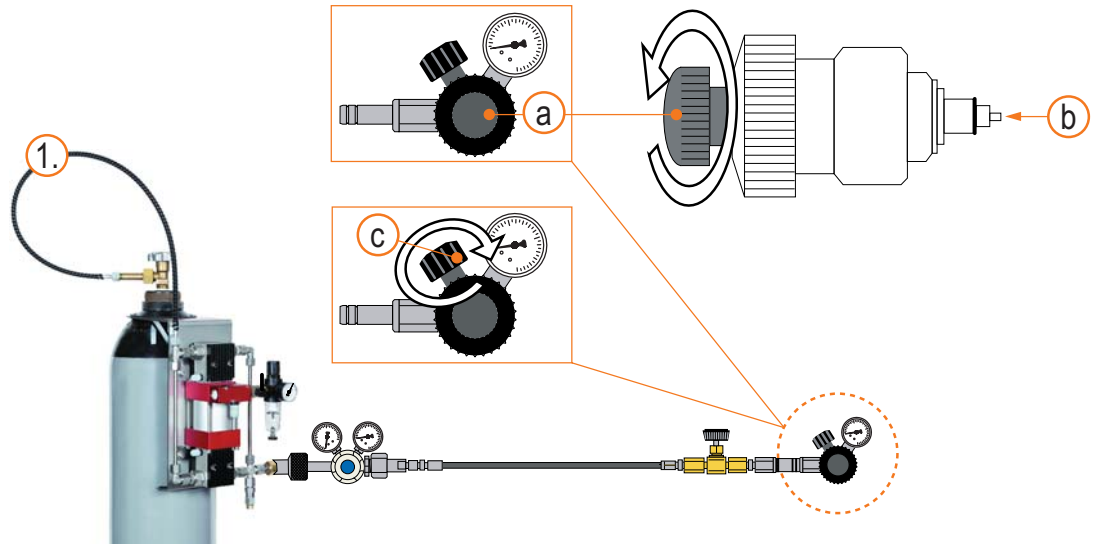

Fig. 6-1 Settings prior to the operation

6.4.2 Fill gas spring

1. Filling and control fitting to be prepared.
 - a) Small turn knob (a) to be turned left until it arrests. This moves the tripping pin (b) into the retracted position.
 - b) Outlet valve (c) to be connected.



2. Remove the blanking plug above the filling opening of the gas spring with an Allen key (M6 - 3 mm; G1/8" - 5 mm).
3. Unscrew and remove set screw.
4. Filling adapter to be screwed into the filling opening of the gas spring. Tighten hand-tight.
5. Filling and control fitting to be put on the filling adapter. Screw on the large turn knob by turning it.

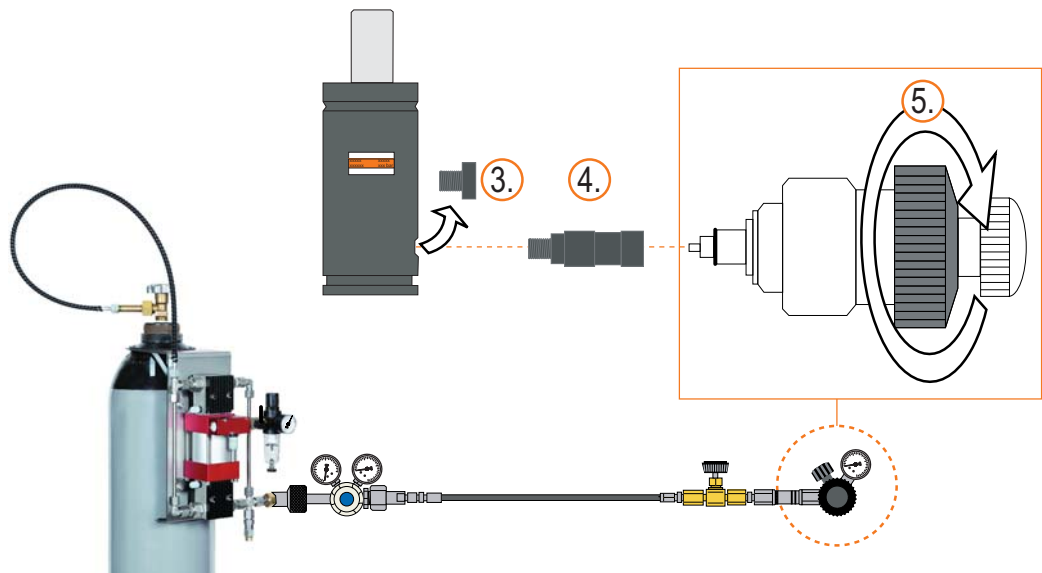

6. Shut-off valve has to be closed at the filling hose.
7. Nitrogen bottle has to be opened at the turn knob of the bottle valve.
8. Switch on machine (switch on lever has to be turned left by 90°).
9. Adjust at the bottle pressure regulator the maximum filling pressure (right = pressure increase, left = pressure reduction).

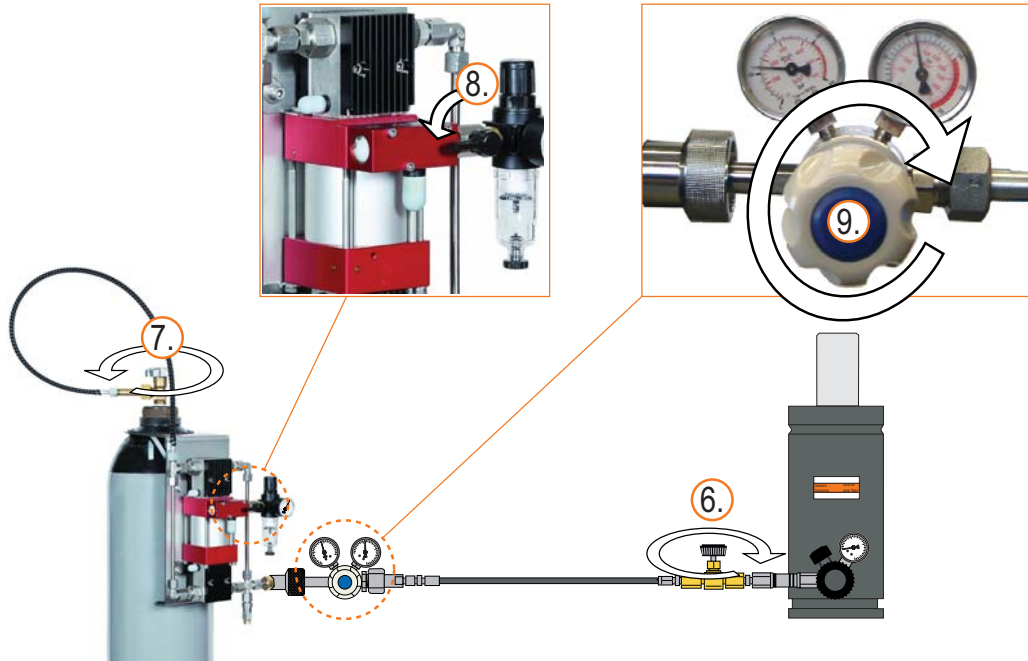

NOTICE

Damage to the valve in the gas pressure spring

- ▶ Slowly open the shut-off valve on the filling hose.
- ▶ Carefully allow nitrogen to flow in.

10. Shut-off valve has to be opened slowly at the filling hose.
 - a) The right manometer at the bottle pressure regulator and the manometer at the filling and control fitting show the actual pressure in the gas spring.



The permissible filling pressure (a) is imprinted on the gas spring.

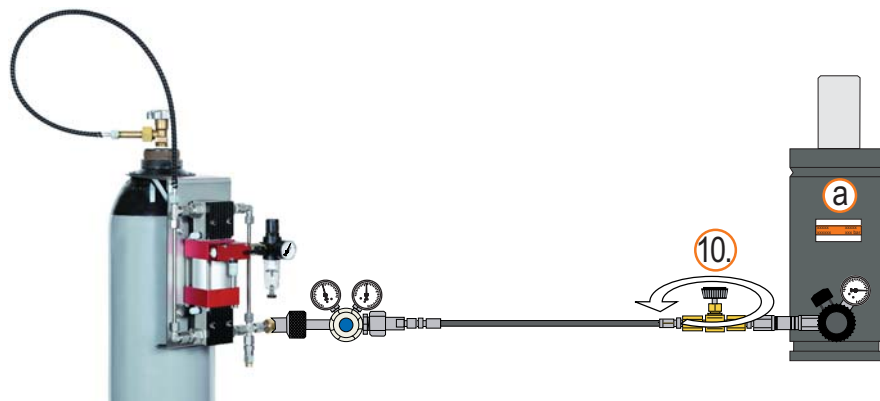

11. After filling the nitrogen bottle has to be closed at the turn knob of the bottle valve.
12. Switch off machine (switch on lever has to be turned right by 90°).
13. Discharge valve has to be opened at the filling and control fitting.
 - a) Pressure and remaining nitrogen escape from the filling and control fitting and filling hose.

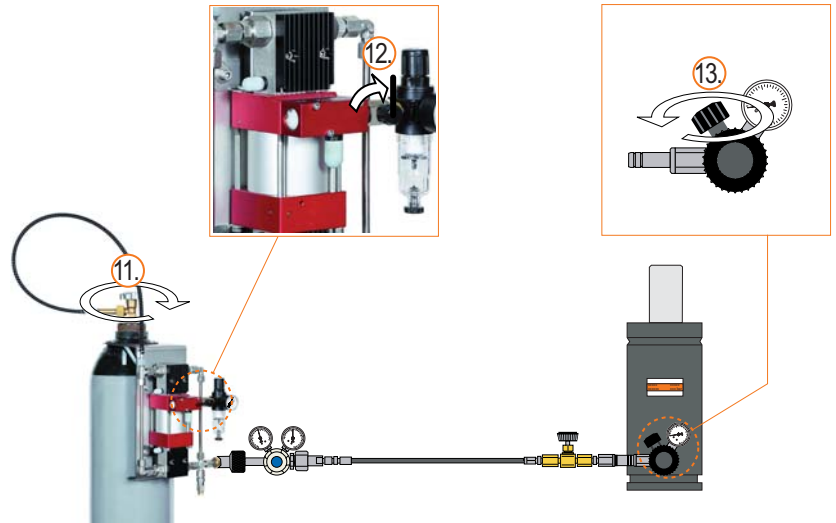

14. Unscrew filling and control fitting by turning the large turning knob from the filling adapter.
15. Filling adapter to be unscrewed.

 **WARNING!**

Nitrogen escaping

Never bend over the valve of the gas pressure spring.

- ▶ Wear safety goggles.

16. Check if nitrogen escape from the valve of the gas spring.
17. Set screw to be inserted into filling opening of the gas spring. Tighten with a torque of 15-18 Nm.



The set screw has a sealing function and has always to be assembled.

7 FAULTS

7.1 Important safety instructions

 **WARNING!**

Non-authorized staff

Staff which hasn't been trained accordingly has not the necessary authorities, to find faults or to remove faults.

- ▶ Faults may only be removed by FIBRO customer service or by staff of the operator which has been trained and authorised to carry out these activities.
- ▶ Before removing the faults, the machine has to be separated from the nitrogen bottle and the pressurised air supply.
- ▶ If using non-authorized staff, wrong action may cause injuries.

7.2 Customer services

If you should require the assistance of our customer service we would ask you to provide the following information:

- Serial number from type plate FIBRO GMBH (see chapter 3.1.1 "Type plate" on page 16)
- Description of the current fault
- Time and circumstances of fault
- Suspected cause

You can reach our customer service Monday to Friday from (times are UTC + 1) 7 am to 5 pm on **service number** +49 (0) 62 66 73 0

Outside of the stated time, there is an automatic message with further information.

Customer service address:

FIBRO GMBH
August-Läpple-Weg
DE 74855 Hassmersheim

info@fibro.de

On www.fibro.de you can find all FIBRO subsidiaries worldwide.

8 SERVICING

8.1 Important safety instructions



WARNING!

Non-authorized staff

Only the work described in these instructions with regards to the maintenance may be carried out by the staff of the operator.

- ▶ This staff has to be trained and authorised for the intended tasks.
- ▶ All further work and repairs may as a rule only be carried out by FIBRO staff.
- ▶ If using non-authorized staff, wrong action may cause injuries.

8.2 Maintenance work

The following tasks are considered maintenance work:

- Inspection
- Maintenance / cleaning
- Repair

8.3 Inspection

8.3.1 Prior to each use

- Control of the essential functional units.
- Control the filter bowl at the filter and control valve for accumulated condensate.
 - Release the condensate if necessary.
- Control the cleanliness.
 - Clean machine if necessary.

8.4 Maintenance



WARNING!

Switch machine off safely

Working while the machine is switched on is dangerous.

- ▶ Before maintenance, the machine has to be separated from the nitrogen bottle and the pressurised air supply.
- ▶ Maintenance work may only be carried out when the machine is switched off and unpressurised.
- ▶ Injuries if the machine is switched on.

8.4.1 If necessary

8.4.1.1 Filter in filter and control valve has to be exchanged



If the filter in the filter and control valve is of a dark colour it has to be exchanged.

1. Unscrew sight glass.
2. Take off old filter.
3. Insert new filter.
4. Screw in sight glass.

8.4.2 Half-yearly

- Check the compressor for leaks.



We recommend general maintenance of the device by FIBRO GMBH every 1000 operating hours, 2,000,000 strokes or 18 months.

8.5 Repair

The operator should not carry out repair work on the machine.

If repair measures are necessary, then FIBRO GMBH's customer service has to be notified.

9 DECOMMISSIONING

9.1 Important safety instructions

 **WARNING!**

High pressure

Exiting pressure at the inlets can cause unexpected start-up if the machine is accidentally switched on.

- ▶ Before decommissioning, the machine has to be separated from the nitrogen bottle and the pressurised air supply.
- ▶ The energy supply recovery can lead to injuries.

 **WARNING!**

Non-authorized staff

Staff which hasn't been trained accordingly has not the necessary authorities, to carry out decommissioning.

- ▶ Decommissioning may only be carried out by trained staff, which has been authorised for to carry out the tasks.
- ▶ If using non-authorized staff, wrong action may cause injuries.

9.2 Temporary decommissioning

For decommissioning over a longer period:

- Switch of machine properly
- Bottle hose to be disconnected from the nitrogen bottle.
- Pressurised air hose to be taken off.
- Machine is fitted with information which states clearly that it is decommissioned temporarily.

9.3 Final decommissioning

For final decommissioning and shut down:

- Switch of machine properly
- Bottle hose to be disconnected from the nitrogen bottle.
- Pressurised air hose to be taken off.
- Remove the machine from the nitrogen bottle.
- Machine is fitted with information which states clearly that it is decommissioned for good.

10 DISASSEMBLY AND DISPOSAL

10.1 Important safety instructions

 **WARNING!**

High pressure

Exiting pressure at the inlets can cause unexpected start-up if the machine is accidentally switched on.

- ▶ Before decommissioning, the machine has to be separated from the nitrogen bottle and the pressurised air supply.
- ▶ The energy supply recovery can lead to injuries.

10.2 Disassembly

- Decommission and shut down machine for good before disassembly (see chapter 9.3 "Final decommissioning" on page 29).
- Filter and control valve, bottle hose and pipes have to be unscrewed.

10.3 Disposal

10.3.1 Disposal of components

NOTICE

Dispose of assemblies correctly!

Incorrect disposal of assemblies can cause environmental damage and lead to prosecution.

- ▶ In any case, the assemblies must be disposed of in accordance with the relevant national and regional laws and guidelines.
- ▶ Care must be taken to ensure the environmentally-friendly disposal of the process materials.
- ▶ Local regulations for the correct recycling and disposal of waste must be adhered to.

Information about waste disposal sites and collecting point can be obtained from the local administration.

The machine consists of:

- Iron / steel
- Aluminium
- Brass
- Plastic

11 SERVICE AND SPARE PARTS

11.1 Service

You can reach our customer service Monday to Friday from (times are UTC + 1) 7 am to 5 pm on **service number** +49 (0) 62 66 73 0

Outside of the stated time, there is an automatic message with further information.

Written enquiries to:

FIBRO GMBH
August-Läpple-Weg
DE 74855 Hassmersheim

info@fibro.de

On www.fibro.de you can find all FIBRO subsidiaries worldwide.

11.2 Spare parts

Spare parts must meet the technical requirements specified by FIBRO GMBH.

By ordering original spare parts from FIBRO GMBH, you are assured that these requirements will be met.

FIBRO GMBH can assume no liability for any damage caused as a result of using non-original spare parts.

11.3 Spare parts ordering

Bei der Bestellung von Ersatzteilen bitten wir um folgende Angaben:

- Name, address, mailing address
- Exact name of the machine Serial number from type plate(see chapter 3.1.1 "Type plate" on page 16)
- Exact name of the spare part
 - If necessary, provide samples, photos or sketches
- Number of required spare parts

Please send your spare parts order to

FIBRO GMBH

August-Läpple-Weg

DE 74855 Hassmersheim

info@fibro.de

On www.fibro.de you can find all FIBRO subsidiaries worldwide.

On receipt of the spare parts delivery:

- Number, correctness and condition of the supplied parts
- Please feedback any errors immediately

Claims for compensation due to transport damage have to be made immediately.

12 INDEXES

12.1 Third-party products

The product contains no components from third-party companies.

12.2 Index of figures

Fig. 1-1	Set-up	7
Fig. 1-2	Optional additional equipment	8
Fig. 3-1	Type plate	16
Fig. 6-1	Settings prior to the operation	22

12.3 Index

A

Additional equipment 18
Assemblies 30

B

Bottle hose 7 29 30
Bottle pressure regulator 8 8 9 18 21 24
Bottle valve 24 25

C

Changes
 impermissible 5
 technical 10
 unauthorised 14
Compressed driving air 15 21
Connection adapter 8 8
conversions
 impermissible 14
Copyright 2

D

Damage 21
 to the contents 17
 to the packaging 17
Danger sign 14
Dangers
 possible 11
Directive 2006/42/EG 6
Discharge valve 25
Documents
 applicable 10
 with applicable 6

E

EU declaration of conformity 6

F

Filling adapter 7 8 23 25
Filling and control fitting 7 8 18 20 23 25
Filling hose 7 7 9 18 20 24 25
Filling inlet 8
Filling pressure 24
 permissible 8 9 24
Filter and control valve 7 21 27 28 30

G

Gas bottle adaptor 8
Gas bottle connection 8
Gas spring 5 7 9 18 23

H

Humidity
 maximum 17

I

Injuries
 preventing 11
Inlet pressure 15

Intended use 5

M

Misuse 5
modifications
 impermissible 14
 unauthorised 14

N

Nitrogen 5 9 21 24 25
Nitrogen bottle 5 9 18 19 21 24 25 26 28 29
Nitrogen compact booster 9

O

Optional additional equipment 8
Outlet valve 23

P

Packaging material 17
Pressure relief valve 7
Pressurised air adapter 18
Pressurised air hose 20 29
Pressurised air inlet 19
Pressurised air supply 20 21 26 28 29 30

R

Repair 17
Returns 17

S

Safety notices 11
Signal bar 11
Signal word 11
Start-up valve 21
Storage temperature 17
Switch off 28

T

Tools 14
Transport damage 17

U

Use
 intended 10

W

Workplace 21

More information at

www.fibro.de/en/downloads-springs-gas-springs/



FIBRO GMBH

Business Area Standard Parts
August-Läpple-Weg
74855 Hassmersheim
Germany
T +49 6266 73-0
info@fibro.de
www.fibro.com

THE LÄPPLE GROUP

LÄPPLE AUTOMOTIVE
FIBRO
FIBRO LÄPPLE TECHNOLOGY
LÄPPLE AUS- UND WEITERBILDUNG