

OPERATING INSTRUCTIONS FOR GAS SPRINGS

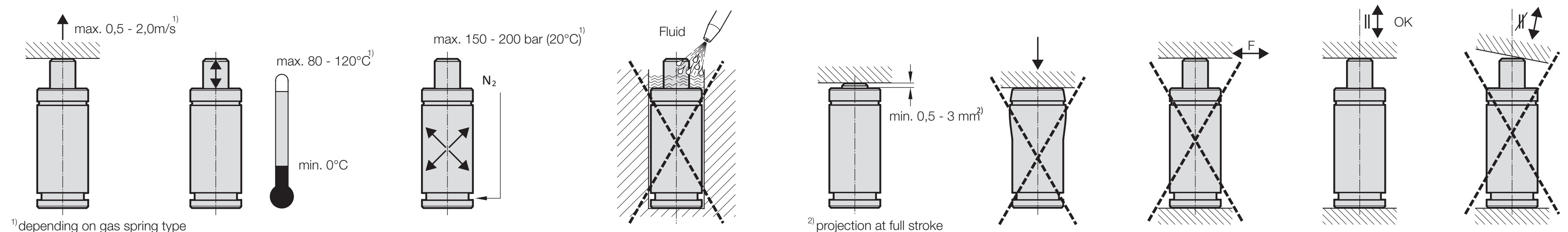

MOUNTING INSTRUCTIONS

To achieve the best possible service life and safety from the gas spring, the instructions below must be followed. The gas spring is intended for use in tool and machine applications.



- Before inserting the gas springs, check the corresponding filling pressure.
- Secure the gas spring to the tool/machine whenever possible, using the threaded hole(s) in the base of the gas spring or a suitable flange.
- The threaded hole in the piston rod top should not be used for mounting purposes. It is only to be used when servicing the gas spring.
- Do not use the gas spring in such a way that the piston rod is realised freely from its compressed position, as this could cause internal damage to the gas spring.
- Make sure the gas spring is mounted parallel to the direction of the compression stroke.
- Ensure the contact surface of the piston rod top is perpendicular to the direction of the compression stroke and is sufficiently hardened.
- The gas spring should not be subjected to the side loads.
- Protect the piston rod against mechanical damage and contact with fluids.
- We recommend providing a lifting reserve of 10% of the nominal stroke length or 5 mm.
- The maximum charging pressure (at 20 °C) must not be exceeded as it may effect the safety of the product.
- Exceeding the gas spring's recommended operating temperature will shorten the service life of the gas spring.
- The entire contact surface of the piston rod / piston should be used.
- Do not remove the adapter base plate 2480.00./2497.00.20. from spring until all gas pressure has been discharged.

MOUNTING EXAMPLES

Examples of gas spring installation options are shown below.

See the FIBRO standard parts catalogue, gas springs chapter for further information on installation.

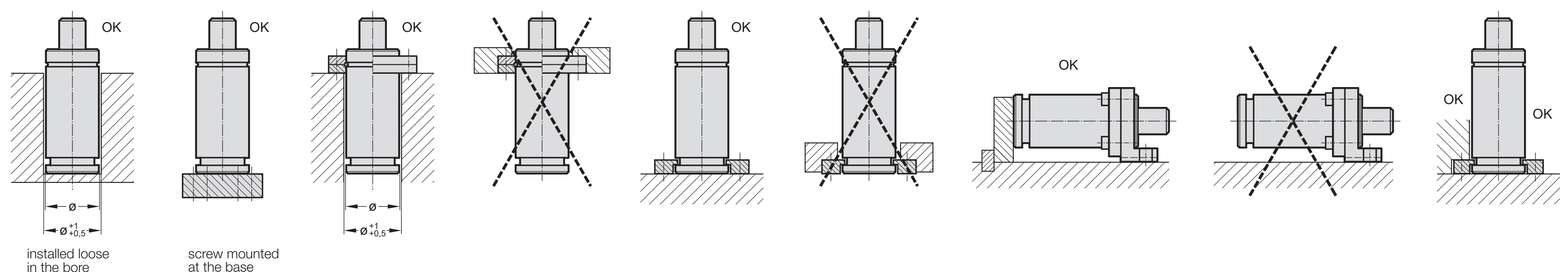

SERVICE INFORMATION

If correctly installed and used, the following minimum gas spring service-intervals can be expected. Stroke lengths up to and including 50 mm – 1 million strokes. Stroke lengths above 50 mm – 100'000 stroke metres. We recommend the gas spring to be replaced after 2 million strokes.

The gas springs are fully serviceable¹⁾. To service a gas spring, repair kits and tool kits are available.

Service instructions are included with every repair kit. Gas springs must be checked for secure fitting every time there is maintenance work.

¹⁾ Non-repairable springs, see FIBRO standard parts main catalogue, gas springs chapter.

NOTE!

For the safe handling of gas springs and other nitrogen products, the safety regulations must be observed. Maintenance work on the product may only be done, if nitrogen gas is no longer contained in the gas spring.

Only specially trained personnel with a good knowledge of the products should service the gas spring. Mistakes made during assembly and charging may infringe on safety and/or detrimentally effect the service life of the gas spring. Do not modify the product in any way.

FIBRO is not liable if fittings that are not original FIBRO fittings or fastening, accessory, and attachment parts that are not released by FIBRO are used.

Further information is available from your contractual partner or FIBRO GmbH, Standard Parts Division.

BASIC INFORMATION

(exact values for the individual gas spring types can be found in the FIBRO standard parts main catalogue)

Pressure medium Nitrogen N₂

Gas filling pressure 25 – 150 bar at 20 °C

Force increase by temp. ±0,3%/°C

Working temperature 0 °C – +80 °C

Max. allowable piston rod velocity 1.6 m/s