

A DIE SETS



B PRECISION GROUND PLATES AND FLAT BARS



C LIFTING AND CLAMPING DEVICES



D GUIDE ELEMENTS



E GROUND PRECISION COMPONENTS



Punches and matrixes, ball-lock punches, retainers, pins, gauge pins



F SPRINGS



G ELASTOMERS



H FIBRO-CHEMICAL TOOLING AIDS



J PERIPHERAL EQUIPMENT



K CAM UNITS



L STANDARD PARTS FOR MOULD MAKING



GROUND PRECISION COMPONENTS

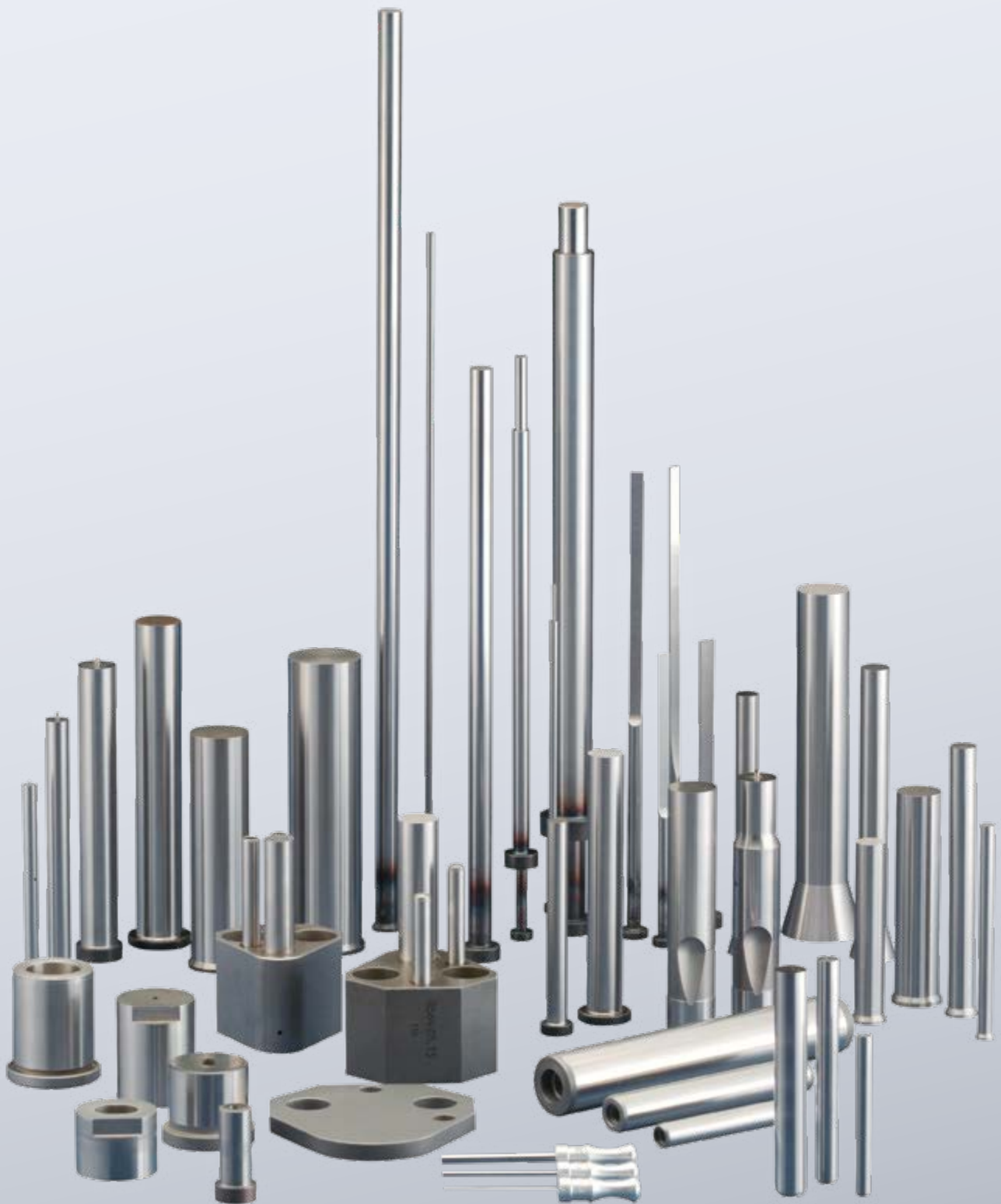

GROUND PRECISION COMPONENTS

FIBRO Precision Components cover a very wide range of materials, shapes and sizes and thus permit virtually unrestricted selection even to highly individual requirements.

The continuous inventory of our standardised ground precision parts at home and abroad runs into seven figures. We are sure that the part you need is among them. Stock shortfalls are quickly bridged from current series production.

Batch production in our interpretation not only spells prompt delivery but also exceptional quality. Starting with the arrival inspection of raw materials, every single manufacturing operation on FIBRO Precision Components is followed by a quality check.

Lastly, an uncompromising final inspection of each and every part guarantees that the trade mark FIBRO is and remains synonymous with Quality.

We reserve the right to make changes, as technology is subject to change due to new findings and further developments.

The correct ratio of sheet material/tool material is decisive for the cutting edge life of the active cutting

elements (punch, cutting insert) and therefore for the tool costs and quality of the workpieces.













We would like to point out that the effort put into construction and product engineering is only beneficial if the position – brand to cutting insert – can be maintained during the operation by correct tool guidance.

The wide range of materials listed for our cutting elements is intended to provide you with guidance.

Diagrams on the relationships between the compressive strength, flexural strength and hardness of the three most important tool materials should help you choose.

Our experienced tooling specialists will assist you with further detailed information.

CONTENTS

	E17		2229.	E27
	Comparative graphs		Punch, stepped, square, ~ DIN 9861	
	E18-19		2239.	E28
	Ground precision parts – materials and coatings		Punch, stepped, rectangular, ~DIN 9861	
	E20		2249.	E29
	Sintered Hard Metal HIP-densified		Punch, stepped, slot, ~ DIN 9861	
	E21-37		2259.	E30
	Punches ~ DIN 9861		Punch, stepped, rectangle with radiused corners, ~DIN 9861	
	222.	E22	224.	E32
Punch DIN 9861 Shape DA			Punch DIN 9861 Shape CA	
	223.	E23	225.	E33
Punch DIN 9861 Shape D / ISO 6752			Punch DIN 9861 Shape C	
	2209.	E25	274.	E34
Punch, blank, DIN 9861, Shape D			Punch similar to DIN 9861 Shape CA	
	2219.	E26	275.	E35
Punch, stepped, round, ~DIN 9861			Punch similar to DIN 9861 Shape C	

CONTENTS



272. **E36**

Punch similar to DIN 9861, Shape D

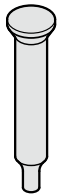

273. **E37**

Punch similar to DIN 9861, Shape C

E39-41

Punches with tapered head 30°

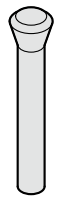

2281. **E40**

Punch with tapered head 30°, Shape D

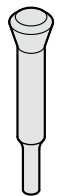

2291. **E41**

Punch with tapered head 30°, Shape C

E43-50

Punches with tapered head

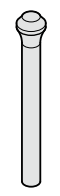

2284.3. **E44**

Punch with tapered head, DIN 5118 Shape A

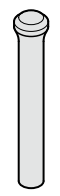

2206. **E45**

Punch with tapered head, blank, DIN 5118 Shape A



2216. **E46**

Punch with tapered head, stepped, round, ~DIN 5118 Shape B

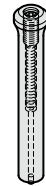

2706. **E47**

Punch with tapered head, blank, with ejector pin, DIN 5118 Shape E



2716. **E48**

Punch with tapered head, stepped, round, with ejector pin, ~DIN 5118 Shape F



2284.00. **E49**

Piloted counterbore for tapered-head punch

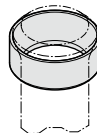

2284.00.01. **E50**

Mounting ring for punch with tapered head

E43-50

Punches with tapered head

Punches DIN 9844

E51-56



220. **E53**

Punch DIN 9844, Shape A



221. **E54**

Punch DIN 9844, Shape B

CONTENTS

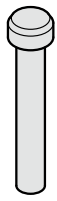

270. **E55**

Punch similar to DIN 9844, Shape A

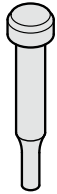

271. **E56**

Punch similar to DIN 9844, Shape B

E57-60

Punches with cylindrical head

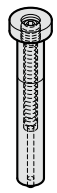

267. **E58**

Punch with ejector pin

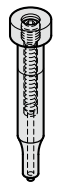

268. **E59**

Punch with ejector pin, stepped, short point

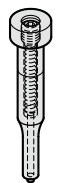

269. **E60**

Punch with ejector pin, stepped, long point

E61-63

Punches square/rectangular

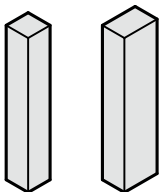

230. **E62**

Punch without head, square / rectangular, Shape A

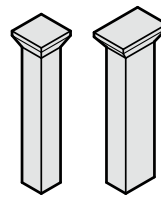

231. **E63**

Punch with head, square / rectangular, Shape B

E65-118

Ball-Lock punches



2202. **E67**

Ball-Lock punch, blank, light duty

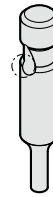

2212. **E68**

Ball-Lock punch, stepped, round, light duty



2222. **E69**

Ball-Lock punch, stepped, square, light duty



2232. **E70**

Ball-Lock punch, stepped, rectangular, light duty



2242. **E71**

Ball-Lock punch, stepped, slot, light duty



2252. **E72**

Ball-Lock punch, stepped, rectangle with radiused corners, light duty

CONTENTS

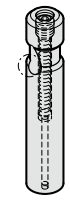

2702. **E73**
Ball-Lock punch, blank, with ejector pin, light duty

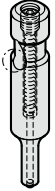

2712. **E74**
Ball-Lock punch, stepped, round, with ejector pin, light duty

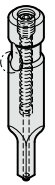

2722. **E75**
Ball-Lock punch, stepped, square, with ejector pin, light duty

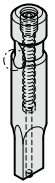

2732. **E76**
Ball-Lock punch, stepped, rectangular, with ejector pin, light duty

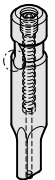

2742. **E77**
Ball-Lock punch, stepped, slot, with ejector pin, light duty

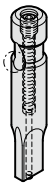

2752. **E78**
Ball-Lock punch, stepped, rectangle with radiussed corners, with ejector pin, light duty

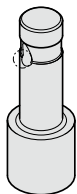

2204. **E79**
Ball-Lock punch, punch larger than shaft, blank, light duty

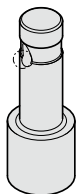

2214. **E80**
Ball-Lock punch, punch larger than shaft, round, light duty

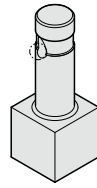

2224. **E81**
Ball-Lock punch, punch larger than shaft, square, light duty

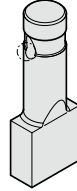

2234. **E82**
Ball-Lock punch, punch larger than shaft, rectangular, light duty



2244. **E83**
Ball-Lock punch, punch larger than shaft, slot, light duty

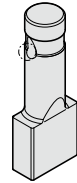

2254. **E84**
Ball-Lock punch, punch larger than shaft, rectangle with radiussed corners, light duty

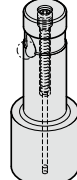

2704. **E85**
Ball-Lock punch, punch larger than shaft, blank, with ejector pin, light duty

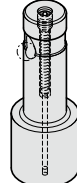

2714. **E86**
Ball-Lock punch, punch larger than shaft, round, with ejector pin, light duty

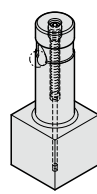

2724. **E87**
Ball-Lock punch, punch larger than shaft, square, with ejector pin, light duty

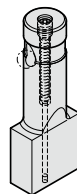

2734. **E88**
Ball-Lock punch, punch larger than shaft, rectangular, with ejector pin, light duty

CONTENTS

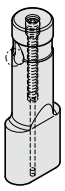

2744. **E89**
Ball-Lock punch, punch larger than shaft, slot, with ejector pin, light duty

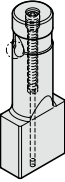

2754. **E90**
Ball-Lock punch, punch larger than shaft, rectangle with radiused corners, with ejector pin, light duty

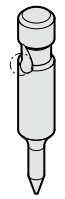

2262. **E91**
Ball-Lock pilot pin, with tapered tip, light duty

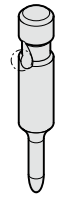

2272. **E92**
Ball-Lock pilot pin, with parabolic tip, light duty

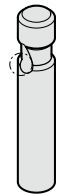

2203. **E93**
Ball-Lock punch, blank, heavy duty

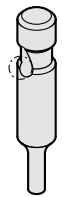

2213. **E94**
Ball-Lock punch, stepped, round, heavy duty

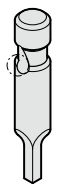

2223. **E95**
Ball-Lock punch, stepped, square, heavy duty

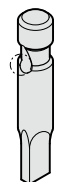

2233. **E96**
Ball-Lock punch, stepped, rectangular, heavy duty



2243. **E97**
Ball-Lock punch, stepped, slot, heavy duty



2253. **E98**
Ball-Lock punch, stepped, rectangle with radiused corners, heavy duty

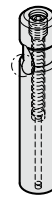

2703. **E99**
Ball-Lock punch, blank, with ejector pin, heavy duty

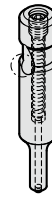

2713. **E100**
Ball-Lock punch, stepped, round, with ejector pin, heavy duty

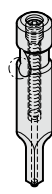

2723. **E101**
Ball-Lock punch, stepped, square, with ejector pin, heavy duty

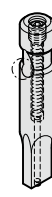

2733. **E102**
Ball-Lock punch, stepped, rectangular, with ejector pin, heavy duty

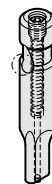



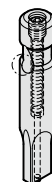



2743. **E103**
Ball-Lock punch, stepped, slot, with ejector pin, heavy duty

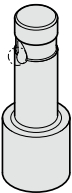
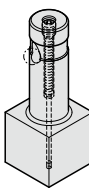
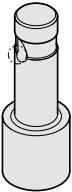
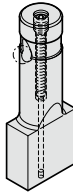
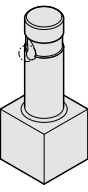
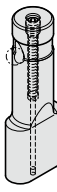
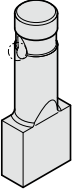
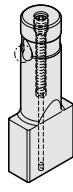
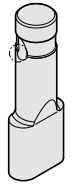

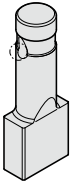

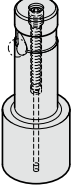
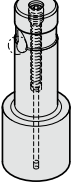





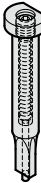

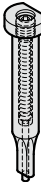

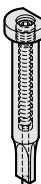
2753. **E104**
Ball-Lock punch, stepped, rectangle with radiused corners, with ejector pin, heavy duty

CONTENTS

	2205. Ball-Lock punch, punch larger than shaft, blank, heavy duty	E105		2725. Ball-Lock punch, punch larger than shaft, square, with ejector pin, heavy duty	E113
	2215. Ball-Lock punch, punch larger than shaft, round, heavy duty	E106		2735. Ball-Lock punch, punch larger than shaft, rectangular, with ejector pin, heavy duty	E114
	2225. Ball-Lock punch, punch larger than shaft, square, heavy duty	E107		2745. Ball-Lock punch, punch larger than shaft, slot, with ejector pin, heavy duty	E115
	2235. Ball-Lock punch, punch larger than shaft, rectangular, heavy duty	E108		2755. Ball-Lock punch, punch larger than shaft, rectangle with radiused corners, with ejector pin, heavy duty	E116
	2245. Ball-Lock punch, punch larger than shaft, slot, heavy duty	E109		2263. Ball-Lock pilot pin, with tapered tip, heavy duty	E117
	2255. Ball-Lock punch, punch larger than shaft, rectangle with radiused corners, heavy duty	E110		2273. Ball-Lock pilot pin, with parabolic tip, heavy duty	E118
	2705. Ball-Lock punch, punch larger than shaft, blank, with ejector pin, heavy duty	E111	E119-134 Punches ISO 8020		
	2715. Ball-Lock punch, punch larger than shaft, round, with ejector pin, heavy duty	E112		2201. Punch, blank, ISO 8020	E121

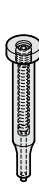
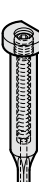
CONTENTS

	2211. Punch, stepped, round, ISO 8020	E122		2731. Punch, stepped, rectangular, with ejector pin, ISO 8020	E130
	2221. Punch, stepped, square, ISO 8020	E123		2741. Punch, stepped, slot, with ejector pin, ISO 8020	E131
	2231. Punch, stepped, rectangular, ISO 8020	E124		2751. Punch, stepped, rectangle with radiused corners, with ejector pin, ISO 8020	E132
	2241. Punch, stepped, slot, ISO 8020	E125		2261. Pilot pin with tapered tip, ISO 8020	E133
	2251. Punch, stepped, rectangle with radiused corners, ISO 8020	E126		2271. Pilot pin with parabolic tip, ISO 8020	E134
	2701. Punch, blank, with ejector pin, ISO 8020	E127	Pilot units		E135-136
	2711. Punch, stepped, round, with ejector pin, ISO 8020	E128			
	2721. Punch, stepped, square, with ejector pin, ISO 8020	E129		2276. Pilot unit to Mercedes-Benz Standard	E136
			Punch guide bushes		E137-139

CONTENTS

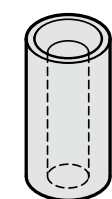

262. **E138**

Guide bush for punch,
DIN 9845 Shape C

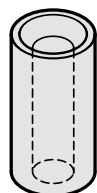

2621. **E139**

Guide bush for punch, ISO 8978

E141-165

Matrixes ISO 8977

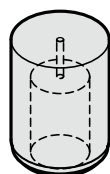

2606. **E143**

Matrix without shoulder, blank,
ISO 8977

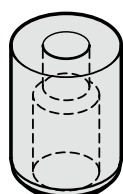

2616. **E144**

Matrix without shoulder, round,
ISO 8977

**E145-153,
E157-165,
E171-179**

Rotation locks

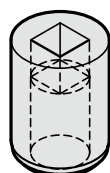

2626. **E146**

Matrix without shoulder, square,
ISO 8977

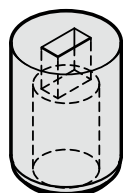

2636. **E148**

Matrix without shoulder, rectangular,
ISO 8977

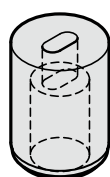

2646. **E150**

Matrix without shoulder, slot,
ISO 8977

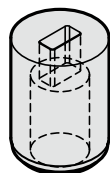

2656. **E152**

Matrix without shoulder, rectangle
with radiussed corners, ISO 8977

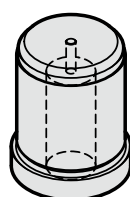

2607. **E155**

Matrix with shoulder, blank, ISO 8977

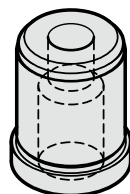

2617. **E156**

Matrix with shoulder, round,
ISO 8977

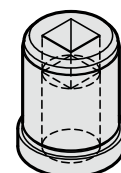

2627. **E158**

Matrix with shoulder, square,
ISO 8977

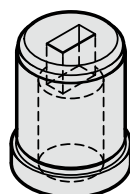

2637. **E160**

Matrix with shoulder, rectangular,
ISO 8977

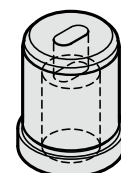

2647. **E162**

Matrix with shoulder, slot, ISO 8977

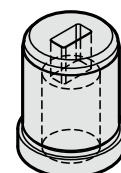

2657. **E164**

Matrix with shoulder, rectangle with
radiussed corners, ISO 8977

CONTENTS

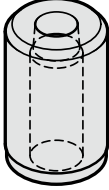
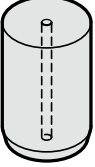
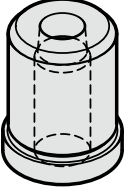
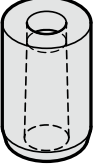
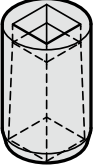
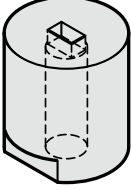
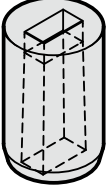
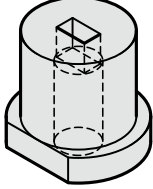
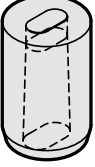
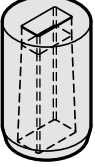
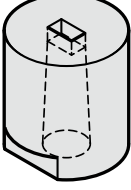
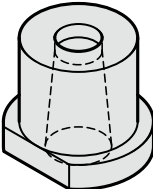
		E167-179				E182
	Matrixes, Automotive Standard				260. Matrix without collar, DIN 9845 Shape A	
	2605. Matrix without shoulder, blank, Automotive Standard	E169			261. Matrix with collar, DIN 9845 Shape B	E183
	2615. Matrix without shoulder, round, Automotive Standard	E170				E185-187
					Matrixes, cylindrical	
	2625. Matrix without shoulder, square, Automotive Standard	E172			2602. Matrix without collar, cylindrical	E186
	2635. Matrix without shoulder, rectangular, Automotive Standard	E174			2612. Matrix with collar, cylindrical	E187
	2645. Matrix without shoulder, slot, Automotive Standard	E176				E189-191
					Matrixes, conical	
	2655. Matrix without shoulder, rectangle with radiused corners, Automotive Standard	E178			2601. Matrix without collar, conical	E190
		E181-183			2611. Matrix with collar, conical	E191
	Matrixes DIN 9845					

CONTENTS

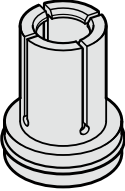
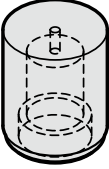
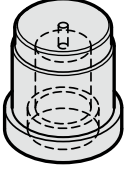
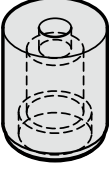
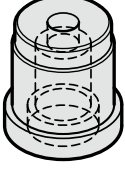
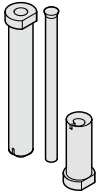
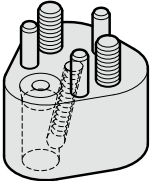
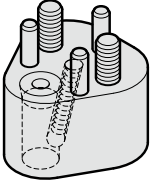
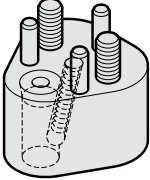
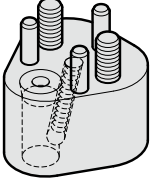
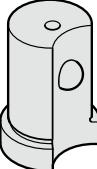
		E193-200			
	Dynamic stripping elements (DAE)				
	2618.	E194-195			
	Dynamic stripping element (DAE)				
	2618.06.	E197			
	Matrix without collar for dynamic stripper (DAE), blank				
	2618.07.	E198			
	Matrix with collar for dynamic stripper (DAE), blank				
	2618.16.	E199			
	Matrix without collar for dynamic stripper (DAE), round				
	2618.17.	E200			
	Matrix with collar for dynamic stripper (DAE), round				
		E201-205			
	Standardised special shapes				
		E207-208			
	Punching and embossing unit				
				2282.01.	E208
				Punching and embossing unit with matrix for punched holes and self tapping screws	
					E209-216
				Triangle retainers for ball-lock punches	
				2664.05.	E210
				Triangle retainer for ball-lock punches, light duty	
				2664.06.	E211
				Triangle retainer for ball-lock punches, heavy duty	
				2664.07.	E212
				Triangle retainer for ball-lock punches, light duty	
				2664.10.	E213
				Triangle retainer for ball-lock punches, heavy duty	
					E214
				Accessories for retainers, triangular, for Ball-Lock punches	
				2668.2.	E215
				ACCU-LOCK Fixture device for ball-lock punches, light duty	

CONTENTS

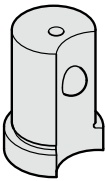
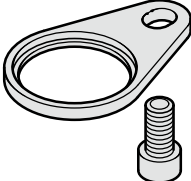
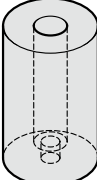
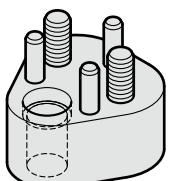
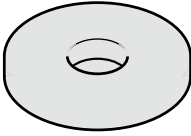
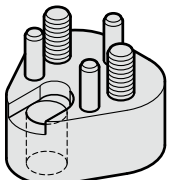
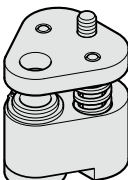
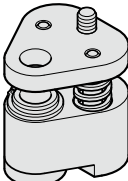
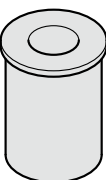
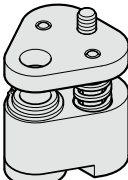
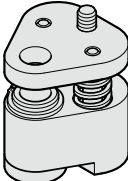
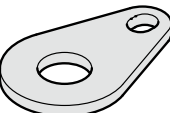
	2668.3. ACCU-LOCK Fixture device for ball-lock punches, heavy duty	E216		2667.2. Stripping unit - Mounting plate	E224
		E217-220		243.7. Elastomer Stripper	E226
	Triangle retainers for punches ISO 8020				
	2664.02. Triangle retainer, for punches ISO 8020 without anti-rotation element	E218		243.7. .1 Washer	E227
	2664.04. Triangle retainer, for punches ISO 8020 with anti-rotation element	E219			E228
		E220		POLY STRIP stripper unit - Order examples	
	Accessories for retainers, triangular, for punches to ISO 8020			2667.iso.0. POLY STRIP stripper unit, with start borehole, for ISO 8020 punch	E229
		E221-240		2667.iso.1. POLY STRIP stripper unit, round, for ISO 8020 punch	E230
	Strippers				
	2431.7. Elastomer Stripper	E222		2667.iso.2. POLY STRIP stripper unit, square, for ISO 8020 punch	E231
		E223		2667.iso.3. POLY STRIP stripper unit, rectangle, for ISO 8020 punch	E232
	2667.1. Stripping unit - Pressure plate				

CONTENTS

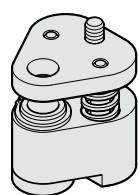

2667.iso.4. **E233**

POLY STRIP stripper unit, slot, for ISO 8020 punch

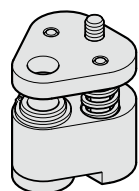

2667.iso.5. **E234**

POLY STRIP stripper unit, rectangle with radius, for ISO 8020 punch

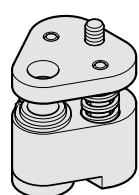

2667.sw.0. **E235**

POLY STRIP stripper unit, with start borehole, for ball-lock punch

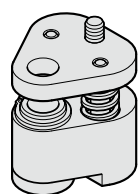

2667.sw.1. **E236**

POLY STRIP stripper unit, round, for ball-lock punch

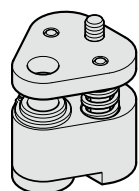

2667.sw.2. **E237**

POLY STRIP stripper unit, square, for ball-lock punch

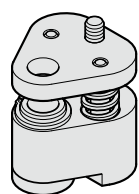

2667.sw.3. **E238**

POLY STRIP stripper unit, rectangle, for ball-lock punch

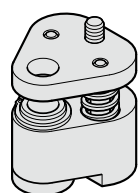

2667.sw.4. **E239**

POLY STRIP stripper unit, slot, for ball-lock punch

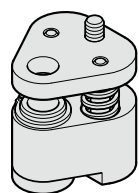

2667.sw.5. **E240**

POLY STRIP stripper unit, square with radius, for ball-lock punch

E241-248

Dowel pins / Liner bushes for dowel pins



235.1. **E242**

Dowel pin similar to DIN EN ISO 8734



2351.1. **E243**

Dowel pin according to DIN EN ISO 8734



236.1. **E244**

Dowel pin with internal extracting thread, similar to DIN EN ISO 8735



2361.1. **E245**

Dowel pin with internal extracting thread, according to DIN EN ISO 8735

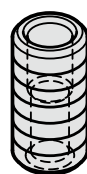

265.1. **E246**

Liner bush for dowel pin, for bonding

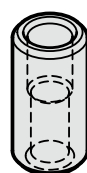



2650.1. **E247**

Liner bush for dowel pin, for push fit

236.001 **E248**

FIBROZIPP

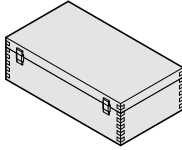
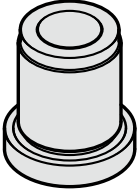
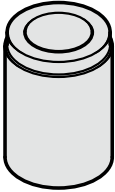
CONTENTS

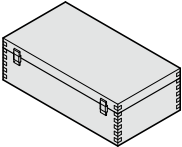
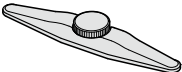
		E249-251		240.9x	E257
	Drill bushes DIN 172/179			Wooden boxes	
	276. Drill bush with collar, DIN 172 Shape A	E250			E258-259
	277. Drill bush without collar, DIN 179 Shape A	E251		Special punches and matrixes to customer's drawings	
		E253-257			
	Gauge pins				
	240.1./2. Gauge pin DIN 2269	E254-255			
	240.11./22. Gauge pin with handle, DIN 2269	E256			
	240.4x/5x Range of check pins in storage box	E257			
	240.45. Gauge Pin Holders	E257			

COMPARATIVE GRAPHS

Compressive strength (0,2 proof stress)

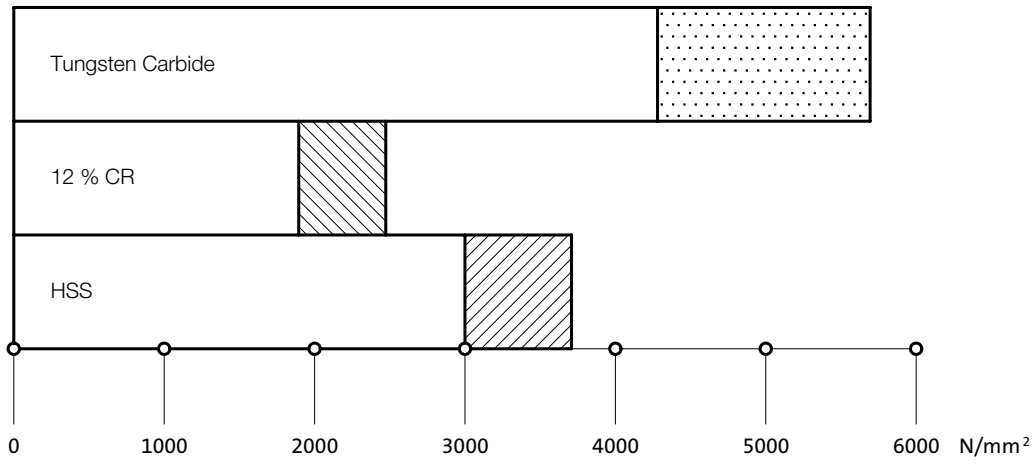

Flexural strength

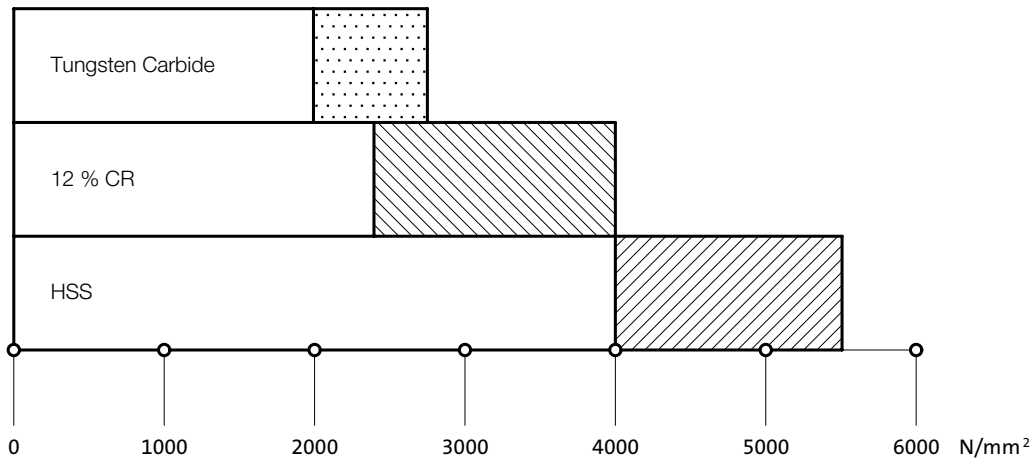

Hardness Vickers

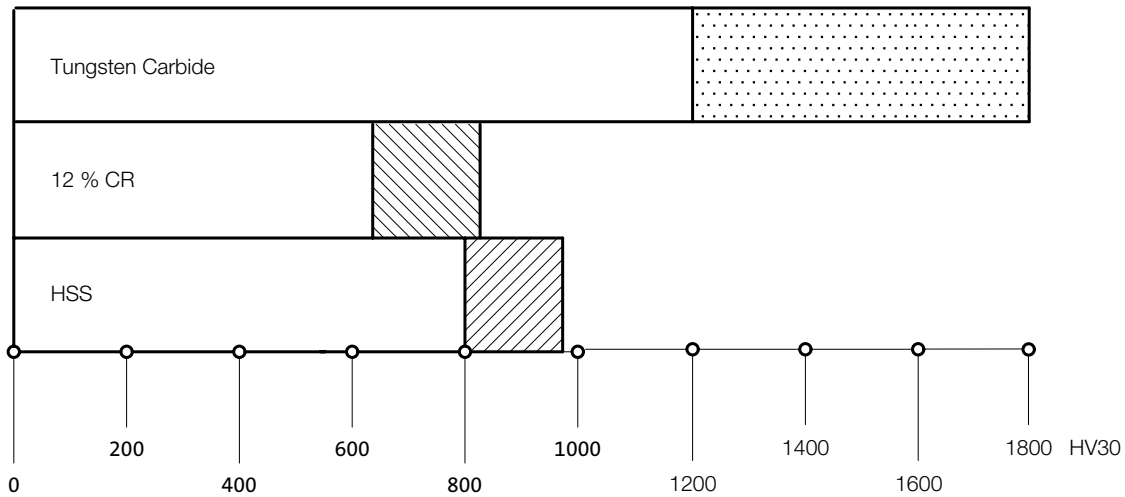

GROUND PRECISION PARTS – MATERIALS AND COATINGS

Carrier material	=	Cold work steel, alloyed (WS)
Characteristics:		Material no.: 1.2210, 1.2067 or similar Cold work steel tools have a hard, wear-resistant surface layer and a relatively tough, lower impact core. Cold work steels can be used at tool temperatures up to approx. 200°C.
		WS = material code = "1"
	e.g.	Order no. = 239.1. ...
Carrier material	=	Cold work steel, high-alloyed, with 12% Cr (HWS)
Characteristics:		Material no: 1.2436, 1.2379 or similar See WS. High chromium content increases resistance to wear and toughness and contributes to resistance to corrosion. Molybdenum increases heat resistance and additionally improves corrosion and resistance to wear.
		HWS = material code = "2"
	e.g.	Order no. = 260.2. ...
Carrier material	=	High-speed steel (HSS)
Characteristics:		Material no: 1.3343 or similar High-speed steel tools are typically used in applications with high cutting speeds. The high temperatures require particularly excellent tempering resistance and hot hardness. High-speed steel can be used at tool temperatures up to approx. 600°C.
		HSS = material code = "3"
	e.g.	Order no. = 220.3. ...
Carrier material	=	High-speed steel, nitrided (HST)
Characteristics:		Material no: 1.3343 or similar See HSS. The nitrogen nitrides diffused in during the nitriding treatment give the tool part even greater resistance to wear and the best possible protection against cold welding.
		HST = material code = "4"
	e.g.	Order no. = 223.4. ...
Carrier material	=	High-speed steel produced by powder metallurgy (ASP23/ASP2023)
Characteristics:		Material no: 1.3395 or similar High-speed steel produced by powder metallurgy. Greater toughness and resistance to wear than HSS due to excellent homogeneity of the material.
		ASP 23 ASP 2023 = material code = "6"
	e.g.	Order no. = 223.6. ...
Carrier material	=	Hot-work tool steel, nitrided (NWA)
Characteristics:		Material no: 1.2344 or similar Hot-work tool steels have particularly hot hardness, temper resistance, toughness and thermal shock resistance. Hot-work tool steels are used for temperatures above 200°C in continuous operation. The nitrogen nitrides diffused in during the nitriding treatment give the tool part even greater resistance to wear and the best possible protection against cold welding.
		NWA = material code number = "8"
	e.g.	Order no. = 237.8. ...
Carrier material	=	Carbide (HM)
Characteristics:		Powder metallurgically produced WC-based carbide. Carbide is characterised by high hardness and resistance to wear, resulting in excellent tool service life. Higher flexural strength and residual porosity through post-compaction in the HIP procedure.
		HM = material code = "9"
	e.g.	Order no. = 270.9. ...

GROUND PRECISION PARTS – MATERIALS AND COATINGS

Coating material

PVD titanium nitride TiN

Characteristics:

The titanium nitride coating TiN is a versatile "all-rounder" among coatings. Completely food safe, chemically resistant and biocompatible.

Surface hardness approx. 2300 HV 0,05

Layer thickness 2 - 4 µm

Friction value (dry steel) 0,4

Application temperature max. 600°C

Application area: Drawing, punching and forming tools for iron and steel plates.

TIN = material code letter "A" (carrier material HSS)

e.g. Order no. = 2209.A. ...

Coating material

PVD titanium carbonitride TiCN

Characteristics:

With the titanium carbonitride coating TiCN, the tool service life can usually be significantly increased again compared to TiN-coated tools due to a very good resistance to wear.

Surface hardness approx. 3000 HV 0,05

Layer thickness 2 - 4 µm

Friction value (dry steel) 0,4

Application temperature max. 400°C

Application area: Drawing, punching and forming tools for high-alloy and low-alloy sheet metal and stainless steel.

TICN = material code letter "B" (carrier material HSS)

e.g. Order no. = 2219.B. ...

Coating material

DLC (a-C:H)

Characteristics:

The "Diamond-like-carbon" layer DLC is particularly slippery, very hard and chemically resistant. Cold welds are avoided and tinsel formation is greatly reduced when cutting aluminium sheets.

Surface hardness up to 2300 HV 0,05

Layer thickness 1 - 3 µm

Friction value (dry steel) 0,1 - 0,2

Application temperature max. 300°C

Application area: Drawing, punching and forming tools, especially for aluminium processing

DLC = material code letter "C" (carrier material HSS)

e.g. Order no. = 2249.C. ...

All data are general reference values. No guarantee can be given for the geometry of the workpieces after coating. For special applications, please contact FIBRO.

SINTERED HARD METAL HIP-DENSIFIED

The HIP treatment (hot isostatic pressing) is a hot isostatic recompression of WC - Co - hard metals

With this procedure, which is widely used in hard metal technology, the material is recompressed under high pressure (1.2-3 kbar) after sintering in a high-temperature furnace below the sintering temperature.

This procedure reduces the residual porosity.

This reduction in porosity results in an improvement in the strength properties and, as a result, an increase in the service life of the tools used for press-working.

In addition to the compressive strength, the flexural strength in particular is increased, as can be seen from the diagrams and tables listed.

For sheet metal working, carbide grades of medium WC grain size, with 9-12 % Co content, are preferred for a wide range of applications.

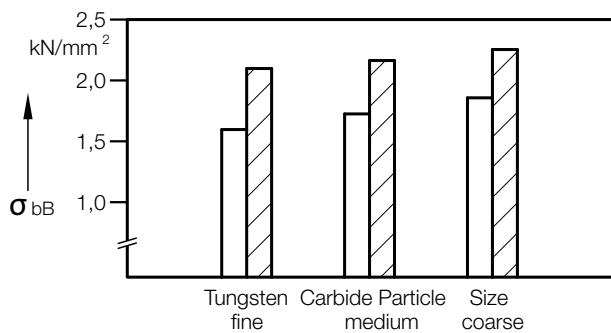

a) influence of crystallite size of hard metal phase
left: sintered only
right: sintered and HIP-treated).

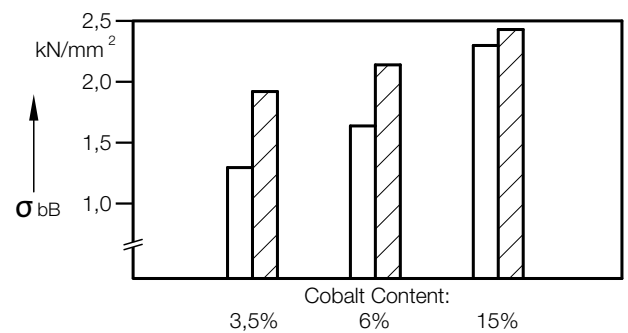

b) Influence of the cobalt content, sample condition as in figure a.
Flexural strength σ_{bB} of a WC-6Co alloy in the sintered and HIP-treated state as a function of various influencing variables.
Porosity in sintered condition: $\geq A1$
left, not shaded: Sintered condition
right, shaded: HIP-treated.

Change of Sintered Hard Metal by hot isostatic pressing

Tungsten carbide – particle size	Co %	Hardness HV ₃₀		Flexural Strength N/mm ²	
		before	after	before	after
feinfine	3	1800	no changes	1200	1700
	6	1650		1500	2300
	9	1400		2000	2600
medium	6	1600		2000	2600
	9	1450		2350	2700
	12	1300		2450	2900
coarse	15	1200		2700	2850
	6	1400		1900	2250
	8	1350		2300	2600
	10	1200		2650	2850

PUNCHES ~ DIN 9861

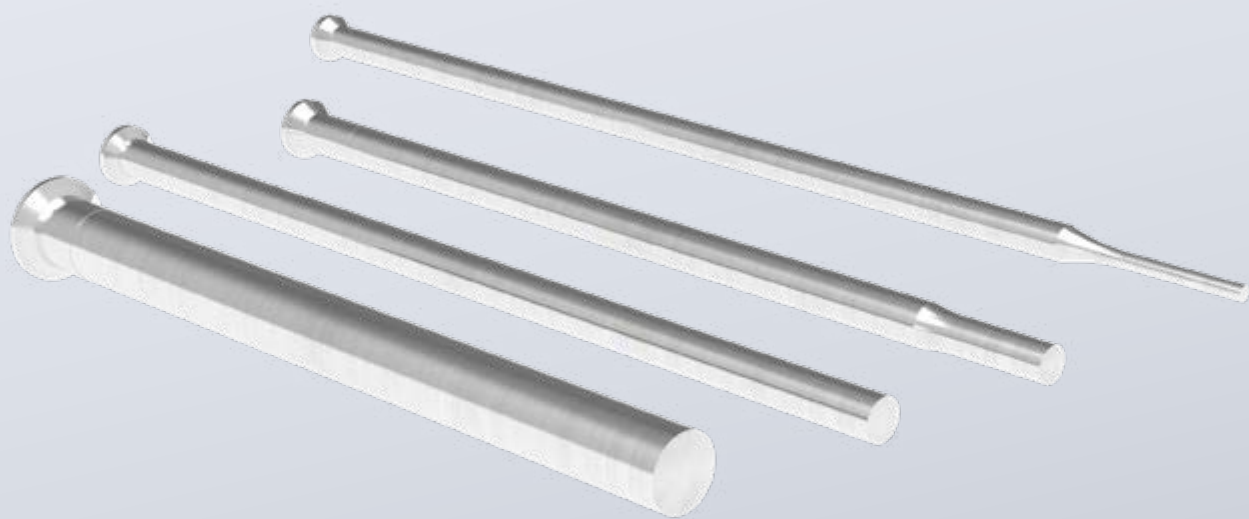

PUNCH DIN 9861 SHAPE DA



222.

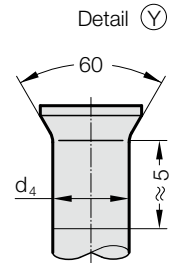
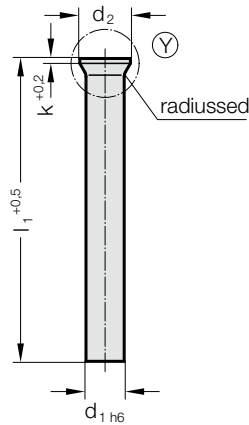

222. Punch DIN 9861 Shape DA

Gradation		d ₂	k	l ₁	71	80	100
d ₁	d ₁						
0,5	-	0,9	0,2		●	●	●
0,55	-	1	0,2		●	●	●
0,6	-	1,1	0,2		●	●	●
0,65	-	1,2	0,2		●	●	●
0,7	0,05	1,3	0,2		●	●	●
0,8	0,05	1,4	0,4		●	●	●
0,9	0,05	1,6	0,4		●	●	●
1	0,1	1,8	0,5		●	●	●
1,2	0,1	2	0,5		●	●	●
1,4	0,1	2,2	0,5		●	●	●
1,6	0,1	2,5	0,5		●	●	●
1,8	0,1	2,8	0,5		●	●	●
2	0,1	3	0,5		●	●	●
2,1	0,1	3,2	0,5		●	●	●
2,3	0,1	3,5	0,5		●	●	●
2,6	0,1	4	0,5		●	●	●
3	0,1	4,5	0,5		●	●	●
3,5	0,1	5	0,5		●	●	●
4	0,1	5,5	0,5		●	●	●
4,5	0,1	6	0,5		●	●	●
5	0,1	6,5	0,5		●	●	●
5,5	0,1	7	0,5		●	●	●
6	0,1	8	0,5		●	●	●
6,5	0,5	9	1		●	●	●
7,5	0,5	10	1		●	●	●
8,5	0,5	11	1		●	●	●
9,5	0,5	12	1		●	●	●
10,5	0,5	13	1		●	●	●
11,5	0,5	14	1		●	●	●
12,5	0,5	15	1		●	●	●
13,5	0,5	16	1,5		●	●	●
14,5	0,5	17	1,5		●	●	●
15,5	0,5	18	1,5		●	●	●

Material:

HSS
 Order No 222.3.
 Hardness:
 Shaft 64 ± 2 HRC
 Head 52 ± 3 HRC

HST
 Order No 222.4.
 Hardness:
 Surface ≥ 950 HV 0,3
 Head 52 ± 3 HRC

HZ - TIN (HSS)
 Order No 222.0.
 Hardness:
 Surface 2300 HV 0,05
 Head 52 ± 3 HRC

☞ Description of FIBRO materials for tool and die components see at the beginning of Chapter E.

Execution:

Shaft precision ground. Head hot upset-forged and tempered. Residual upset bulge below head normally much smaller than permissible acc. to DIN 9861.

d₄: For d₁ < 1 mm, d₄=d₁ + 0,02
 For d₁ ≥ 1 mm, d₄=d₁ + 0,03

Stock lengths: 71, 80, 100 mm.
 other lengths and diameters on request!

Note:

Punches are also available without head

Ordering Code (example):

Punch DIN 9861 Shape DA	=	222.
Material MAT	HSS	= 3.
Shaft diameter d ₁	3 mm	= 0300.
Length l ₁	71 mm	= 071
Order No	=	222.3.0300.071

PUNCH DIN 9861 SHAPE D / ISO 6752

223.

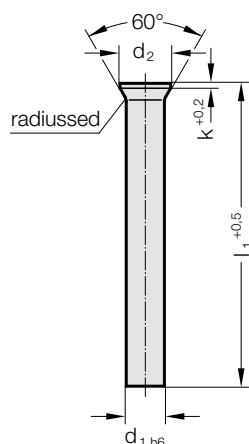

Material:

HSS
Order No 223.3.
Hardness:
Shaft 64 ± 2 HRC
Head 52 ± 3 HRC

HST
Order No 223.4.
Hardness:
Surface ≥ 950 HV 0,3
Head 52 ± 3 HRC

HZ - TIN (HSS)
Order No 223.0.
Hardness:
Surface 2300 HV 0,05
Head 52 ± 3 HRC

ASP 23 - ASP 2023
Order No 223.6.
Hardness:
Shaft 64 ± 2 HRC
Head 52 ± 3 HRC

Description of FIBRO materials for tool and die components see at the beginning of Chapter E.

Execution:

Head hot upset-forged and tempered. Shaft and head subsequently precision plunge-ground for perfect concentricity and full interchangeability with replacement punches.

Stock lengths: 71, 80, 100 mm.
other lengths and diameters on request!

223. Punch DIN 9861 Shape D / ISO 6752

d ₁	Gradation			71	80	100
	d ₁	d ₂	k			
0,5	-	0,9	0,2	●	●	●
0,55	-	1	0,2	●	●	●
0,6	-	1,1	0,2	●	●	●
0,65	-	1,2	0,2	●	●	●
0,7	0,05	1,3	0,2	●	●	●
0,8	0,05	1,4	0,4	●	●	●
0,9	0,05	1,6	0,4	●	●	●
1	0,1	1,8	0,5	●	●	●
1,2	0,1	2	0,5	●	●	●
1,4	0,1	2,2	0,5	●	●	●
1,6	0,1	2,5	0,5	●	●	●
1,8	0,1	2,8	0,5	●	●	●
2	0,1	3	0,5	●	●	●
2,1	0,1	3,2	0,5	●	●	●
2,3	0,1	3,5	0,5	●	●	●
2,6	0,1	4	0,5	●	●	●
3	0,1	4,5	0,5	●	●	●
3,5	0,1	5	0,5	●	●	●
4	0,1	5,5	0,5	●	●	●
4,5	0,1	6	0,5	●	●	●
5	0,1	6,5	0,5	●	●	●
5,5	0,1	7	0,5	●	●	●
6	0,1	8	0,5	●	●	●
6,5	0,5	9	1	●	●	●
7,5	0,5	10	1	●	●	●
8,5	0,5	11	1	●	●	●
9,5	0,5	12	1	●	●	●
10,5	0,5	13	1	●	●	●
11,5	0,5	14	1	●	●	●
12,5	0,5	15	1	●	●	●
13,5	0,5	16	1,5	●	●	●
14,5	0,5	17	1,5	●	●	●
15,5	0,5	18	1,5	●	●	●
16,5	0,5	19	1,5	●	●	●
17,5	0,5	20	1,5	●	●	●
18,5	0,5	21	1,5	●	●	●
19,5	0,5	22	1,5	●	●	●

Ordering Code (example):

Punch DIN 9861 Shape D / ISO 6752	=	223.
Material MAT	HSS	= 3.
Shaft diameter d ₁	4 mm	= 0400.
Length l ₁	71 mm	= 071
Order No		= 223.3.0400. 071

PUNCHES ~ DIN 9861 - ORDER SAMPLES

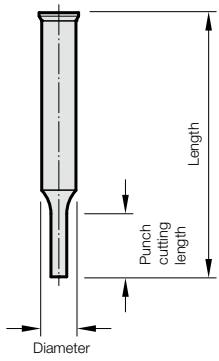

Punch:
22 without ejector pin

Note: See table for standard dimensions
Special dimensions to order

2 2 4 9 . 3 7 G 5 . 0 8 5 0 . 0 4 5 0 . A

Execution:	Order No
○ blank	= 0
⊙ round	= 1
□ square	= 2
▭ rectangular	= 3
⊖ slot	= 4
▭ rectangle with radiused corners	= 5
▽ Pilot pin with tapered tip	= 6
⤴ Pilot pin parabolic tip	= 7
special shapes	= 9

Type:	Order No
DIN 9861	= 9

Punch cutting length: l_1	Order No
8	= 1
10	= 2
13	= 3
19	= 4
25	= 5
30	= 6
special	= X

Length: l	Order Code character
71	= D
80	= E
100	= G
120	= J

Diameter: d_1	Order No
3	= 1
4	= 2
5	= 3
6	= 4
8	= 5
10	= 6
13	= 7
16	= 8
20	= 9

Shape: slot
Length P = 6,5 mm

Shape: slot
Width W = 4,5 mm

Angle:	Order Code character
0°	= A
90°	= B
180°	= C
270°	= D
special	= X

	without coating (Order No)	with coating (Order Code character)	TIN	TICN	DLC
Material:					
HSS	= 3		= A	= B	= C
ASP23	= 6		= D	= E	= F

📖 Description of FIBRO materials for tool and die components see at the beginning of Chapter E.

Ordering Code (example):

2 2 4 9 . 3 7 G 5 . 0 8 5 0 . 0 4 5 0 . A

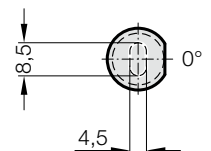
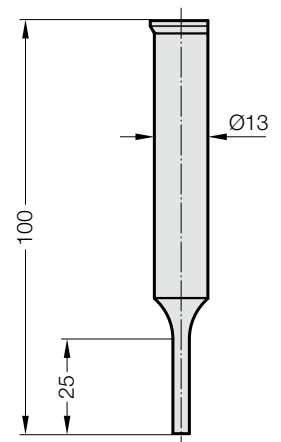
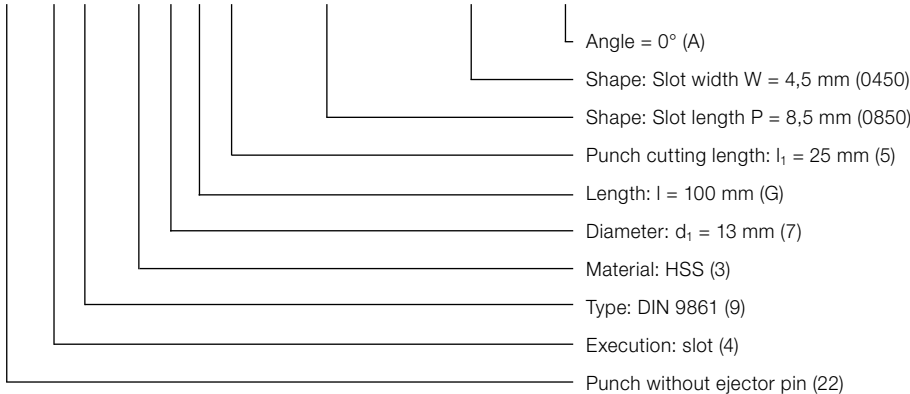

PUNCH, BLANK, DIN 9861, SHAPE D

2209.

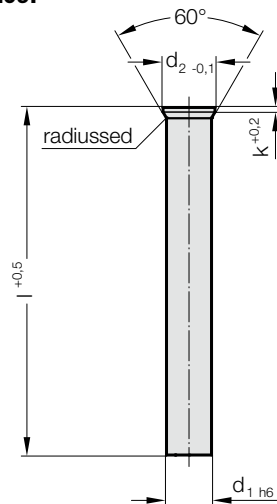

2209. Punch, blank, DIN 9861, Shape D

d ₁ / Order No	d ₂	k	l (Order Code character)	71 (D)	80 (E)	100 (G)	120 (J)
3/(1)	4.5	0.5		●	●	●	●
4/(2)	5.5	0.5		●	●	●	●
5/(3)	6.5	0.5		●	●	●	●
6/(4)	8	0.5		●	●	●	●
8/(5)	10	1		●	●	●	●
10/(6)	12	1		●	●	●	●
13/(7)	15	1		●	●	●	●
16/(8)	18	1.5		●	●	●	●
20/(9)	22	1.5		●	●	●	●

Ordering Code (example):

2209.37G

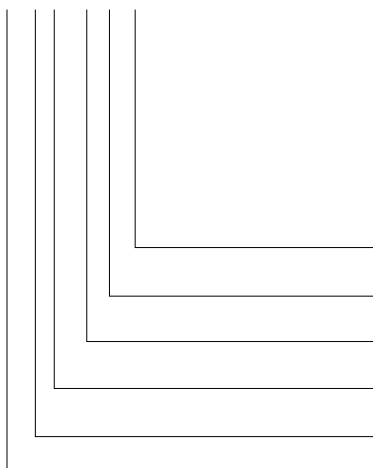

Length: l
100 mm
Diameter: d₁
13 mm
Material:
HSS
Type:
DIN 9861
Execution:
blank
Punch:
without ejector pin

Order Code character
= (G)
Order No
= (7)
Order No
= (3)
Order No
= (9)
Order No
= (0)
= 22

Material:

HSS
Order No 2209.3□□.
ASP 2023
Order No 2209.6□□.

Hardness:
Shaft 64 ± 2 HRC
Head 52 ± 5 HRC

Description of FIBRO materials for tool and die components see at the beginning of Chapter E.

Execution:

Stamp shank and punch head are precision ground after the heat compression and tempering of the punch head using the plunge process.

Other diameters and lengths upon request!

PUNCH, STEPPED, ROUND, ~DIN 9861

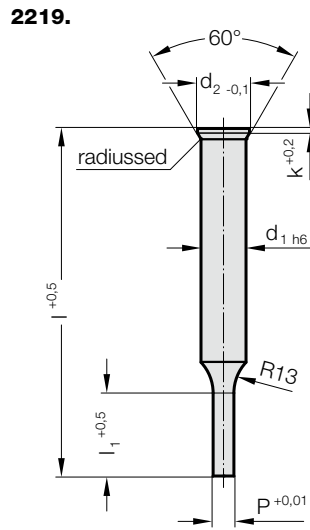

2219. Punch, stepped, round, ~DIN 9861

d ₁ / Order No	d ₂	P	I ₁ / Order No	k	I (Order Code character)	71 (D)	80 (E)	100 (G)	120 (J)
3 / (1)	4.5	0,8 - 2,9	8 (1) 10 (2)	0.5		●	●	●	●
4 / (2)	5.5	1 - 3,9	8 (1) 13 (3)	0.5		●	●	●	●
5 / (3)	6.5	1,5 - 4,9	13 (3) 19 (4)	0.5		●	●	●	●
6 / (4)	8	1,6 - 5,9	13 (3) 19 (4)	0.5		●	●	●	●
8 / (5)	10	2,5 - 7,9	19 (4) 25 (5)	1		●	●	●	●
10 / (6)	12	4 - 9,9	19 (4) 25 (5)	1		●	●	●	●
13 / (7)	15	5 - 12,9	19 (4) 25 (5)	1		●	●	●	●
16 / (8)	18	8 - 15,9	19 (4) 25 (5)	1.5		●	●	●	●
20 / (9)	22	12 - 19,9	19 (4) 25 (5)	1.5		●	●	●	●

Material:

HSS
 Order No 2219.3□□□.
 ASP 2023
 Order No 2219.6□□□.

Hardness:

Shaft 64 ± 2 HRC
 Head 52 ± 5 HRC

☞ Description of FIBRO materials for tool and die components see at the beginning of Chapter E.

Execution:

Stamp shank and punch head are precision ground after the heat compression and tempering of the punch head using the plunge process.

Ordering Code (example):

2219.37G4.0720

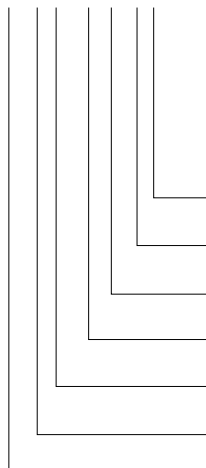

Shape: round
 P = ø 7,2 mm
Punch cutting length I₁
 19 mm
Length: I
 100 mm
Diameter: d₁
 13 mm
Material:
 HSS
Type:
 DIN 9861
Execution: Order No
 round
Punch:
 without ejector pin

Order No
 = 0720
Order No
 = (4)
Order Code character
 = (G)
Order No
 = (7)
Order No
 = (3)
Order No
 = (9)
 = (1)
 = 22

PUNCH, STEPPED, SQUARE, ~ DIN 9861

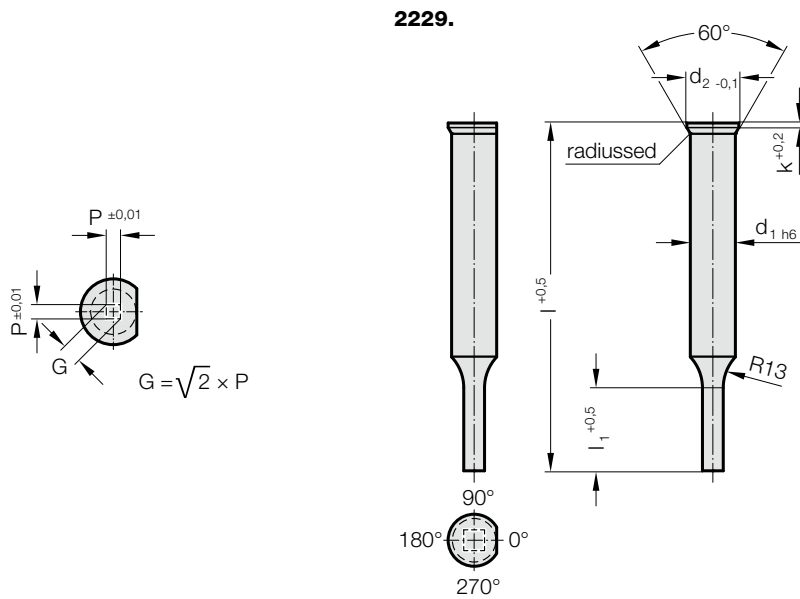

2229. Punch, stepped, square, ~ DIN 9861

d ₁ / Order No	d ₂	P _{min}	G _{max}	l ₁ / Order No	k	l (Order Code character)	71 (D)	80 (E)	100 (G)	120 (J)
3 / (1)	4.5	0.5	2.9	8 (1) 10 (2)	0.5		●	●	●	●
4 / (2)	5.5	0.8	3.9	8 (1) 13 (3)	0.5		●	●	●	●
5 / (3)	6.5	1	4.9	13 (3) 19 (4)	0.5		●	●	●	●
6 / (4)	8	1.6	5.9	13 (3) 19 (4)	0.5		●	●	●	●
8 / (5)	10	2	7.9	19 (4) 25 (5)	1		●	●	●	●
10 / (6)	12	3.5	9.9	19 (4) 25 (5)	1		●	●	●	●
13 / (7)	15	4.5	12.9	19 (4) 25 (5)	1		●	●	●	●
16 / (8)	18	6	15.9	19 (4) 25 (5)	1.5		●	●	●	●
20 / (9)	22	8	19.9	19 (4) 25 (5)	1.5		●	●	●	●

Ordering Code (example):

2229.39E5.1550.B

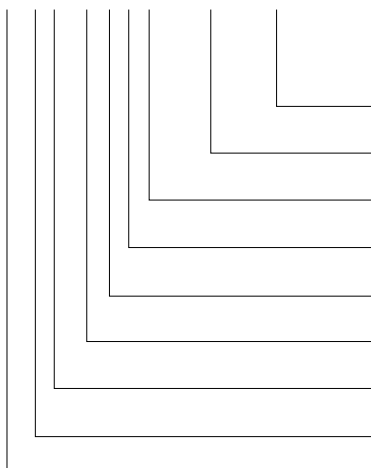

Angle:
90°

Shape: square, Length P
P = 15,5 mm

Punch cutting length: l₁
25 mm

Length: l
80 mm

Diameter: d₁
20 mm

Material:
HSS

Type:
DIN 9861

Execution: Order No
square

Punch:
without ejector pin

Order Code character
= (B)

= 1550

Order No
= (5)

Order Code character
= (E)

Order No
= (9)

Order No
= (3)

Order No
= (9)

= (2)

= 22

Material:

HSS
Order No 2229.3□□□.
ASP 2023
Order No 2229.6□□□.

Hardness:
Shaft 64 ± 2 HRC
Head 52 ± 5 HRC

Description of FIBRO materials for tool and die components see at the beginning of Chapter E.

Execution:

Punch head heat compressed. Contact area, shaft and cutting form precision ground. The locating flat is designed parallel with the dimension P = 0°.

Note:

With kerf ≤ 0.04 mm, FIBRO rounds off sharp edges, if the punch and bush are ordered together. This reduces the fitting time and the risk of an edge break during operation.

PUNCH, STEPPED, RECTANGULAR, ~DIN 9861



2239.

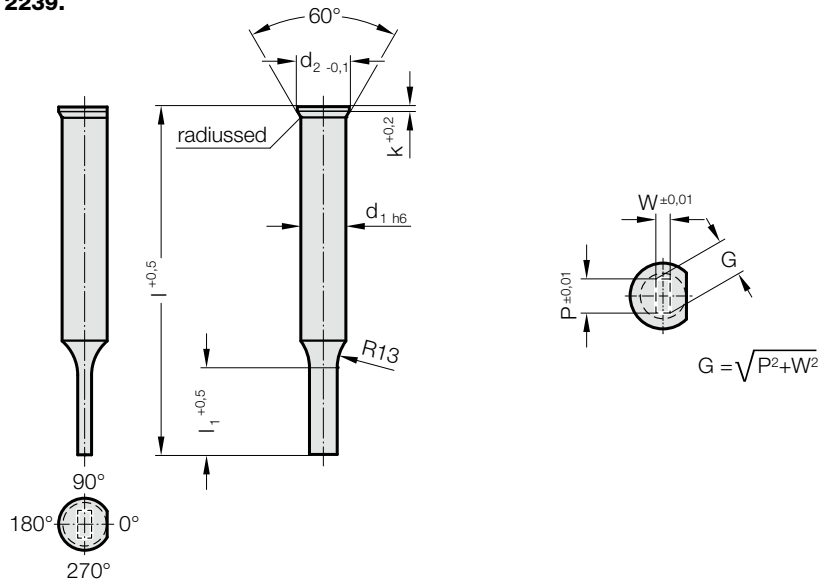

2239. Punch, stepped, rectangular, ~DIN 9861

d ₁ / Order No	d ₂	W _{min}	G _{max}	l ₁ / Order No	k	l (Order Code character)	71 (D)	80 (E)	100 (G)	120 (J)
3 / (1)	4.5	0.5	2.9	8 (1) 10 (2)	0.5		●	●	●	●
4 / (2)	5.5	0.8	3.9	8 (1) 13 (3)	0.5		●	●	●	●
5 / (3)	6.5	1	4.9	13 (3) 19 (4)	0.5		●	●	●	●
6 / (4)	8	1.6	5.9	13 (3) 19 (4)	0.5		●	●	●	●
8 / (5)	10	2	7.9	19 (4) 25 (5)	1		●	●	●	●
10 / (6)	12	3.5	9.9	19 (4) 25 (5)	1		●	●	●	●
13 / (7)	15	4.5	12.9	19 (4) 25 (5)	1		●	●	●	●
16 / (8)	18	6	15.9	19 (4) 25 (5)	1.5		●	●	●	●
20 / (9)	22	8	19.9	19 (4) 25 (5)	1.5		●	●	●	●

Material:

HSS

Order No 2239.3□□□.

ASP 2023

Order No 2239.6□□□.

Hardness:

Shaft 64 ± 2 HRC

Head 52 ± 5 HRC

Description of FIBRO materials for tool and die components see at the beginning of Chapter E.

Execution:

Punch head heat compressed. Contact area, shaft and cutting form precision ground. The locating flat is designed parallel with the dimension P = 0°.

Note:

With kerf ≤ 0.04 mm, FIBRO rounds off sharp edges, if the punch and bush are ordered together. This reduces the fitting time and the risk of an edge break during operation.

Ordering Code (example):

2239.39G4.1550.1150.B

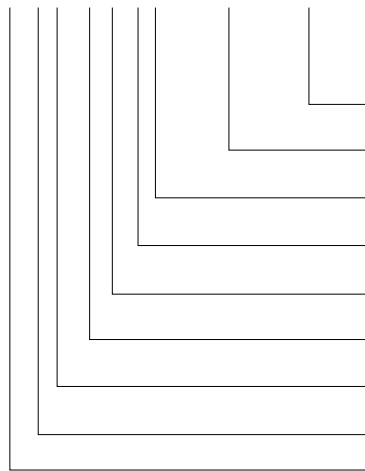

Angle:

90°

Shape: rectangular, Width W

W = 11,5 mm

Shape: rectangular, Length P

P = 15,5 mm

Punch cutting length l₁

19 mm

Length: l

100 mm

Diameter: d₁

20 mm

Material:

HSS

Type:

DIN 9861

Execution:

rectangular

Punch:

without ejector pin

Order Code character = (B)

= 1150

= 1550

Order No = (4)

= 1150

Order Code character = (G)

= 1550

Order No = (9)

= 1150

Order No = (3)

= 1550

Order No = (9)

= 1150

Order No = (3)

= 22

PUNCH, STEPPED, SLOT, ~ DIN 9861

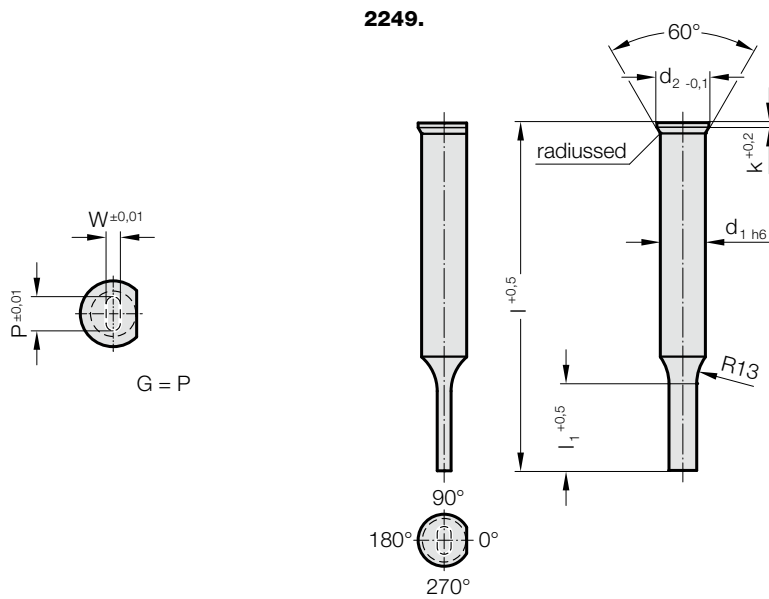

2249. Punch, stepped, slot, ~ DIN 9861

d ₁ / Order No	d ₂	W _{min}	G _{max}	l ₁ / Order No	k	l (Order Code character)	71 (D)	80 (E)	100 (G)	120 (J)
3 / (1)	4.5	0.5	2.9	8 (1) 10 (2)	0.5		●	●	●	●
4 / (2)	5.5	0.8	3.9	8 (1) 13 (3)	0.5		●	●	●	●
5 / (3)	6.5	1	4.9	13 (3) 19 (4)	0.5		●	●	●	●
6 / (4)	8	1.6	5.9	13 (3) 19 (4)	0.5		●	●	●	●
8 / (5)	10	2	7.9	19 (4) 25 (5)	1		●	●	●	●
10 / (6)	12	3.5	9.9	19 (4) 25 (5)	1		●	●	●	●
13 / (7)	15	4.5	12.9	19 (4) 25 (5)	1		●	●	●	●
16 / (8)	18	6	15.9	19 (4) 25 (5)	1.5		●	●	●	●
20 / (9)	22	8	19.9	19 (4) 25 (5)	1.5		●	●	●	●

Ordering Code (example):

2249.39G5.1650.1220.B

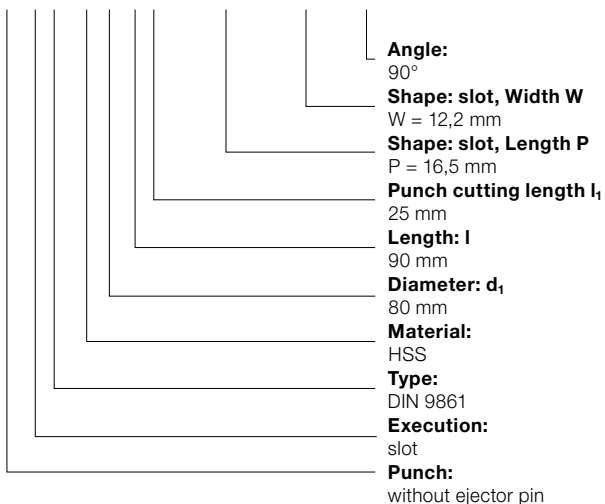

Order Code character
= (B)

= 1220

= 1650

Order No
= (5)

Order Code character
= (G)

Order No
= (9)

Order No
= (3)

Order No
= (9)

Order No
= (4)

= 22

Material:

HSS

Order No 2249.3□□□.

ASP 2023

Order No 2249.6□□□.

Hardness:

Shaft 64 ± 2 HRC

Head 52 ± 5 HRC

Description of FIBRO materials for tool and die components see at the beginning of Chapter E.

Execution:

Punch head heat compressed. Contact area, shaft and cutting form precision ground. The locating flat is designed parallel with the dimension P = 0°.

Note:

With kerf ≤ 0.04 mm, FIBRO rounds off sharp edges, if the punch and bush are ordered together. This reduces the fitting time and the risk of an edge break during operation.

PUNCH, STEPPED, RECTANGLE WITH RADIUSED CORNERS, ~DIN 9861



2259.

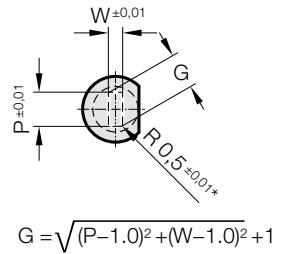
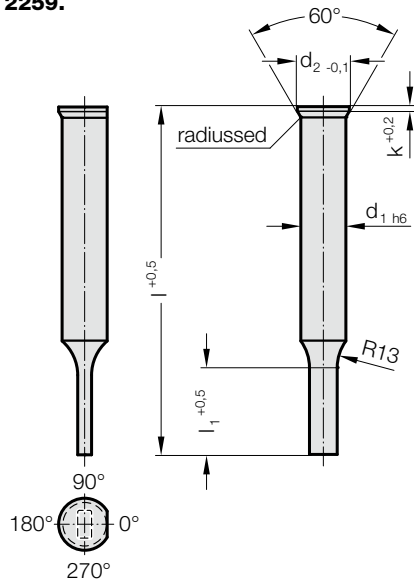

2259. Punch, stepped, rectangle with radiused corners, ~DIN 9861

d ₁ / Order No	d ₂	W _{min}	G _{max}	I ₁ / Order No	K	I (Order Code character)	71 (D)	80 (E)	100 (G)	120 (J)
3 / (1)	4.5	1.1	2.9	8 (1) 10 (2)	0.5		●	●	●	●
4 / (2)	5.5	1.1	3.9	8 (1) 13 (3)	0.5		●	●	●	●
5 / (3)	6.5	1.1	4.9	13 (3) 19 (4)	0.5		●	●	●	●
6 / (4)	8	1.6	5.9	13 (3) 19 (4)	0.5		●	●	●	●
8 / (5)	10	2	7.9	19 (4) 25 (5)	1		●	●	●	●
10 / (6)	12	3.5	9.9	19 (4) 25 (5)	1		●	●	●	●
13 / (7)	15	4.5	12.9	19 (4) 25 (5)	1		●	●	●	●
16 / (8)	18	6	15.9	19 (4) 25 (5)	1.5		●	●	●	●
20 / (9)	22	8	19.9	19 (4) 25 (5)	1.5		●	●	●	●

Material:

HSS

Order No 2259.3□□□.

ASP 2023

Order No 2259.6□□□.

Hardness:

Shaft 64 ± 2 HRC

Head 52 ± 5 HRC

Description of FIBRO materials for tool and die components see at the beginning of Chapter E.

Execution:

Punch head heat compressed. Contact area, shaft and cutting form precision ground. The locating flat is designed parallel with the dimension P = 0°.

Note:

With kerf ≤ 0.04 mm, FIBRO rounds off sharp edges, if the punch and bush are ordered together. This reduces the fitting time and the risk of an edge break during operation.

Ordering Code (example):

2259.39G4.1215.1150.B

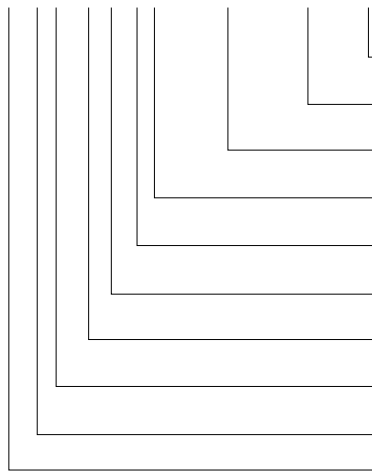

Angle: 90°	Order Code character = (B)
Shape: rectangle with radiused corners, Width W W = 11,5 mm	Order Code character = (1150)
Shape: rectangle with radiused corners, Length P P = 12,15 mm	Order Code character = (1215)
Punch cutting length I₁ 19 mm	Order No = (4)
Length: I 100 mm	Order Code character = (G)
Diameter: d₁ 20 mm	Order No = (9)
Material: HSS	Order No = (3)
Type: DIN 9861	Order No = (9)
Execution: rectangle with radiused corners	Order No = (5)
Punch: without ejector pin	Order No = 22

PUNCH DIN 9861 SHAPE CA



224.

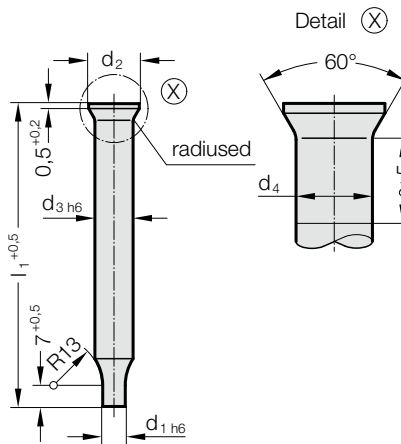

Material:

HSS

Order No 224.3.

Hardness:

Shaft 64 ± 2 HRC

Head 52 ± 3 HRC

HZ - TIN (HSS)

Order No 224.0.

Hardnes:

Surface 2300 HV 0,05

Head 52 ± 3 HRC

Description of FIBRO materials for tool and die components see at the beginning of Chapter E.

Execution:

Shaft precision ground. Head subsequently hot upset-forged and tempered; residual upset-buge below head normally much smaller than permissible acc. to DIN 9861.

Stock lengths: 71 mm.

Other lengths and diameters on request!

224. Punch DIN 9861 Shape CA

Gradation		d_1	d_2	d_3	d_4	l_1
d_1	d_1					
0,1 - 1,5	0.05	3	2	2.03	71	
1,55 - 2,95	0.05	4.5	3	3.03	71	

Ordering Code (example):

Punch DIN 9861 Shape CA	=	224.
Material MAT	HSS	= 3.
Cutting diameter d_1	1.55 mm	= 0155.
Length l_1	71 mm	= 071
Order No		= 224.3. 0155. 071

PUNCH DIN 9861 SHAPE C

225.

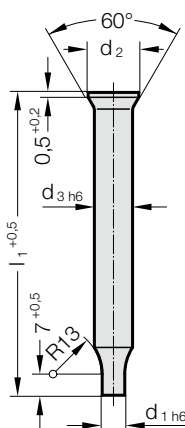

Material:

HSS
Order No 225.3.
Hardness:
Shaft 64 ± 2 HRC
Head 52 ± 3 HRC

HST
Order No 225.4.
Hardness:
Surface ≥ 950 HV 0,3
Head 52 ± 3 HRC

HZ - TIN (HSS)
Order No 225.0.
Hardness:
Surface 2300 HV 0,05
Head 52 ± 3 HRC

ASP 23 - ASP 2023
Order No 225.6.
Hardness:
Shaft 64 ± 2 HRC
Head 52 ± 3 HRC

Description of FIBRO materials for tool and die components see at the beginning of Chapter E.

Execution:

Head hot upset-forged and tempered. Shaft and head subsequently precision plunge-ground for perfect concentricity and full interchangeability with replacement punches.

Stock lengths: 71 mm.
Other lengths and diameters on request!

225. Punch DIN 9861 Shape C

d_1	Gradation		d_2	d_3	l_1
	d_1				
0,1 - 1,5	0,05		3	2	71
1,55 - 2,95	0,05		4,5	3	71

Ordering Code (example):

Punch DIN 9861 Shape C	=	225.
Material MAT	HSS	= 3.
Cutting diameter d_1	1.55 mm	= 0155.
Length l_1	71 mm	= 071
Order No		= 225. 3. 0155. 071

PUNCH SIMILAR TO DIN 9861 SHAPE CA



274.

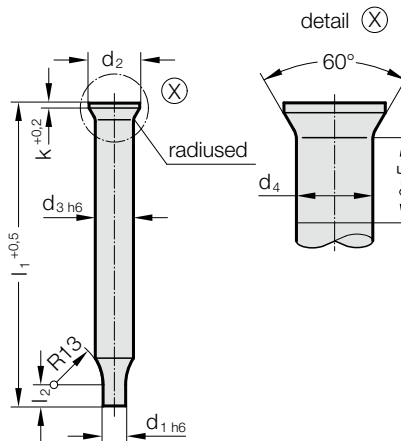

Description:

DIN 9861 restricts the range of stepped punches with conical head to shanks of 3 mm max. diameter and points of 2,95 mm max. diameter. Stepped punches of larger size are, however, quite popular owing to their rigidity and ability to sustain considerable stripping forces. In accommodation of this demand we supply larger sizes which are ground from stock sizes of the 222.-series.

Please select from those ranges and complete your order in accordance with the example on the right.

Material:

HSS

Order No 274.3.

Hardness:

Shaft 64 ± 2 HRC

Head 52 ± 3 HRC

HST

Order No 274.4.

Hardness:

Surface ≥ 950 HV 0,3

Head 52 ± 3 HRC

HZ - TIN (HSS)

Order No 274.0.

Hardness:

Surface 2300 HV 0,05

Head 52 ± 3 HRC

Description of FIBRO materials for tool and die components see at the beginning of Chapter E.

Execution:

Shaft precision ground. Head subsequently hot upset-forged and tempered; residual upset-buge below head normally much smaller than permissible acc. to DIN 9861.

Stock lengths: 71, 80, 100 mm.

other lengths and diameters on request!

274. Punch similar to DIN 9861 Shape CA

d ₁	Gradation			d ₄	l ₂	k	l ₁	71	80	100
	d ₁	d ₂	d ₃							
1 - 3,9	0.05	5.5	4	4.03	5 - 20	0.5		●	●	●
1,5 - 4,9	0.05	6.5	5	5.03	5 - 20	0.5		●	●	●
1,6 - 5,9	0.05	8	6	6.03	5 - 20	0.5		●	●	●
2,5 - 7,9	0.05	10	8	8.03	5 - 20	1		●	●	●
4 - 9,9	0.05	12	10	10.03	5 - 20	1		●	●	●
5 - 12,9	0.05	15	13	13.03	5 - 20	1		●	●	●
8 - 15,9	0.05	18	16	16.03	5 - 20	1.5		●	●	●

Ordering Code (example):

Punch similar to DIN 9861 Shape CA	= 274.
Material MAT	HSS = 3.
Shaft diameter d ₃	8 mm = 0800.
Length l ₁	71 mm = 071.
Cutting diameter d ₁	2.5 mm = 0250.
Cutting length l ₂	5 mm = 05
Order No	= 274.3. 0800.071.0250.05

PUNCH SIMILAR TO DIN 9861 SHAPE C

275.

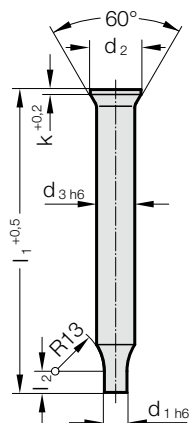

Description:

DIN 9861 restricts the range of stepped punches with conical head to shanks of 3 mm max. diameter and points of 2,95 mm max. diameter. Stepped punches of larger size are, however, quite popular owing to their rigidity and ability to sustain considerable stripping forces. In accommodation of this demand we supply larger sizes which are ground from stock sizes of the 223.-series

Please select from those ranges and complete your order in accordance with the example on the right.

Material:

HSS

Order No 275.3.

Hardness: Shaft 64 ± 2 HRC; Head 52 ± 3 HRC

HST

Order No 275.4.

Hardness: Surface ≥ 950 HV 0,3; Head 52 ± 3 HRC

HZ - TIN (HSS)

Order No 275.0.

Hardness: Surface 2300 HV 0,05; Head 52 ± 3 HRC

ASP 23 - ASP 2023

Order No 275.6.

Hardness: Shaft 64 ± 2 HRC; Head 52 ± 3 HRC

 Description of FIBRO materials for tool and die components see at the beginning of Chapter E.

Execution:

Head hot upset-forged and tempered. Shaft and head subsequently precision plunge-ground for perfect concentricity and full interchangeability with replacement punches.

Stock lengths: 71, 80, 100 mm.

other lengths and diameters on request!

275. Punch similar to DIN 9861 Shape C

Gradation									
d_1	d_1	d_2	d_3	l_2	k	l_1	71	80	100
1 - 3,9	0.05	5.5	4	5 - 20	0.5		●	●	●
1,5 - 4,9	0.05	6.5	5	5 - 20	0.5		●	●	●
1,6 - 5,9	0.05	8	6	5 - 20	0.5		●	●	●
2,5 - 7,9	0.05	10	8	5 - 20	1		●	●	●
4 - 9,9	0.05	12	10	5 - 20	1		●	●	●
5 - 12,9	0.05	15	13	5 - 20	1		●	●	●
8 - 15,9	0.05	18	16	5 - 20	1.5		●	●	●

Ordering Code (example):

Punch similar to DIN 9861 Shape C	= 275.
Material MAT	HSS = 3.
Shaft diameter d_3	8 mm = 0800.
Length l_1	71 mm = 071.
Cutting diameter d_1	2.5 mm = 0250.
Cutting length l_2	5 mm = 05
Order No	= 275.3. 0800.071.0250.05

PUNCH SIMILAR TO DIN 9861, SHAPE D



272.

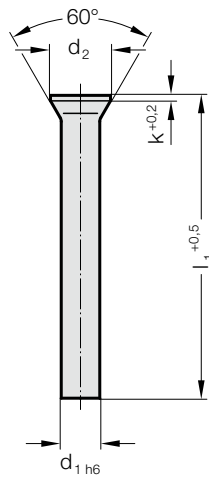

272. Punch similar to DIN 9861, Shape D

Gradation		d ₂	k	l ₁	71	80	100
d ₁	d ₁						
1.5	0.1	2.2	0.5		●	●	●
2	0.1	3	0.5		●	●	●
3 - 3.4	0.1	4.5	0.5		●	●	●
4 - 4.4	0.1	5.5	0.5		●	●	●
5 - 5.4	0.1	6.5	0.5		●	●	●
6 - 6.4	0.1	8	0.5		●	●	●
1.6 - 1.7	0.1	2.5	0.5		●	●	●
1.8 - 1.9	0.1	2.8	0.5		●	●	●
2.1 - 2.2	0.1	3.2	0.5		●	●	●
2.3 - 2.5	0.1	3.5	0.5		●	●	●
2.6 - 2.9	0.1	4	0.5		●	●	●
3.5 - 3.9	0.1	5	0.5		●	●	●
4.5 - 4.9	0.1	6	0.5		●	●	●
5.5 - 5.9	0.1	7	0.5		●	●	●
6.5 - 7	0.5	9	1		●	●	●
7.5 - 8	0.5	10	1		●	●	●
8.5 - 9	0.5	11	1		●	●	●
9.5 - 10	0.5	12	1		●	●	●
10.5 - 11	0.5	13	1		●	●	●
11.5 - 12	0.5	14	1		●	●	●
12.5 - 13	0.5	15	1		●	●	●
13.5 - 14	0.5	16	1.5		●	●	●
14.5 - 15	0.5	17	1.5		●	●	●
15.5 - 16	0.5	18	1.5		●	●	●

Material:

Tungsten-Cobalt-Carbide
Order No 272.9.

Execution:

Shaft precision ground.
Head: Steel, brazed to shaft or Tungsten-Cobalt Carbide.

Other diameters and lengths on request.

Ordering Code (example):

Punch similar to DIN 9861, Shape D	= 272.9.
Shaft diameter d ₁	5 mm = 0500.
Length l ₁	71 mm = 071
Order No	= 272.9. 0500.071

PUNCH SIMILAR TO DIN 9861, SHAPE C

273.

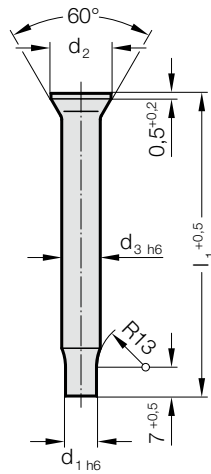

Material:

Tungsten-Cobalt-Carbide
Order No 273.9.

Execution:

Shaft precision ground.
Head: Steel, brazed to shaft or Tungsten-Cobalt Carbide.

Other diameters and lengths on request.

273. Punch similar to DIN 9861, Shape C

		Gradation			
d_1	d_1	d_2	d_3	l_1	
0.5 - 1.5	0.05	3	2	71	
1.55 - 2.95	0.05	4.5	3	71	

Ordering Code (example):

Punch similar to DIN 9861, Shape C	= 273.9.
Cutting diameter d_1	1.75 mm = 0175.
Length l_1	71 mm = 071
Order No	= 273.9. 0175. 071

PUNCHES WITH TAPERED HEAD 30°

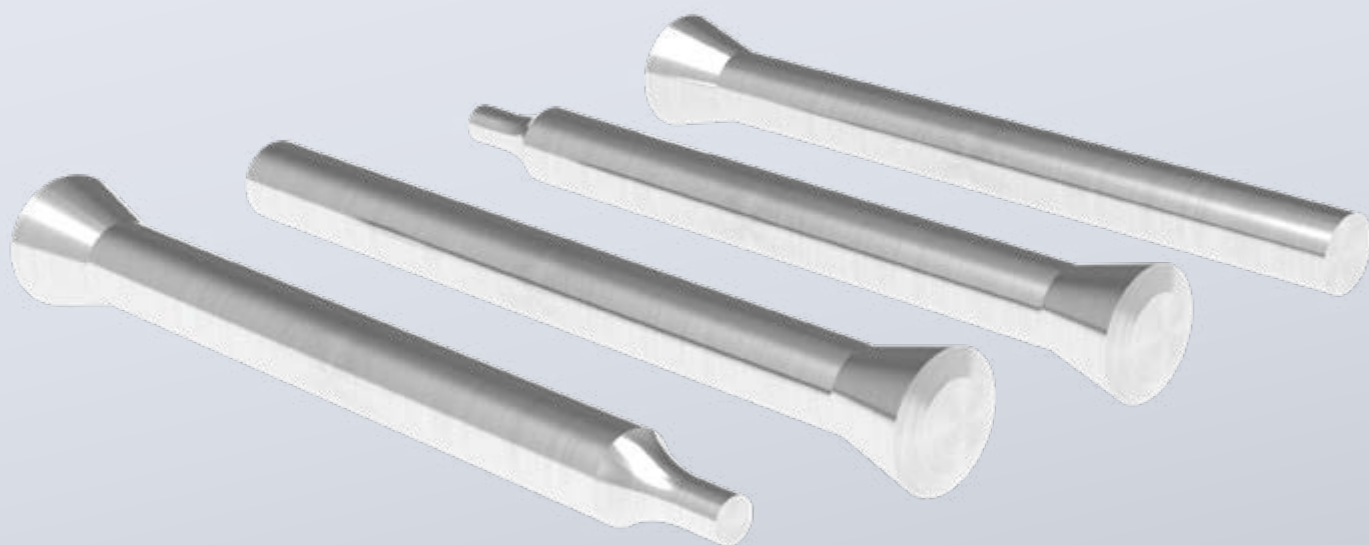

PUNCH WITH TAPERED HEAD 30°, SHAPE D



2281.

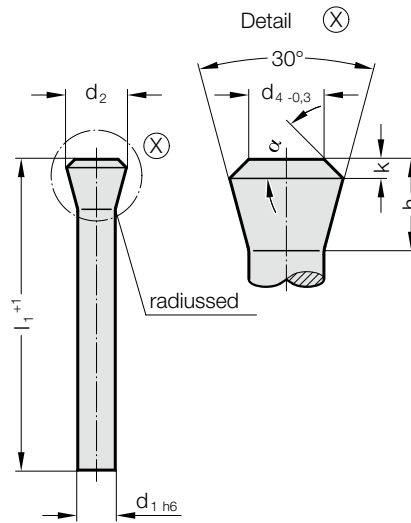

2281. Punch with tapered head 30°, Shape D

d ₁	d ₂	d ₄	h	k	α ± 1°	l ₁	100	120
5.5	8.98	5.5	7.5	1	30		●	●
6	9.75	6	8	1	28		●	●
8	12.8	8	10	1	22.5		●	●
9	14.4	9	11	1	20		●	●
10	15.9	10	12	1	19		●	●
12	18.7	12	14	1.5	24			●
14	21.8	14	16	1.5	21			●
16	24.6	16	18	2	25			●

Material:

HSS

Order No 2281.3.

Hardness:

Shaft 58 + 2 HRC

Head ≤ 50 HRC

Description of FIBRO materials for tool and die components see at the beginning of Chapter E.

Execution:

Head hot upset-forged and tempered. Shaft and head subsequently precision plunge-ground for perfect concentricity and full interchangeability with replacement punches.

Ordering Code (example):

Punch with tapered head 30°, Shape D = 2281.

Material MAT HSS = 3.

Shaft diameter d₁ 10 mm = 1000.

Length l₁ 100 mm = 100

Order No = 2281.3.1000.100

PUNCH WITH TAPERED HEAD 30°, SHAPE C

2291.

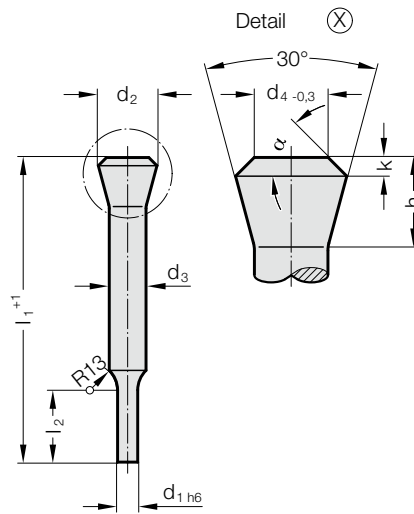

Material:

HSS

Order No 2291.3.

Hardness:

Shaft 58 + 2 HRC

Head ≤ 50 HRC

 Description of FIBRO materials for tool and die components see at the beginning of Chapter E.

Execution:

Head hot upset-forged and tempered. Shaft and head subsequently precision plunge-ground for perfect concentricity and full interchangeability with replacement punches.

d₁ and l₂ to customer's specifications!

2291. Punch with tapered head 30°, Shape C

d ₃	d ₂	d ₄	h	k	α ± 1°	l ₁	100	120
5.5	8.98	5.5	7.5	1	30		●	●
6	9.75	6	8	1	28		●	●
8	12.8	8	10	1	22.5		●	●
9	14.4	9	11	1	20		●	●
10	15.9	10	12	1	19		●	●
12	18.7	12	14	1.5	24			●
14	21.8	14	16	1.5	21			●
16	24.6	16	18	2	25			●

Ordering Code (example):

Punch with tapered head 30°, Shape C	=	2291.
Material MAT	HSS	= 3.
Shaft diameter d ₃	10 mm	= 1000.
Length l ₁	100 mm	= 100.
Cutting diameter d ₁	5 mm	= 0500.
Cutting length l ₂	5 mm	= 005
Order No	=	2291. 3.1000. 100.0500. 005

PUNCHES WITH TAPERED HEAD

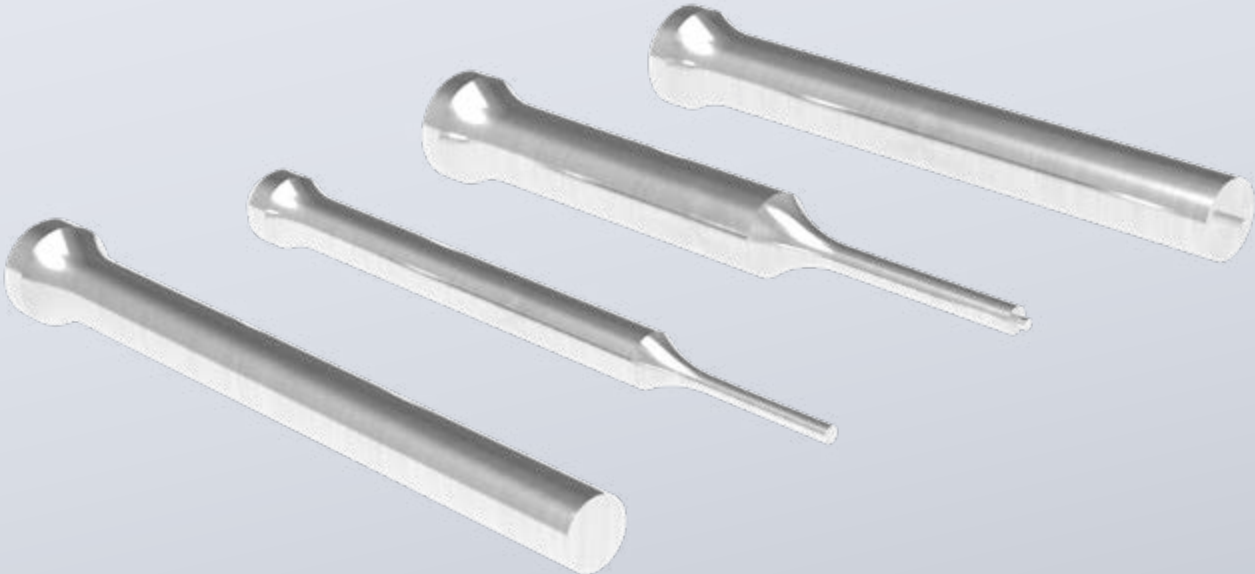

PUNCH WITH TAPERED HEAD, DIN 5118 SHAPE A



2284.3. Punch with tapered head, DIN 5118 Shape A

d ₁	d ₂	a	k	r	l	71	80	100	110
2	3	1	3	3.5		●	●	●	
2.1	3.2	1	3	5		●	●	●	
2.2	3.2	1	3	5		●	●	●	
2.3	3.5	1	3	5		●	●	●	
2.4	3.5	1	3	5		●	●	●	
2.5	3.5	1	3	5		●	●	●	
2.6	4	1	3	6.5		●	●	●	
2.7	4	1	3	6.5		●	●	●	
2.8	4	1	3	6.5		●	●	●	
2.9	4	1	3	6.5		●	●	●	
3.1	4.5	1	3	6.5		●	●	●	
3.2	4.5	1	3	6.5		●	●	●	
3.3	4.5	1	3	6.5		●	●	●	
3.4	4.5	1	3	6.5		●	●	●	
3.5	5	1	3	8		●	●	●	
3.6	5	1	3	8		●	●	●	
3.7	5	1	3	8		●	●	●	
3.8	5	1	3	8		●	●	●	
4.1	5.5	1.5	4	8		●	●	●	
4.2	5.5	1.5	4	8		●	●	●	
4.3	5.5	1.5	4	8		●	●	●	
4.4	5.5	1.5	4	8		●	●	●	
4.5	6	1.5	4	8		●	●	●	
4.6	6	1.5	4	8		●	●	●	
4.7	6	1.5	4	8		●	●	●	
4.8	6	1.5	4	8		●	●	●	
4.9	6	1.5	4	8		●	●	●	
5.1	7	1.5	4	10		●	●	●	
5.2	7	1.5	4	10		●	●	●	
5.5	8	1.5	4	10		●	●	●	
5.6	8	1.5	4	10		●	●	●	
6.1	9	1.5	4	10		●	●	●	
6.2	9	1.5	4	10		●	●	●	
6.3	9	1.5	4	10		●	●	●	
6.4	9	1.5	4	10		●	●	●	
6.5	10	1.5	4	12		●	●	●	●
7	10	1.5	4	12		●	●	●	●
7.5	11	1.5	4	12		●	●	●	●
7.7	11	1.5	4	12		●	●	●	●
8.1	11	1.5	4	12		●	●	●	●
8.5	13	1.5	4	15		●	●	●	●
9	13	1.5	4	15		●	●	●	●
9.5	14	1.5	4	15		●	●	●	●
10.5	15	1.5	4	15		●	●	●	●
11	15	1.5	4	15		●	●	●	●
11.5	16	1.5	4	15		●	●	●	●
12	16	1.5	4	15		●	●	●	●
12.5	17	1.5	4	15		●	●	●	●
13.5	18	1.5	4	15		●	●	●	●
14	18	1.5	4	15		●	●	●	●
14.5	19	1.5	4	15		●	●	●	●
15	19	1.5	4	15		●	●	●	●
15.5	20	1.5	4	15		●	●	●	●
17	21	1.5	4	15		●	●	●	●
18	22	1.5	4	15		●	●	●	●
19	23	1.5	4	15		●	●	●	●
19.5	25	1.5	4	15		●	●	●	●

2284.3.

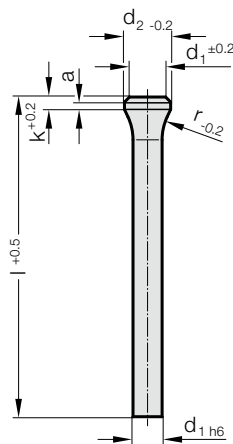

Material:

HSS
 Order No 2284.3.
 Hardness:
 Shaft 62-66 HRC
 Head 45-55 HRC

☞ Description of FIBRO materials for tool and die components see at the beginning of Chapter E.

Execution:

Shaft precision ground. Head subsequently hot upset-forged and tempered.

Note:

Matching piloted counterbore 2284.00.

Ordering Code (example):

Punch with tapered head,			
DIN 5118 Shape A		= 2284.3.	
Shaft diameter d ₁	5.2 mm	=	0520.
Length l	80 mm	=	080
Order No		= 2284.3. 0520. 080	

PUNCH WITH TAPERED HEAD, BLANK, DIN 5118 SHAPE A

2206.

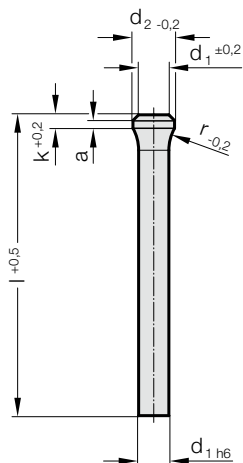

2206. Punch with tapered head, blank, DIN 5118 Shape A

d ₁ / Order No	d ₂	a	k	r	l (Order Code character)	71 (D)	80 (E)	90 (F)	100 (G)	120 (J)	150 (M)	200 (N)
3/(1)	4.5	1	3	6.5		●	●	●	●	●		
4/(2)	5.5	1.5	4	8		●	●	●	●	●		
5/(3)	7	1.5	4	10		●	●	●	●	●		
6/(4)	9	1.5	4	10		●	●	●	●	●		
8/(5)	11	1.5	4	12		●	●	●	●	●		
10/(6)	14	1.5	4	15		●	●	●	●	●	●	
13/(7)	17	1.5	4	15		●	●	●	●	●	●	●
16/(8)	20	1.5	4	15		●	●	●	●	●	●	●
20/(9)	25	1.5	4	15		●	●	●	●	●	●	●

Ordering Code (example):

2206.7G

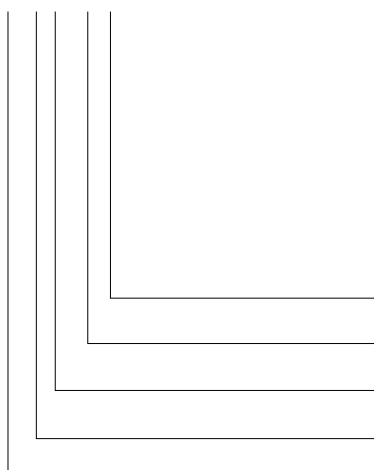

Length: l
100 mm
Diameter: d₁
13 mm
Type:
with tapered head
Execution:
blank
Punch:
without ejector pin

Order Code character
= (G)
Order No
= (7)
Order No
= (6)
Order No
= (0)
= 22

Material:

HSS
Hardness:
Shaft 62-66 HRC
Head 45-55 HRC

 Description of FIBRO materials for tool and die components see at the beginning of Chapter E.

Execution:

Shaft precision ground. Head subsequently hot upset-forged and tempered.

Note:

Matching piloted counterbore 2284.00.
Matching retainer ring 2284.00.01.

PUNCH WITH TAPERED HEAD, STEPPED, ROUND, ~DIN 5118 SHAPE B



2216.

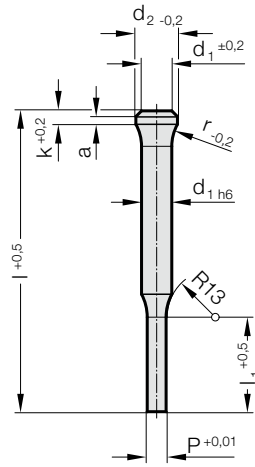

2216. Punch with tapered head, stepped, round, ~DIN 5118 Shape B

d ₁ / Order No	d ₂	P	l ₁ / Order No	a	k	r	l (Order Code character)	71 (D)	80 (E)	90 (F)	100 (G)	120 (J)	150 (M)	200 (N)
3 / (1)	4.5	0.8-2.9	8(1) 10(2)	1	3	6.5		●	●	●	●	●		
4 / (2)	5.5	1.0-3.9	8(1) 13(3)	1.5	4	8		●	●	●	●	●		
5 / (3)	7	1.5-4.9	13(3) 19(4)	1.5	4	10		●	●	●	●	●		
6 / (4)	9	1.6-5.9	13(3) 19(4)	1.5	4	10		●	●	●	●	●		
8 / (5)	11	2.5-7.9	19(4) 25(5)	1.5	4	12		●	●	●	●	●		
10 / (6)	14	4.0-9.9	19(4) 25(5)	1.5	4	15		●	●	●	●	●	●	
13 / (7)	17	5.0-12.9	19(4) 25(5)	1.5	4	15		●	●	●	●	●	●	●
16 / (8)	20	8.0-15.9	19(4) 25(5)	1.5	4	15		●	●	●	●	●	●	●
20 / (9)	25	12.0-19.9	19(4) 25(5)	1.5	4	15		●	●	●	●	●	●	●

Material:

HSS

Hardness:

Shaft 62-66 HRC

Head 45-55 HRC

☞ Description of FIBRO materials for tool and die components see at the beginning of Chapter E.

Execution:

Shaft precision ground. Head subsequently hot upset-forged and tempered.

Note:

Matching piloted counterbore 2284.00.

Matching retainer ring 2284.00.01.

Ordering Code (example):

2216.7G4.0720

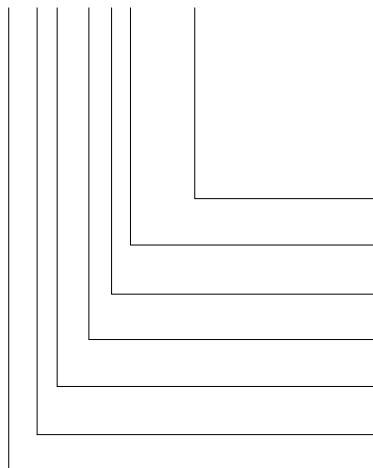

Shape: round

P = ø7,2 mm

Punch cutting length: l₁
19 mm

Length: l
100 mm

Diameter: d₁
13 mm

Type:
with tapered head

Execution:
round

Punch:
without ejector pin

= 0720

Order No
= (4)

Order Code character
= (G)

Order No
= (7)

Order No
= (6)

Order No
= (1)

= 22

PUNCH WITH TAPERED HEAD, BLANK, WITH EJECTOR PIN, DIN 5118 SHAPE E

2706.

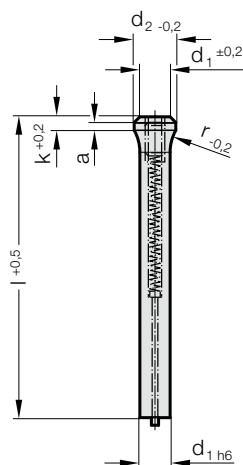

2706. Punch with tapered head, blank, with ejector pin, DIN 5118 Shape E

d ₁ / Order No	d ₂	a	k	r	l (Order Code character)	71 (D)	80 (E)	90 (F)	100 (G)	120 (J)
5 / (3)	7	1.5	4	10		●	●	●	●	●
6 / (4)	9	1.5	4	10		●	●	●	●	●
8 / (5)	11	1.5	4	12		●	●	●	●	●
10 / (6)	14	1.5	4	15		●	●	●	●	●
13 / (7)	17	1.5	4	15		●	●	●	●	●
16 / (8)	20	1.5	4	15		●	●	●	●	●
20 / (9)	25	1.5	4	15		●	●	●	●	●

Ordering Code (example):

2706.7G

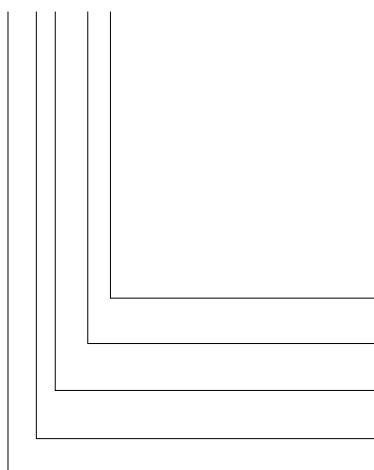

Length: l
100 mm

Diameter: d₁
13 mm

Type:
with tapered head

Execution:
blank

Punch:
with ejector pin

Order Code character
= (G)

Order No
= (7)

Order No
= (6)

Order No
= (0)

= 27

Material:

HSS

Hardness:

Shaft 62-66 HRC

Head 45-55 HRC

 Description of FIBRO materials for tool and die components see at the beginning of Chapter E.

Execution:

Shaft precision ground. Head subsequently hot upset-forged and tempered.

Note:

Matching piloted counterbore 2284.00.

Matching retainer ring 2284.00.01.

PUNCH WITH TAPERED HEAD, STEPPED, ROUND, WITH EJECTOR PIN, ~DIN 5118 SHAPE F



2716.

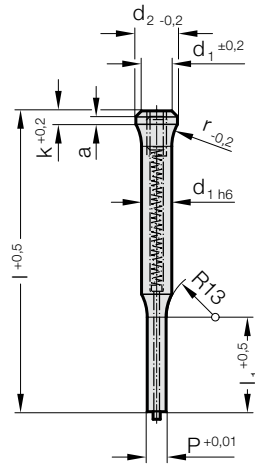

2716. Punch with tapered head, stepped, round, with ejector pin, ~DIN 5118 Shape F

d ₁ / Order No	d ₂	P	l ₁ / Order No	a	k	r	l (Order Code character)	71 (D)	80 (E)	90 (F)	100 (G)	120 (J)
5 / (3)	7	2 - 4.9	13 (3) 19 (4)	1.5	4	10		●	●	●	●	●
6 / (4)	9	2.5 - 5.9	13 (3) 19 (4)	1.5	4	10		●	●	●	●	●
8 / (5)	11	4 - 7.9	19 (4) 25 (5)	1.5	4	12		●	●	●	●	●
10 / (6)	14	5 - 9.9	19 (4) 25 (5)	1.5	4	15		●	●	●	●	●
13 / (7)	17	6 - 12.9	19 (4) 25 (5)	1.5	4	15		●	●	●	●	●
16 / (8)	20	8 - 15.9	19 (4) 25 (5)	1.5	4	15		●	●	●	●	●
20 / (9)	25	10 - 19.9	19 (4) 25 (5)	1.5	4	15		●	●	●	●	●

Material:

HSS

Hardness:

Shaft 62-66 HRC

Head 45-55 HRC

☞ Description of FIBRO materials for tool and die components see at the beginning of Chapter E.

Execution:

Shaft precision ground. Head subsequently hot upset-forged and tempered.

Note:

Matching piloted counterbore 2284.00.

Matching retainer ring 2284.00.01.

Ordering Code (example):

2716.7G4.0720

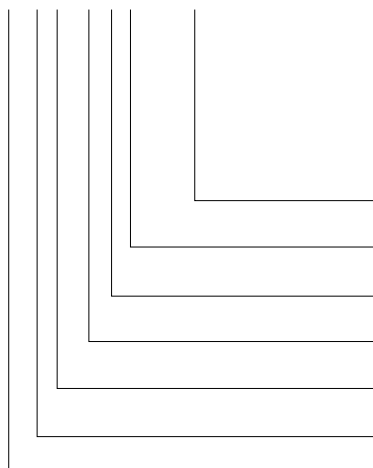

Shape: round

P = ø7,2 mm

Punch cutting length: l₁
19 mm

Length: l
100 mm

Diameter: d₁
13 mm

Type:
with tapered head

Execution:
round

Punch:
with ejector pin

= 0720

Order No
= (4)

Order Code character
= (G)

Order No
= (7)

Order No
= (6)

Order No
= (1)

= 27

PILOTED COUNTERBORE FOR TAPERED-HEAD PUNCH

2284.00. Piloted counterbore for tapered-head punch

d ₁	d _s	d ₃	r ₁	l ₁
2	3.3	3.3	3.5	5
2.1	3.5	3.5	5	5
2.2	3.5	3.5	5	5
2.3	3.8	3.8	5	5
2.4	3.8	3.8	5	5
2.5	3.8	3.8	5	5
2.6	4.3	4.3	6.5	7
2.7	4.3	4.3	6.5	7
2.8	4.3	4.3	6.5	7
2.9	4.3	4.3	6.5	7
3	4.9	4.9	6.5	7
3.1	4.9	4.9	6.5	7
3.2	4.9	4.9	6.5	7
3.3	4.9	4.9	6.5	7
3.4	4.9	4.9	6.5	7
3.5	5.4	5.4	8	8
3.6	5.4	5.4	8	8
3.7	5.4	5.4	8	8
3.8	5.4	5.4	8	8
4	5.9	5.9	8	8
4.1	5.9	5.9	8	8
4.2	5.9	5.9	8	8
4.3	5.9	5.9	8	8
4.4	5.9	5.9	8	8
4.5	6.4	6.4	8	8
4.6	6.4	6.4	8	8
4.7	6.4	6.4	8	8
4.8	6.4	6.4	8	8
4.9	6.4	6.4	8	8
5	7.4	7.4	10	10
5.1	7.4	7.4	10	10
5.2	7.4	7.4	10	10
5.5	8.5	8.5	10	10
5.6	8.5	8.5	10	10
6	9.5	9.5	10	10
6.1	9.5	9.5	10	10
6.2	9.5	9.5	10	10
6.3	9.5	9.5	10	10
6.4	9.5	9.5	10	10
6.5	10.5	10.5	12	12
7	10.5	10.5	12	12
7.5	11.5	11.5	12	12
7.7	11.5	11.5	12	12
8	11.5	11.5	12	12
8.1	11.5	11.5	12	12
8.5	13.5	13	15	12
9	13.5	13	15	12
9.5	14.5	13	15	12
10	14.5	13	15	12
10.5	15.5	13	15	15
11	15.5	13	15	15
11.5	16.5	13	15	15
12	16.5	13	15	15
12.5	17.5	13	15	15
13	17.5	13	15	15
13.5	18.5	13	15	15
14	18.5	13	15	15
14.5	19.5	13	15	15
15	19.5	13	15	15
15.5	20.5	13	15	15
16	20.5	13	15	15
17	21.5	16	15	15
18	22.5	16	15	15
19	23.5	16	15	15
19.5	25.5	16	15	15
20	25.5	16	15	15



2284.00.

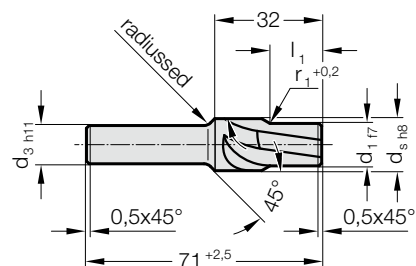

Material:

HSS, hardened 62-66 HRC

Execution:

Tempered and ground.

Ordering Code (example):

Piloted counterbore for tapered-head punch = 2284.00.
Punch shaft diameter d₁ 5.6 mm = 0560
Order No = 2284.00. 0560

MOUNTING RING FOR PUNCH WITH TAPERED HEAD



2284.00.01.

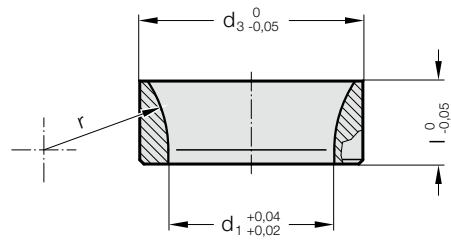

Mounting example

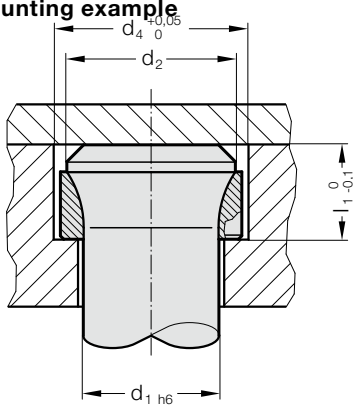

2284.00.01. Mounting ring for punch with tapered head

Order No	d ₁	d ₂	d ₃	d ₄	l	l ₁	r
2284.00.01.0300	3	4.5	5.9	6	4	7	6.5
2284.00.01.0400	4	5.5	6.9	7	4	8	8
2284.00.01.0500	5	7	8.9	9	7	11	10
2284.00.01.0600	6	9	10.9	11	7	11	10
2284.00.01.0800	8	11	12.9	13	8	12	12
2284.00.01.1000	10	14	15.9	16	9	13	15
2284.00.01.1300	13	17	18.9	19	9	13	15
2284.00.01.1600	16	20	21.9	22	9	13	15
2284.00.01.2000	20	25	26.9	27	10	14	15

Material:

Tool steel, heat-treated

Note:

Used for punch with tapered neck

PUNCHES DIN 9844

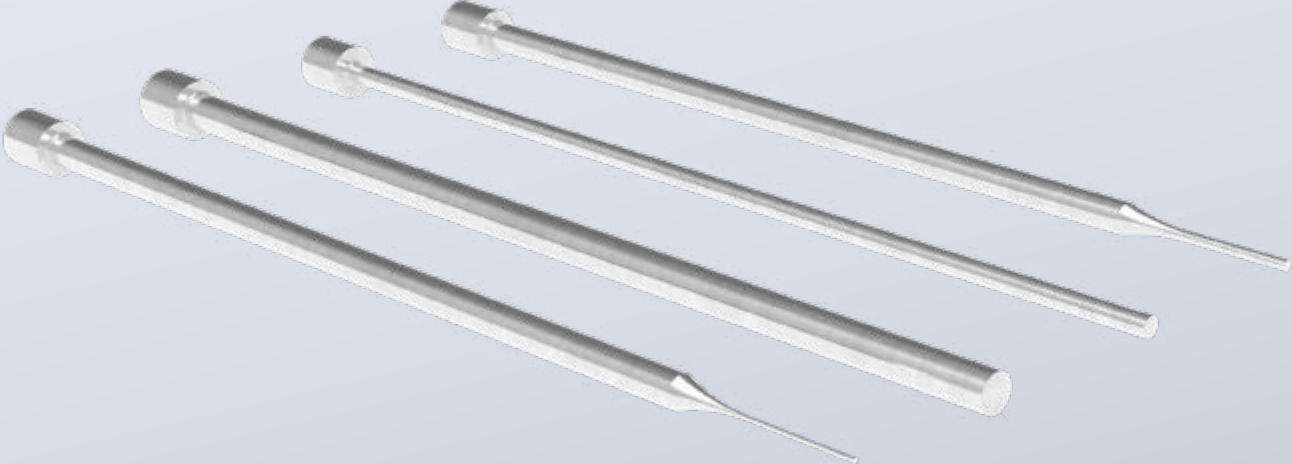

PUNCHES DIN 9844 - INSTALLATION GUIDELINES

Description:

Head type punches with round point (DIN 9844) are intended for floating assembly in the punch retainer. If there is sufficient clearance between the cutting punch, punch mounting plate and pressure plate, bending stresses can be avoided that can be caused by misalignments.

a) for rigid installation

b) with forced centring by the countersunk head

With punches held in this manner, a clear separation between transmission of perforation force and guiding is achieved.

In order to facilitate assembly of punches of different diameters, the height of the heads is standardized to $4^{+0.2}$ mm (DIN 9844).

Guide Lines:

excerpts from DIN 9844, page 5

d_1 max. = stock thickness

Stripping force:

for d_1 from 1 to 5 mm = 20% of the cutting force

for d_1 from 5.1 to 16 mm = 10% of the cutting force

Cutting material: max. $\sigma_{\text{B}} = 400 \text{ N/mm}^2$

Punch retainer plate made from St 50-2 with $\sigma_{\text{D perm.}} = 300 \text{ N/mm}^2$

Locating hole in the punch retainer plate: $1.05 \times d_1$ or d_2

Clearance punch head/percussion plate = 0.02 mm.

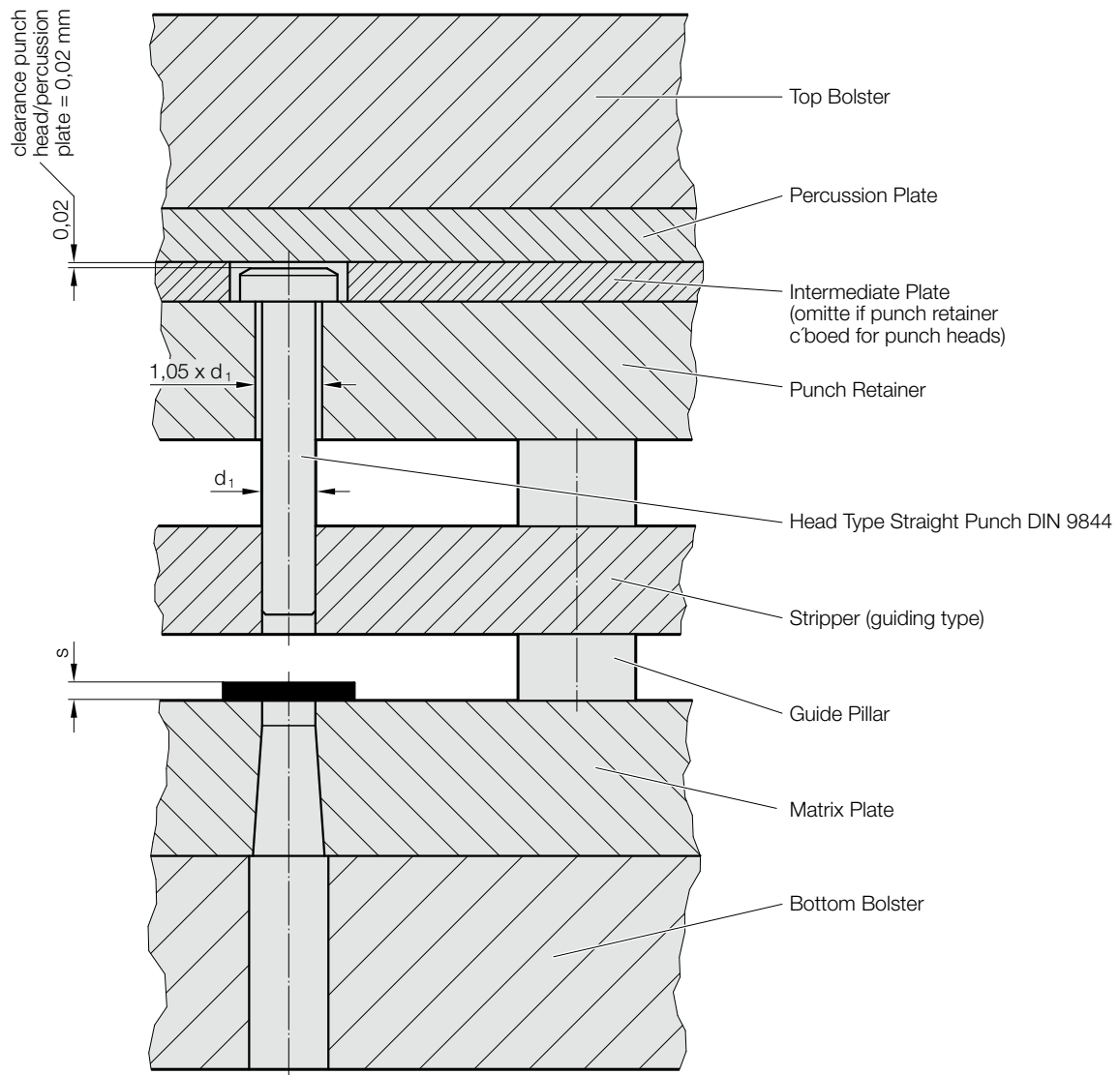

PUNCH DIN 9844, SHAPE A

220.

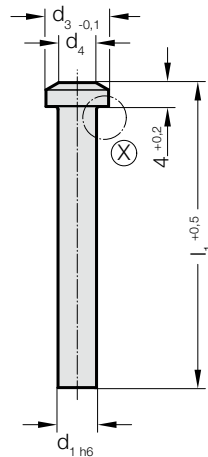
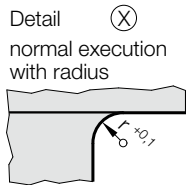

$$d_4 = d_1^{+0,5}$$



Material:

HSS
Order No 220.3.
Hardness:
Shaft 64 ± 2 HRC
Head 52 ± 3 HRC

HST
Order No 220.4.
Hardness:
Surface ≥ 950 HV 0,3
Head 52 ± 3 HRC

Description of FIBRO materials for tool and die components see at the beginning of Chapter E.

Execution:

Punch head hot upset-forged. Shaft and shoulder precision plunge-ground.

Stock lengths: 71, 90, 112 mm.
other lengths and diameters on request!

220. Punch DIN 9844, Shape A

d ₁	Gradation			l ₁	71	90	112
	d ₁	d ₃	r				
2	0.1	3.6	0.2		●	●	●
2.3	0.1	4	0.2		●	●	●
2.6	0.1	4.5	0.3		●	●	●
2.9	0.1	5	0.3		●	●	●
3.3	0.1	6	0.3		●	●	●
3.6	0.1	7	0.3		●	●	●
4.1	0.1	8	0.5		●	●	●
4.6	0.1	8.5	0.5		●	●	●
5.1	0.1	9	0.5		●	●	●
5.5	0.1	9.5	0.5		●	●	●
6	0.1	10	0.5		●	●	●
6.5	0.5	10.8	0.7		●	●	●
7.5	0.5	12	0.7		●	●	●
8.5	0.5	13	0.7		●	●	●
9.5	0.5	14.5	0.7		●	●	●
10.5	0.5	16	1		●	●	●
11.5	0.5	18	1		●	●	●
13	0.5	20	1		●	●	●
15	0.5	22	1		●	●	●

Ordering Code (example):

Punch DIN 9844, Shape A	=	220.
Material MAT	HSS	= 3.
Cutting diameter d ₁	5.5 mm	= 0550.
Length l ₁	71 mm	= 071
Order No	=	220. 3.0550. 071

PUNCH DIN 9844, SHAPE B



221.

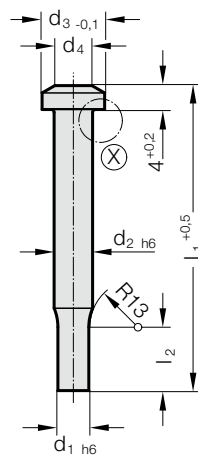

$$d_4 = d_1^{+0,5}$$

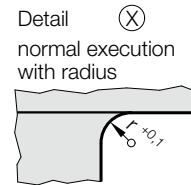

221. Punch DIN 9844, Shape B

Gradation										
d ₁	d ₁	d ₂	d ₃	l ₂	r	l ₁	71	90	112	
0.1	0.05	2	3.6	7	0.2		●	●	●	
1.95	0.05	2.5	4	7	0.2		●	●	●	
2.5	0.1	3.2	5	7	0.3		●	●	●	
3.2	0.1	4	7	7	0.3		●	●	●	
4	0.1	5	8.5	7	0.5		●	●	●	
5	0.1	6.3	10	7	0.5		●	●	●	
6.3	0.1	8	12	16	0.7		●	●	●	
8	0.1	10	14.5	16	0.7		●	●	●	
10	0.1	12.5	18	16	1		●	●	●	
12.5	0.1	16	22	16	1		●	●	●	

Material:

HSS

Order No 221.3.

Hardness:

Shaft 64 ± 2 HRC

Head 52 ± 3 HRC

HST

Order No 221.4.

Hardness:

Surface ≥ 950 HV 0,3

Head 52 ± 3 HRC

📖 Description of FIBRO materials for tool and die components see at the beginning of Chapter E.

Execution:

Punch head hot upset-forged. Shaft and shoulder precision plunge-ground.

Stock lengths: 71, 90, 112 mm.

other lengths and diameters on request!

Ordering Code (example):

Punch DIN 9844, Shape B	=	221.
Material MAT	HSS	= 3.
Cutting diameter d ₁	5 mm	= 0500.
Length l ₁	71 mm	= 071
Order No	=	221.3.0500. 071

PUNCH SIMILAR TO DIN 9844, SHAPE A

270.

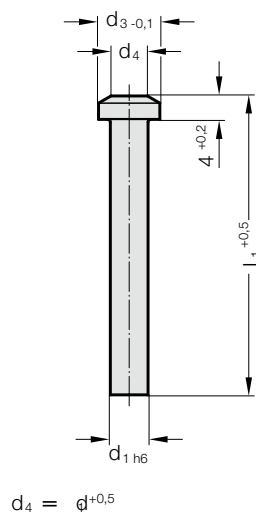

Material:

Tungsten-Cobalt-Carbide
Order No 270.9.

Execution:

Shaft precision ground.
Head: Steel, brazed to shaft or Tungsten-Cobalt Carbide.

Other diameters and lengths on request.

270. Punch similar to DIN 9844, Shape A

Gradation					71	90	112
d_1	d_1	d_3	r	l_1			
1	0.1	3,6	0.2		●	●	●
2.3	0.1	4	0.2		●	●	●
2.6	0.1	4.5	0.3		●	●	●
2.9	0.1	5	0.3		●	●	●
3.3	0.1	6	0.3		●	●	●
3.6	0.1	7	0.3		●	●	●
4.1	0.1	8	0.5		●	●	●
4.6	0.1	8.5	0.5		●	●	●
5.1	0.1	9	0.5		●	●	●
5.5	0.1	9.5	0.5		●	●	●
6	0.1	10	0.5		●	●	●
6.5	0.5	10.8	0.7		●	●	●
7.5	0.5	12	0.7		●	●	●
8.5	0.5	13	0.7		●	●	●
9.5	0.5	14.5	0.7		●	●	●
10.5	0.5	16	1		●	●	●
11.5	0.5	18	1		●	●	●
13	0.5	20	1		●	●	●
15	0.5	22	1		●	●	●

Ordering Code (example):

Punch similar to DIN 9844, Shape A	=	270.9.
Shaft diameter d_1	4.7 mm =	0470.
Length l_1	71 mm =	071
Order No	=	270.9. 0470. 071

PUNCH SIMILAR TO DIN 9844, SHAPE B



271.

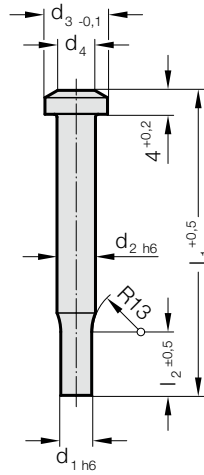

$$d_4 = d_1^{+0,5}$$

271. Punch similar to DIN 9844, Shape B

Gradation										
d ₁	d ₁	d ₂	d ₃	l ₂	r	l ₁	71	90	112	
0.5	0.05	2	3.6	7	0.2		●	●	●	
1.95	0.05	2.5	4	7	0.2		●	●	●	
2.5	0.1	3.2	5	7	0.3		●	●	●	
3.2	0.1	4	7	7	0.3		●	●	●	
4	0.1	5	8.5	7	0.5		●	●	●	
5	0.1	6.3	10	7	0.5		●	●	●	
6.3	0.1	8	12	16	0.7		●	●	●	
8	0.1	10	14.5	16	0.7		●	●	●	
10	0.1	12.5	18	16	1		●	●	●	
12.5	0.1	16	22	16	1		●	●	●	

Material:

Tungsten-Cobalt-Carbide
Order No 271.9.

Execution:

Shaft precision ground.
Head: Steel, brazed to shaft or Tungsten-Cobalt Carbide.

Other diameters and lengths on request.

Ordering Code (example):

Punch similar to DIN 9844, Shape B	=	271.9.
Cutting diameter d ₁	7.3 mm =	0730.
Length l ₁	71 mm =	071
Order No	=	271.9. 0730. 071

PUNCHES WITH CYLINDRICAL HEAD

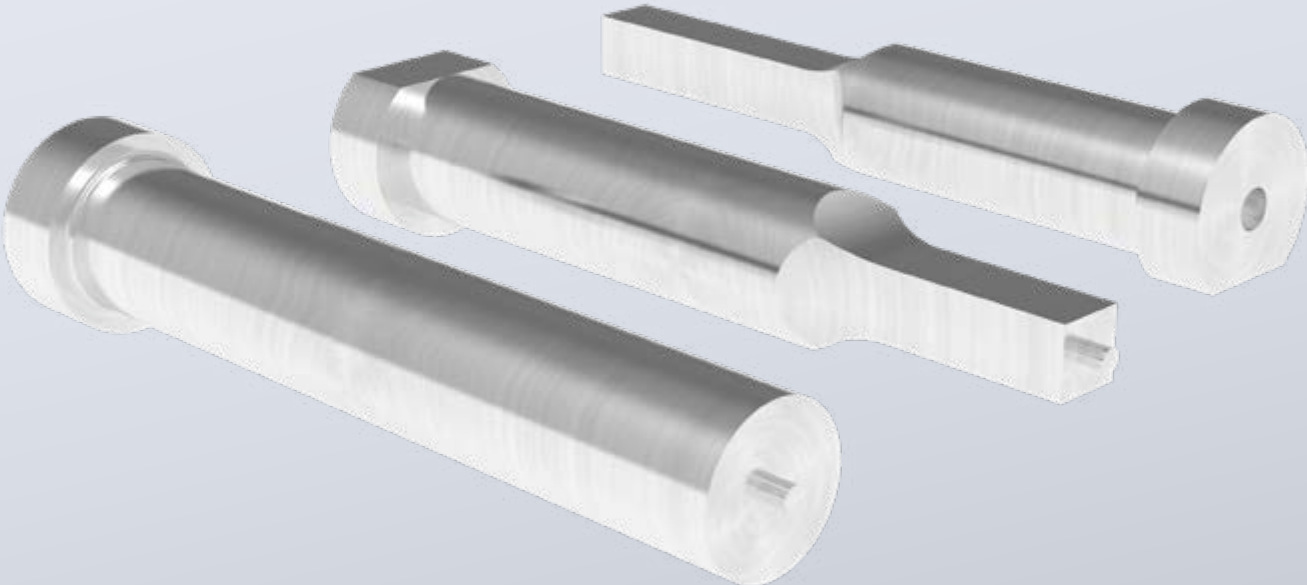

PUNCH WITH EJECTOR PIN



267.

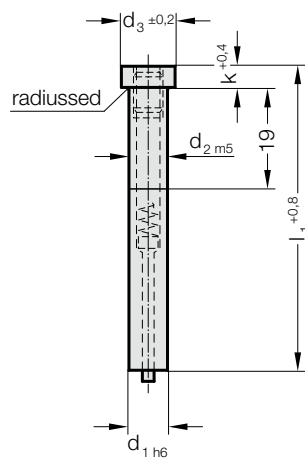

267. Punch with ejector pin

$d_{1\ h6}$	d_3	k	l_1	60	71	80	90	100
5	8	5		●	●	●	●	●
6	9	5		●	●	●	●	●
8	11	5		●	●	●	●	●
10	13	5		●	●	●	●	●
13	16	5		●	●	●	●	●
16	19	6.4		●	●	●	●	●
20	23	6.4		●	●	●	●	●
25	28	6.4		●	●	●	●	●

Material:

HSS

Order No 267.3.

Hardness:

Shaft 64 ± 2 HRC

Head 52 ± 5 HRC

Description of FIBRO materials for tool and die components see at the beginning of Chapter E.

Execution:

Punch head hot upset-forged. Shaft and shoulder precision plunge-ground.

Ordering Code (example):

Punch with ejector pin	=	267.
Material MAT	HSS	= 3.
Shaft diameter d_1	13 mm	= 1300.
Length l_1	60 mm	= 060
Order No	=	267. 3.1300.060

PUNCH WITH EJECTOR PIN, STEPPED, SHORT POINT

268.

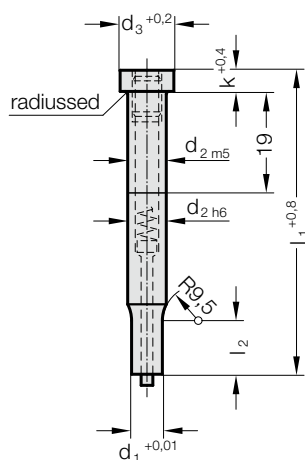
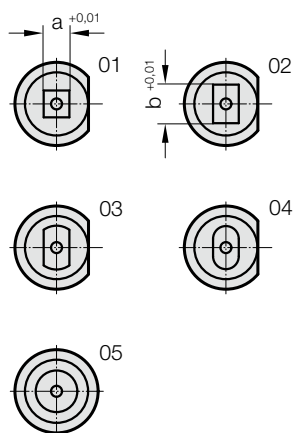

Material:

HSS
Order No 268.3.
Hardness:
Shaft 64 ± 2 HRC
Head 52 ± 5 HRC

Description of FIBRO materials for tool and die components see at the beginning of Chapter E.

Execution:

Punch head hot upset-forged. Shaft and shoulder precision plunge-ground.

Key flats parallel with longest size of shape, unless otherwise specified.

Note:

With kerf ≤ 0.04 mm, FIBRO rounds off sharp edges for shape 01 and shape 02 if the punch and piercing die bushing are ordered together. This reduces the fitting time and the risk of an edge break during operation.

268. Punch with ejector pin, stepped, short point

d_1	d_2	d_3	k	l_2	a_{min}	l_1	60	71	80	90	100
1.6 - 4.9	5	8	5	7	1.6		●	●	●	●	●
2.3 - 5.9	6	9	5	7	2.3		●	●	●	●	●
3.2 - 7.9	8	11	5	13	3.2		●	●	●	●	●
4.8 - 9.9	10	13	5	13	4.8		●	●	●	●	●
4.8 - 12.9	13	16	5	13	4.8		●	●	●	●	●
5.5 - 15.9	16	19	6.4	13	5.5		●	●	●	●	●
5.5 - 19.9	20	23	6.4	13	5.5		●	●	●	●	●
6.5 - 24.9	25	28	6.4	13	6.5		●	●	●	●	●

Ordering Code (example):

Punch with ejector pin, stepped, short point	=	268.3.
Shaft diameter d_2	13 mm =	1300.
Length l_1	60 mm =	060.
Cutting form FORM	square =	01.
Cutting form width a	4.8 mm =	0480.
Cutting form length b	4.8 mm =	0480
Order No	=	268.3. 1300.060. 01.0480. 0480

PUNCH WITH EJECTOR PIN, STEPPED, LONG POINT



269.

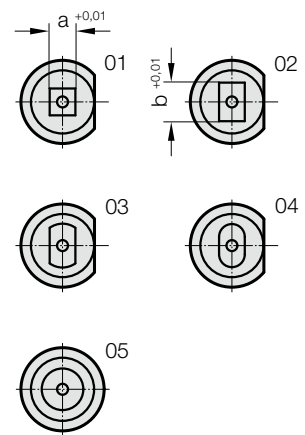
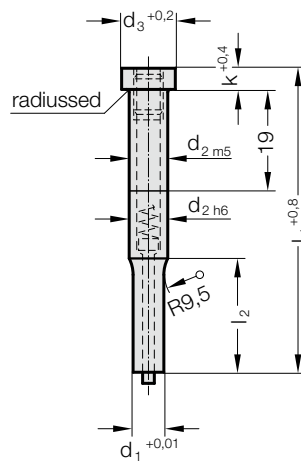

269. Punch with ejector pin, stepped, long point

d ₁	d ₂	d ₃	k	l ₂	a _{min}	l ₁	60	71	80	90	100
2,3 - 5,9	6	9	5	17,5	2,3		●	●	●	●	●
3,2 - 7,9	8	11	5	25	3,2		●	●	●	●	●
4,8 - 9,9	10	13	5	28	4,8		●	●	●	●	●
4,8 - 12,9	13	16	5	28	4,8		●	●	●	●	●
5,5 - 15,9	16	19	6,4	28	5,5		●	●	●	●	●
5,5 - 19,9	20	23	6,4	28	5,5		●	●	●	●	●
6,5 - 24,9	25	28	6,4	28	6,5		●	●	●	●	●

Material:

HSS
 Order No 269.3.
 Hardness:
 Shaft 64 ± 2 HRC
 Head 52 ± 5 HRC

☞ Description of FIBRO materials for tool and die components see at the beginning of Chapter E.

Execution:

Punch head hot upset-forged. Shaft and shoulder precision plunge-ground.

Key flats parallel with longest size of shape, unless otherwise specified.

Note:

With kerf ≤ 0.04 mm, FIBRO rounds off sharp edges for shape 01 and shape 02 if the punch and piercing die bushing are ordered together. This reduces the fitting time and the risk of an edge break during operation.

Ordering Code (example):

Punch with ejector pin, stepped, long point	=	269.3.
Shaft diameter d ₂	13 mm =	1300.
Length l ₁	60 mm =	060.
Cutting form FORM	square =	01.
Cutting form width a	4.8 mm =	0480.
Cutting form length b	4.8 mm =	0480
Order No	=	269.3. 1300. 060. 01.0480. 0480

PUNCHES SQUARE/RECTANGULAR

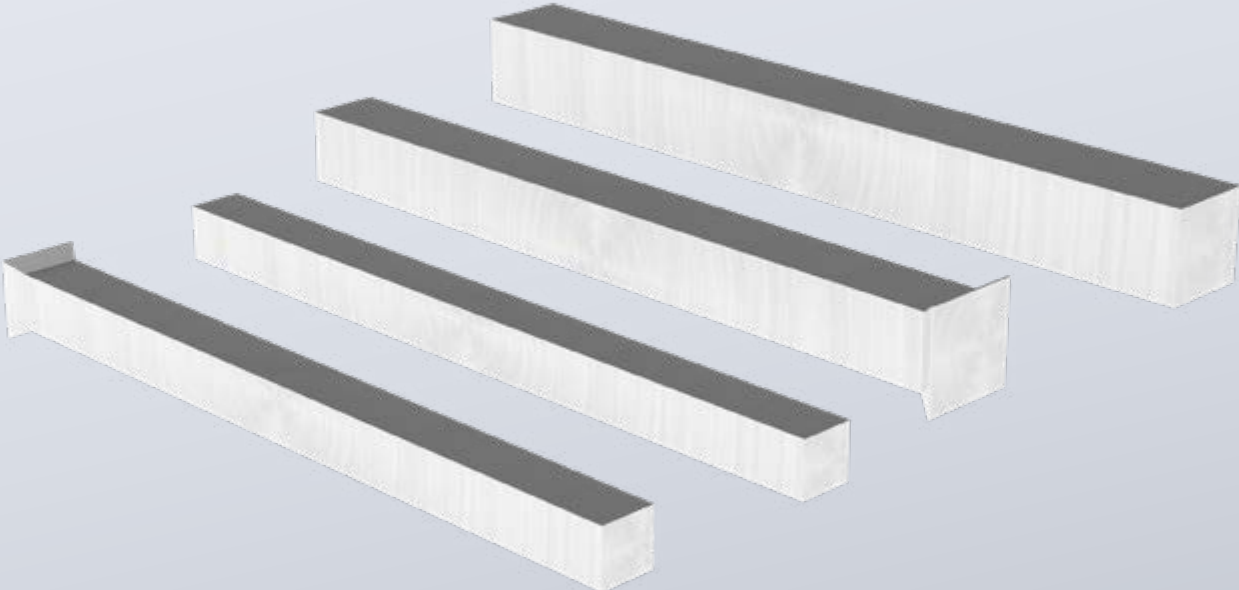

PUNCH WITHOUT HEAD, SQUARE / RECTANGULAR, SHAPE A



230.

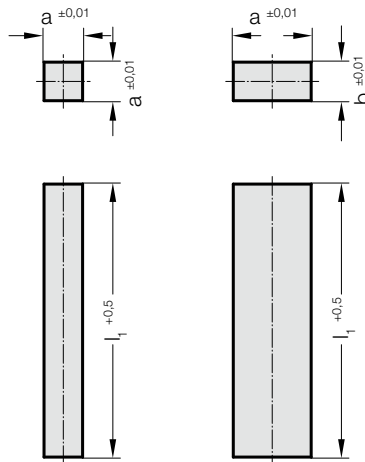

230. Punch without head, square / rectangular, Shape A

a	b	l ₁	l*
1 - 8	1	73.5	71
2 - 10	2	73.5	71
3 - 12	3	73.5	71
4 - 12	4	73.5	71
5 - 15	5	73.5	71
6 - 20	6	73.5	71
7 - 24	7	73.5	71
8 - 24	8	73.5	71
9 - 28	9	73.5	71
10 - 34	10	73.5	71
12 - 34	12	73.5	71

*l = Nominal ordering length

Material:

HSS

Order No 230.3.

Hardness:

Shaft 64 ± 2 HRC

Description of FIBRO materials for tool and die components see at the beginning of Chapter E.

Execution:

Punch shaft precision ground.

l₁: Stock length of square punches: 73,5 mm

Other materials and dimensions on request.

Ordering Code (example):

Punch without head, square / rectangular, Shape A	=	230.
Material MAT	HSS =	3.
Cutting length a	6 mm =	0600.
Cutting width b	6 mm =	0600.
Nominal order length l	71 =	071
Order No	=	230. 3.0600. 0600. 071

PUNCH WITH HEAD, SQUARE / RECTANGULAR, SHAPE B

231.

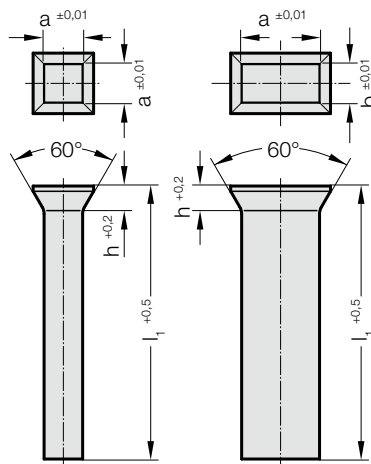

Material:

HSS
 Order No 231.3.
 Hardness:
 Shaft 64 ± 2 HRC
 Head 52 ± 3 HRC

Description of FIBRO materials for tool and die components see at the beginning of Chapter E.

Execution:

Punch shaft precision ground.
 Heads hot upset forged - ground on special request.

l_1 : Stock length of square punches: 71 mm
 Other materials and dimensions on request.

231. Punch with head, square / rectangular, Shape B

a	b	h	l_1
1 - 8	1	1.2	71
2 - 10	2	1.4	71
3 - 12	3	1.8	71
4 - 12	4	1.8	71
5 - 15	5	1.8	71
6 - 20	6	2	71
7 - 24	7	2.8	71
8 - 24	8	2.8	71
9 - 28	9	2.8	71
10 - 34	10	2.8	71
12 - 34	12	2.8	71

Ordering Code (example):

Punch with head, square / rectangular, Shape B	=	231.
Material MAT	HSS	= 3.
Cutting length a	6 mm	= 0600.
Cutting width b	6 mm	= 0600.
Length l_1	71 mm	= 071
Order No	=	231.3.0600. 0600. 071

BALL-LOCK PUNCHES

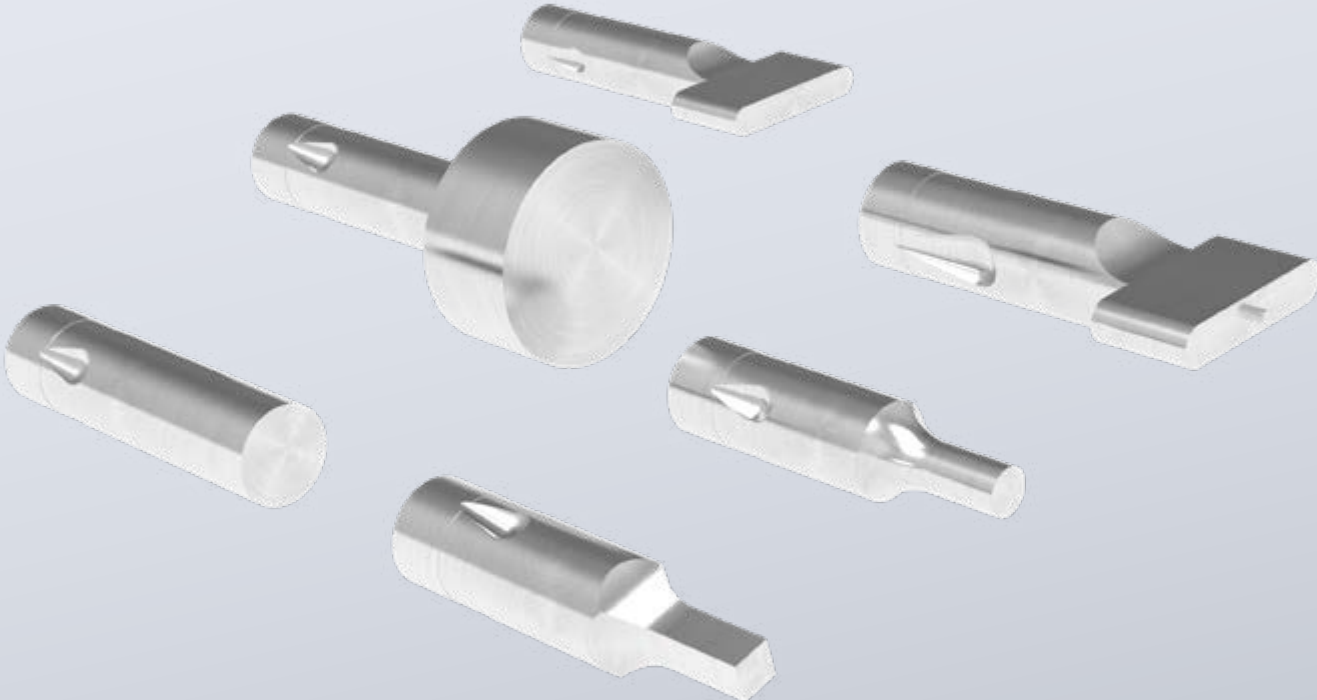

BALL-LOCK PUNCH - EXAMPLE ORDERS

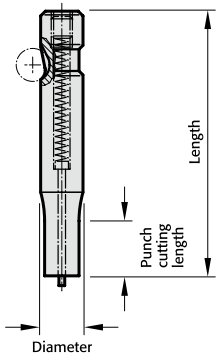

Note: See table for standard dimensions
Special dimensions to order

2 2 4 2 . 2 F 1 . 0 6 5 0 . 0 4 5 0 . B

Punch:
22 without ejector pin
27 with ejector pin

Execution:	Order No
○ blank	= 0
⊙ round	= 1
□ square	= 2
▭ rectangular	= 3
⊔ slot	= 4
▭ rectangle with radiused corners	= 5
▽ Pilot pin with tapered tip	= 6
⊔ Pilot pin parabolic tip	= 7
special shapes	= 9

Type:	Order No
light	= 2
heavy	= 3
punch larger, light	= 4
punch larger, heavy	= 5

Punch cutting length: l_1	Order No
13	= 1
19	= 2
25	= 3
30	= 4
special	= X

Format: Slot length P = 6.5 mm

Form: Slot width = 4.5 mm

Angle:	Order Code character
0°	= A
90°	= B
180°	= C
270°	= D
special	= X

Length: l	Order Code character
50	= A
56	= B
63	= C
71	= D
80	= E
90	= F
100	= G
110	= H
125	= J
140	= K
150	= L
175	= M
200	= N
special	= X

Diameter: d_2	Order No
6 (light duty only)	= 1
10	= 2
13	= 3
16	= 4
20	= 5
25	= 6
32	= 7
38 (light duty only)	= 8
40 (heavy duty only)	= 9

Ordering Code (example):

2 2 4 2 . 2 F 1 . 0 6 5 0 . 0 4 5 0 . B

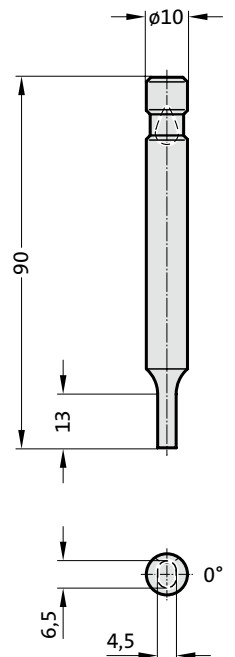
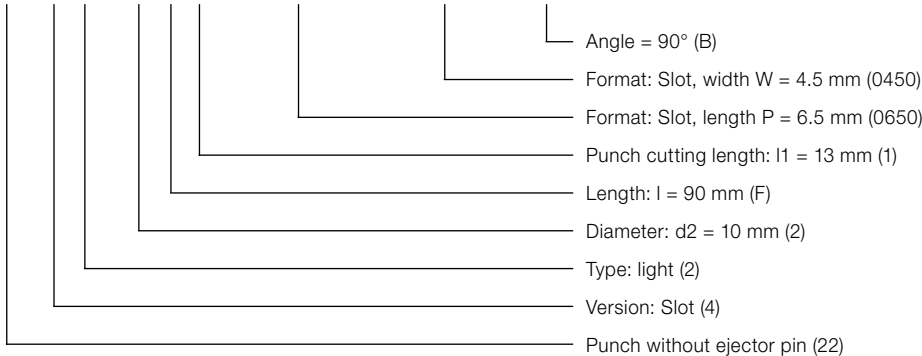

BALL-LOCK PUNCH, BLANK, LIGHT DUTY

2202.

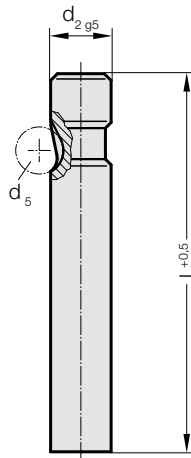

2202. Ball-Lock punch, blank, light duty

d ₂ / Order No	d ₅	l / (Order Code character)	63 (C)	71 (D)	80 (E)	90 (F)	100 (G)	110 (H)	125 (J)	140 (K)	150 (L)	175 (M)	200 (N)
6 / (1)	6		●	●	●	●	●						
10 / (2)	8		●	●	●	●	●	●					
13 / (3)	8		●	●	●	●	●	●	●	●		●	
16 / (4)	8		●	●	●	●	●	●	●	●	●	●	
20 / (5)	8		●	●	●	●	●	●	●	●	●	●	●
25 / (6)	8		●	●	●	●	●	●	●	●	●	●	●
32 / (7)	8			●	●	●	●	●	●	●	●	●	●
38 / (8)	8				●	●	●	●	●	●	●	●	●

Ordering Code (example):

2202.7G

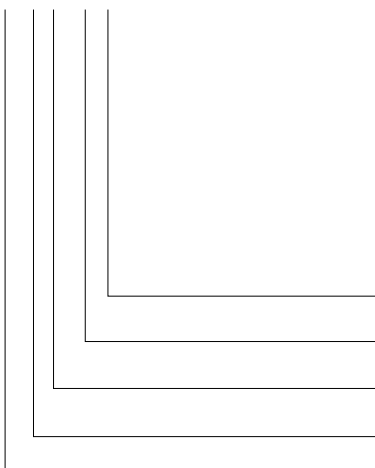

Length: l
100 mm
Diameter: d₂
32 mm
Type:
light
Execution:
blank
Punch:
without ejector pin

Order Code character
= (G)
Order No
= (7)
Order No
= (2)
Order No
= (0)
= 22

Material:

HSS
Hardness 62 ± 2 HRC

Execution:

Shaft fine ground.
Special dimensions on request.

BALL-LOCK PUNCH, STEPPED, ROUND, LIGHT DUTY



2212.

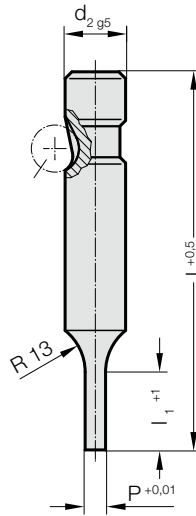

2212. Ball-Lock punch, stepped, round, light duty

d ₂ / Order No	d _s	P	l ₁ / Order No	l (Order Code character)	63 (C)	71 (D)	80 (E)	90 (F)	100 (G)
6 / (1)	6	1,6 - 5,9	13(1)		●	●	●	●	●
10 / (2)	8	1,6 - 9,9	13(1) 19(2)		●	●	●	●	●
13 / (3)	8	5 - 12,9	13(1) 19(2)		●	●	●	●	●
16 / (4)	8	8 - 15,9	13(1) 19(2) 25(3)		●	●	●	●	●
20 / (5)	8	12 - 19,9	13(1) 19(2) 25(3)		●	●	●	●	●
25 / (6)	8	16 - 24,9	13(1) 19(2) 25(3)		●	●	●	●	●
32 / (7)	8	24 - 31,9	13(1) 19(2) 25(3)			●	●	●	●
38 / (8)	8	30 - 37,9	19(2) 25(3) 30(4)				●	●	●

l₁=10 where P < 2.20

Material:

HSS
Hardness 62 ± 2 HRC

Execution:

Shaft and punch diameter fine ground.
Special dimensions on request.

Ordering Code (example):

2212.7G2.2450

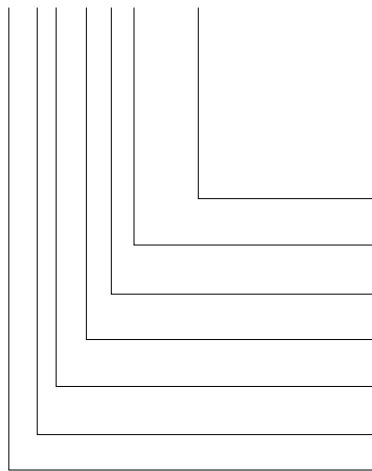

Shape: round

P = Ø 24,5 mm

Punch cutting length: l₁
19 mm

Length: l
100 mm

Diameter: d₂
32 mm

Type:
light

Execution:
round

Punch:
without ejector pin

= 2450

Order No
= (2)

Order Code character
= (G)

Order No
= (7)

Order No
= (2)

Order No
= (1)

= 22

BALL-LOCK PUNCH, STEPPED, SQUARE, LIGHT DUTY

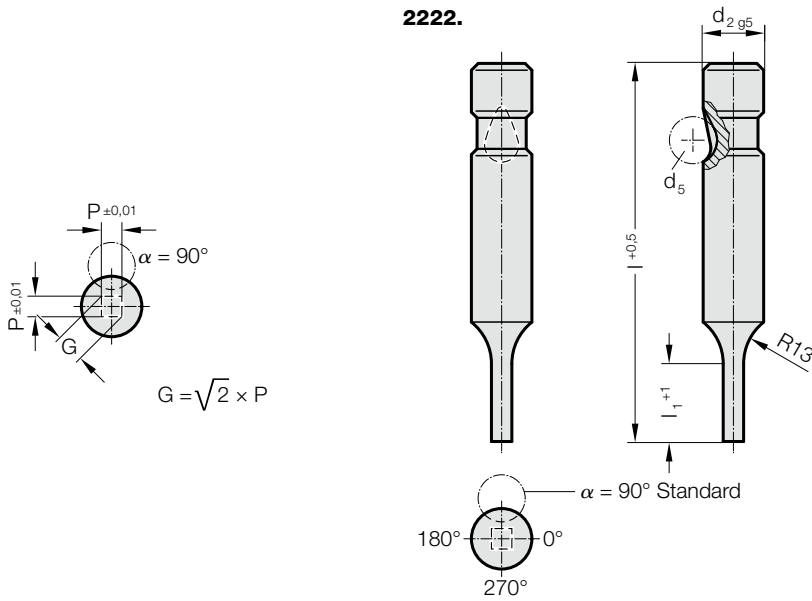

2222. Ball-Lock punch, stepped, square, light duty

d_2 / Order No	d_5	P_{min}	G_{max}	l_1 / Order No	I (Order Code character)	63	71	80	90	100
						(C)	(D)	(E)	(F)	(G)
6 / (1)	6	1.6	5.9	13(1)		●	●	●	●	●
10 / (2)	8	1.6	9.9	13(1) 19(2)		●	●	●	●	●
13 / (3)	8	4.5	12.9	13(1) 19(2)		●	●	●	●	●
16 / (4)	8	6	15.9	13(1) 19(2) 25(3)		●	●	●	●	●
20 / (5)	8	8	19.9	13(1) 19(2) 25(3)		●	●	●	●	●
25 / (6)	8	10	24.9	13(1) 19(2) 25(3)		●	●	●	●	●
32 / (7)	8	12.5	31.9	13(1) 19(2) 25(3)			●	●	●	●
38 / (8)	8	14	37.9	19(2) 25(3) 30(4)				●	●	●

$l_1 = 10$ where $P < 2.20$

Ordering Code (example):

2222.2E1.0650.A

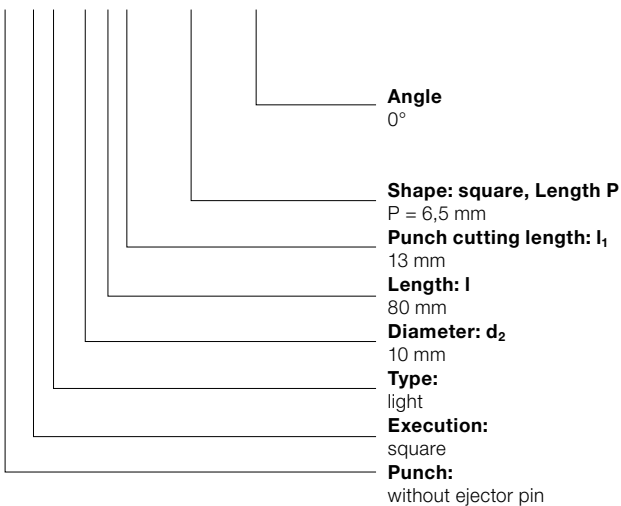

Order Code character
= (A)

= 0650

Order No
= (1)

Order Code character
= (E)

Order No
= (2)

Order No
= (2)

Order No
= (2)

= 22

Material:

HSS

Hardness 62 ± 2 HRC

Execution:

Shaft and punch shape fine ground.
Special dimensions on request.

Note:

With kerf ≤ 0.04 mm, FIBRO rounds off sharp edges if the punch and piercing die bush are ordered together. This reduces the fitting time and the risk of an edge break during operation.

BALL-LOCK PUNCH, STEPPED, RECTANGULAR, LIGHT DUTY

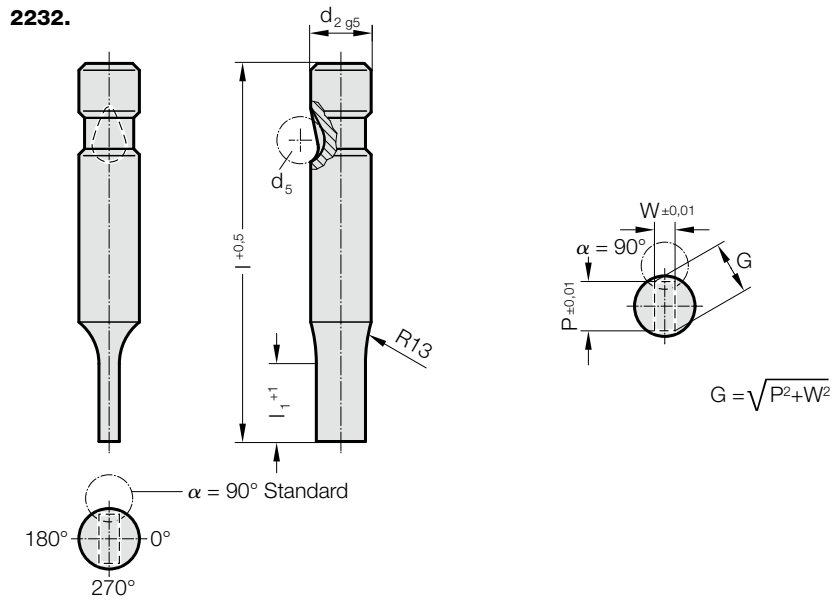

2232. Ball-Lock punch, stepped, rectangular, light duty

d ₂ / Order No	d ₅	W _{min}	G _{max}	l ₁ / Order No	l (Order Code character)	63 (C)	71 (D)	80 (E)	90 (F)	100 (G)
6 / (1)	6	1.6	5.9	13(1)		●	●	●	●	●
10 / (2)	8	1.6	9.9	13(1) 19(2)		●	●	●	●	●
13 / (3)	8	4.5	12.9	13(1) 19(2)		●	●	●	●	●
16 / (4)	8	6	15.9	13(1) 19(2) 25(3)		●	●	●	●	●
20 / (5)	8	8	19.9	13(1) 19(2) 25(3)		●	●	●	●	●
25 / (6)	8	10	24.9	13(1) 19(2) 25(3)		●	●	●	●	●
32 / (7)	8	12.5	31.9	13(1) 19(2) 25(3)			●	●	●	●
38 / (8)	8	14	37.9	19(2) 25(3) 30(4)				●	●	●

l₁=10 where W < 2.20

Material:

HSS
Hardness 62 ± 2 HRC

Execution:

Shaft and punch shape fine ground.
Special dimensions on request.

Note:

With kerf ≤ 0.04 mm, FIBRO rounds off sharp edges if the punch and piercing die bush are ordered together. This reduces the fitting time and the risk of an edge break during operation.

Ordering Code (example):

2232.2F1.0650.0450.B

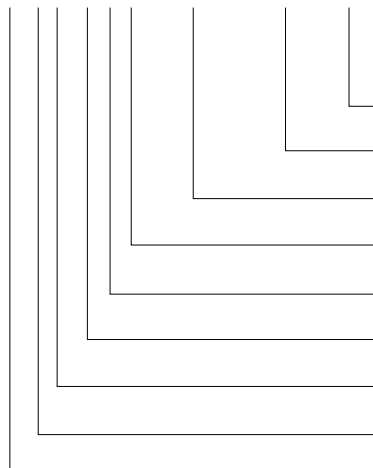

Angle
90°
Order Code character
= (B)

Shape: rectangular, Width W
W = 4,5 mm
Order Code character
= 0450

Shape: rectangular, Length P
P = 6,5 mm
Order Code character
= 0650

Punch cutting length: l₁
13 mm
Order No
= (1)

Length: l
90 mm
Order Code character
= (F)

Diameter: d₂
10 mm
Order No
= (2)

Type:
light
Order No
= (2)

Execution:
rectangular
Order No
= (3)

Punch:
without ejector pin
Order No
= 22

BALL-LOCK PUNCH, STEPPED, SLOT, LIGHT DUTY

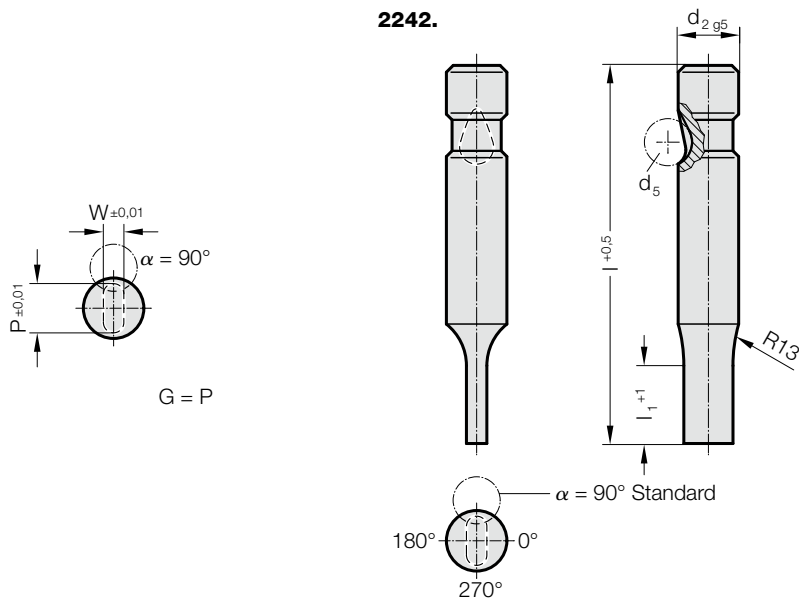

2242. Ball-Lock punch, stepped, slot, light duty

d ₂ / Order No	d ₅	W _{min}	G _{max}	l ₁ / Order No	l (Order Code character)	63	71	80	90	100
						(C)	(D)	(E)	(F)	(G)
6 / (1)	6	1.6	5.9	13(1)		●	●	●	●	●
10 / (2)	8	1.6	9.9	13(1) 19(2)		●	●	●	●	●
13 / (3)	8	4.5	12.9	13(1) 19(2)		●	●	●	●	●
16 / (4)	8	6	15.9	13(1) 19(2) 25(3)		●	●	●	●	●
20 / (5)	8	8	19.9	13(1) 19(2) 25(3)		●	●	●	●	●
25 / (6)	8	10	24.9	13(1) 19(2) 25(3)		●	●	●	●	●
32 / (7)	8	12.5	31.9	13(1) 19(2) 25(3)			●	●	●	●
38 / (8)	8	14	37.9	19(2) 25(3) 30(4)				●	●	●

l₁=10 where W < 2.20

Ordering Code (example):

2242.2F1.0650.0450.B

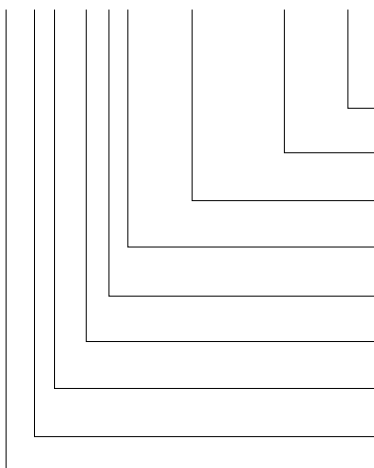

Angle:
90°
Shape: slot, Width W
W = 4,5 mm
Shape: slot, Length P
P = 6,5 mm
Punch cutting length: l₁
13 mm
Length: l
90 mm
Diameter: d₂
10 mm
Type:
light
Execution:
slot
Punch:
without ejector pin

Order Code character
= (B)
= 0450
= 0650
Order No
= (1)
Order Code character
= (F)
Order No
= (2)
Order No
= (2)
Order No
= (4)
= 22

Material:

HSS
Hardness 62 ± 2 HRC

Execution:

Shaft and punch shape fine ground.
Special dimensions on request.

BALL-LOCK PUNCH, STEPPED, RECTANGLE WITH RADIUSSED CORNERS, LIGHT DUTY



2252.

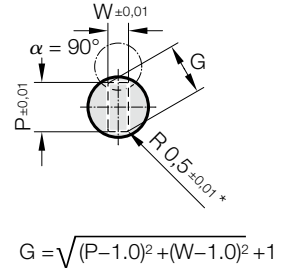
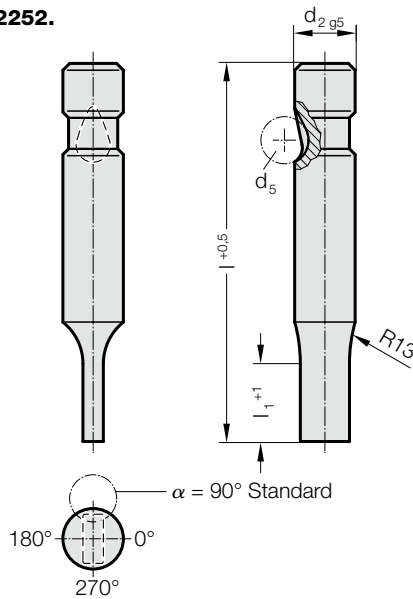

2252. Ball-Lock punch, stepped, rectangle with radiused corners, light duty

d ₂ / Order No	d ₅	W _{min}	G _{max}	l ₁ / Order No	l (Order Code character)	63 (C)	71 (D)	80 (E)	90 (F)	100 (G)
6 / (1)	6	1.6	5.9	13(1)		●	●	●	●	●
10 / (2)	8	1.6	9.9	13(1) 19(2)		●	●	●	●	●
13 / (3)	8	4.5	12.9	13(1) 19(2)		●	●	●	●	●
16 / (4)	8	6	15.9	13(1) 19(2) 25(3)		●	●	●	●	●
20 / (5)	8	8	19.9	13(1) 19(2) 25(3)		●	●	●	●	●
25 / (6)	8	10	24.9	13(1) 19(2) 25(3)		●	●	●	●	●
32 / (7)	8	12.5	31.9	13(1) 19(2) 25(3)			●	●	●	●
38 / (8)	8	14	37.9	19(2) 25(3) 30(4)				●	●	●

l₁=10 where W < 2.20

Material:

HSS
Hardness 62 ± 2 HRC

Execution:

Shaft and punch shape fine ground.
Special dimensions on request.

* For other radius options, see standardised special shapes.

Ordering Code (example):

2252.2F1.0650.0450.B

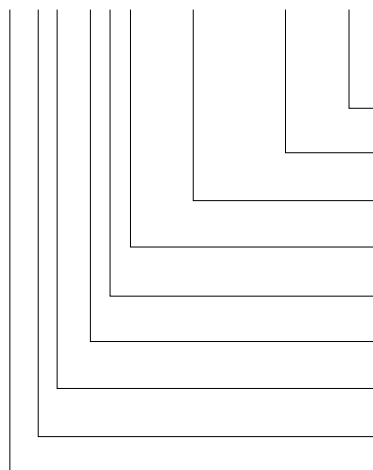

Angle: 90°
Shape: rectangle with radiused corners, Width W = 4,5 mm
Shape: rectangle with radiused corners, Length P = 6,5 mm
Punch cutting length: l₁ = 13 mm
Length: l = 90 mm
Diameter: d₂ = 10 mm
Type: light
Execution: rectangle with radiused corners
Punch: without ejector pin

Order Code character = (B)
Order Code character = (F)
Order No = (1)
Order Code character = (F)
Order No = (2)
Order No = (2)
Order No = (5)
Order No = (2)
Order No = (5)
Order No = (2)

BALL-LOCK PUNCH, BLANK, WITH EJECTOR PIN, LIGHT DUTY

2702.

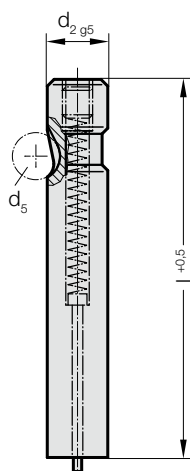

2702. Ball-Lock punch, blank, with ejector pin, light duty

d ₂ / Order No	d ₅	l / (Order Code character)	63 (C)	71 (D)	80 (E)	90 (F)	100 (G)
6 / (1)	6		●	●	●	●	●
10 / (2)	8		●	●	●	●	●
13 / (3)	8		●	●	●	●	●
16 / (4)	8		●	●	●	●	●
20 / (5)	8		●	●	●	●	●
25 / (6)	8		●	●	●	●	●
32 / (7)	8			●	●	●	●
38 / (8)	8				●	●	●

Ordering Code (example):

2702.7G

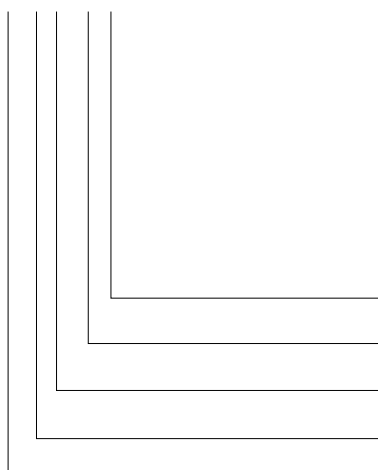

Length: l
100 mm
Diameter: d₂
32 mm
Type:
light
Execution:
blank
Punch:
with ejector pin

Order Code character
= (G)
Order No
= (7)
Order No
= (2)
Order No
= (0)
= 27

Material:

HSS
Hardness 62 ± 2 HRC

Execution:

Shaft fine ground.
Special dimensions on request.

BALL-LOCK PUNCH, STEPPED, ROUND, WITH EJECTOR PIN, LIGHT DUTY



2712.

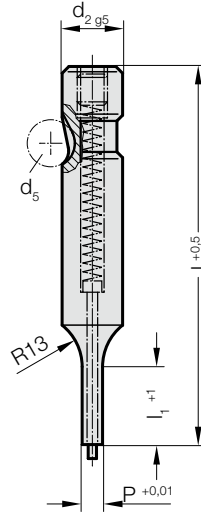

2712. Ball-Lock punch, stepped, round, with ejector pin, light duty

d ₂ / Order No	d _s	P	l ₁ / Order No	l (Order Code character)	63 (C)	71 (D)	80 (E)	90 (F)	100 (G)
6 / (1)	6	2,5 - 5,9	13(1)		●	●	●	●	●
10 / (2)	8	5 - 9,9	13(1) 19(2)		●	●	●	●	●
13 / (3)	8	6 - 12,9	13(1) 19(2)		●	●	●	●	●
16 / (4)	8	8 - 15,9	13(1) 19(2) 25(3)		●	●	●	●	●
20 / (5)	8	10 - 19,9	13(1) 19(2) 25(3)		●	●	●	●	●
25 / (6)	8	12 - 24,9	13(1) 19(2) 25(3)		●	●	●	●	●
32 / (7)	8	16 - 31,9	13(1) 19(2) 25(3)			●	●	●	●
38 / (8)	8	19 - 37,9	19(2) 25(3) 30(4)				●	●	●

Material:

HSS
Hardness 62 ± 2 HRC

Execution:

Shaft and punch diameter fine ground.
Special dimensions on request.

Ordering Code (example):

2712.7G2.2450

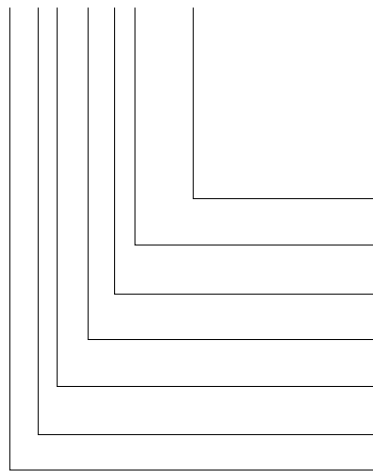

Shape: round

P = Ø 24,5 mm

Punch cutting length: l₁
19 mm

Length: l

100 mm

Diameter: d₂

32 mm

Type:

light

Execution:

round

Punch:

with ejector pin

= 2450

Order No

= (2)

Order Code character

= (G)

Order No

= (7)

Order No

= (2)

Order No

= (1)

= 27

BALL-LOCK PUNCH, STEPPED, SQUARE, WITH EJECTOR PIN, LIGHT DUTY

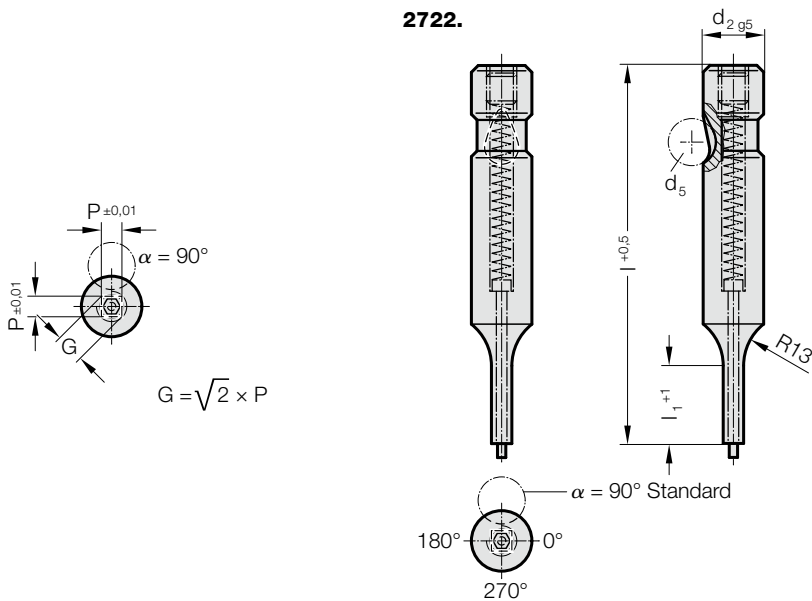

2722. Ball-Lock punch, stepped, square, with ejector pin, light duty

d_2 / Order No	d_5	P_{min}	G_{max}	l_1 / Order No	l (Order Code character)	63 (C)	71 (D)	80 (E)	90 (F)	100 (G)
6 / (1)	6	2.5	5.9	13(1)		●	●	●	●	●
10 / (2)	8	4	9.9	13(1) 19(2)		●	●	●	●	●
13 / (3)	8	6	12.9	13(1) 19(2)		●	●	●	●	●
16 / (4)	8	8	15.9	13(1) 19(2) 25(3)		●	●	●	●	●
20 / (5)	8	10	19.9	13(1) 19(2) 25(3)		●	●	●	●	●
25 / (6)	8	12	24.9	13(1) 19(2) 25(3)		●	●	●	●	●
32 / (7)	8	16	31.9	13(1) 19(2) 25(3)			●	●	●	●
38 / (8)	8	19	37.9	19(2) 25(3) 30(4)				●	●	●

Ordering Code (example):

2722.2E1.0650.A

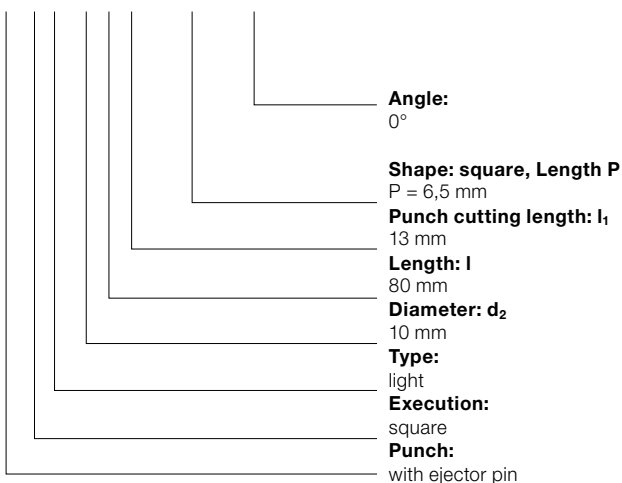

Order Code character
= (A)

= 0650

Order No
= (1)

Order Code character
= (E)

Order No
= (2)

Order No
= (2)

Order No
= (2)

= 27

Material:

HSS

Hardness 62 ± 2 HRC

Execution:

Shaft and punch shape fine ground.
Special dimensions on request.

Note:

With kerf ≤ 0.04 mm, FIBRO rounds off sharp edges if the punch and piercing die bush are ordered together. This reduces the fitting time and the risk of an edge break during operation.

BALL-LOCK PUNCH, STEPPED, RECTANGULAR, WITH EJECTOR PIN, LIGHT DUTY

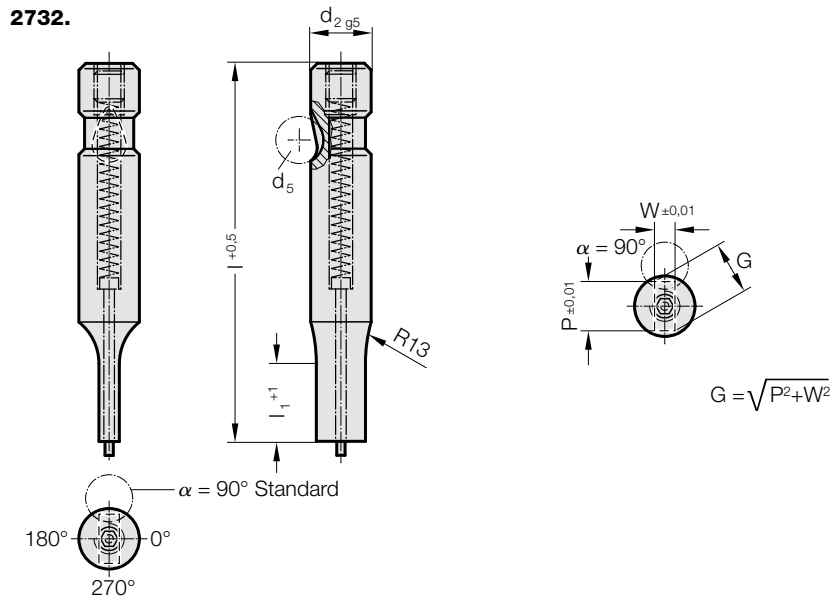

2732. Ball-Lock punch, stepped, rectangular, with ejector pin, light duty

d_2 / Order No	d_5	W_{\min}	G_{\max}	l_1 / Order No	l (Order Code character)	63 (C)	71 (D)	80 (E)	90 (F)	100 (G)
6 / (1)	6	2.5	5.9	13(1)		●	●	●	●	●
10 / (2)	8	4	9.9	13(1) 19(2)		●	●	●	●	●
13 / (3)	8	6	12.9	13(1) 19(2)		●	●	●	●	●
16 / (4)	8	8	15.9	13(1) 19(2) 25(3)		●	●	●	●	●
20 / (5)	8	10	19.9	13(1) 19(2) 25(3)		●	●	●	●	●
25 / (6)	8	12	24.9	13(1) 19(2) 25(3)		●	●	●	●	●
32 / (7)	8	16	31.9	13(1) 19(2) 25(3)			●	●	●	●
38 / (8)	8	19	37.9	19(2) 25(3) 30(4)				●	●	●

Material:

HSS
Hardness 62 ± 2 HRC

Execution:

Shaft and punch shape fine ground.
Special dimensions on request.

Note:

With kerf ≤ 0.04 mm, FIBRO rounds off sharp edges if the punch and piercing die bush are ordered together. This reduces the fitting time and the risk of an edge break during operation.

Ordering Code (example):

2732.2F1.0650.0450.B

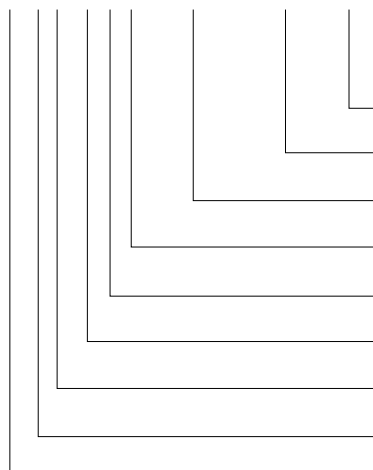

Angle:
90°

Shape: rectangular, Width W
W = 4,5 mm

Shape: rectangular, Length P
P = 6,5 mm

Punch cutting length: l_1
13 mm

Length: l
90 mm

Diameter: d_2
10 mm

Type:
light

Execution:
rectangular

Punch:
with ejector pin

Order Code character
= (B)

= 0450

= 0650

Order No
= (1)

Order Code character
= (F)

Order No
= (2)

Order No
= (2)

Order No
= (3)

= 27

BALL-LOCK PUNCH, STEPPED, SLOT, WITH EJECTOR PIN, LIGHT DUTY

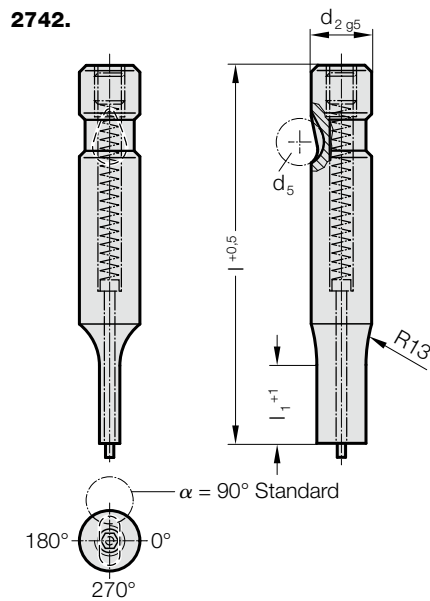

2742. Ball-Lock punch, stepped, slot, with ejector pin, light duty

d ₂ / Order No	d ₅	W _{min}	G _{max}	l ₁ / Order No	l (Order Code character)	63 (C)	71 (D)	80 (E)	90 (F)	100 (G)
6 / (1)	6	2.5	5.9	13(1)		●	●	●	●	●
10 / (2)	8	4	9.9	13(1) 19(2)		●	●	●	●	●
13 / (3)	8	6	12.9	13(1) 19(2)		●	●	●	●	●
16 / (4)	8	8	15.9	13(1) 19(2) 25(3)		●	●	●	●	●
20 / (5)	8	10	19.9	13(1) 19(2) 25(3)		●	●	●	●	●
25 / (6)	8	12	24.9	13(1) 19(2) 25(3)		●	●	●	●	●
32 / (7)	8	16	31.9	13(1) 19(2) 25(3)			●	●	●	●
38 / (8)	8	19	37.9	19(2) 25(3) 30(4)				●	●	●

Ordering Code (example):

2742.2F1.0650.0450.B

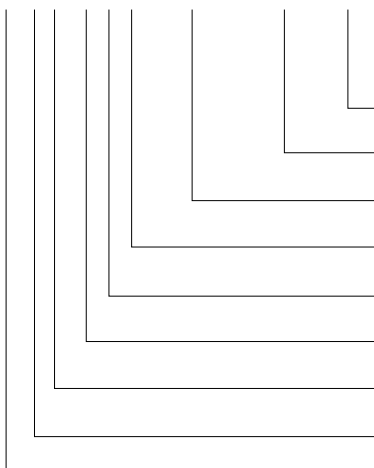

Angle:
90°
Shape: slot, Width W
W = 4,5 mm
Shape: slot, Length P
P = 6,5 mm
Punch cutting length: l₁
13 mm
Length: l
90 mm
Diameter: d₂
10 mm
Type:
light
Execution:
slot
Punch:
with ejector pin

Order Code character
= (B)
= 0450
= 0650
Order No
= (1)
Order Code character
= (F)
Order No
= (2)
Order No
= (2)
Order No
= (4)
= 27

Material:

HSS
Hardness 62 ± 2 HRC

Execution:

Shaft and punch shape fine ground.
Special dimensions on request.

BALL-LOCK PUNCH, STEPPED, RECTANGLE WITH RADIUSSED CORNERS, WITH EJECTOR PIN, LIGHT DUTY



2752.

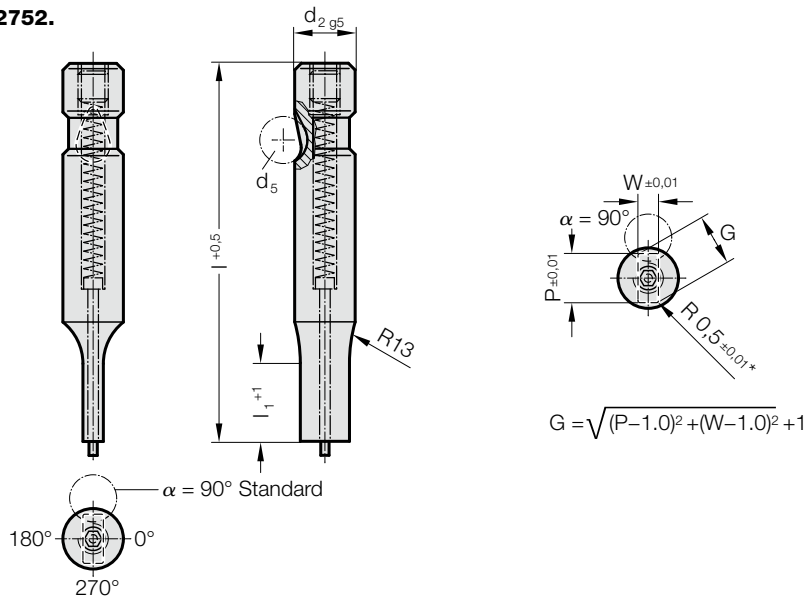

2752. Ball-Lock punch, stepped, rectangle with radiussed corners, with ejector pin, light duty

d ₂ / Order No	d ₅	W _{min}	G _{max}	l ₁ / Order No	l (Order Code character)	63 (C)	71 (D)	80 (E)	90 (F)	100 (G)
6 / (1)	6	2.5	5.9	13(1)		●	●	●	●	●
10 / (2)	8	4	9.9	13(1) 19(2)		●	●	●	●	●
13 / (3)	8	6	12.9	13(1) 19(2)		●	●	●	●	●
16 / (4)	8	8	15.9	13(1) 19(2) 25(3)		●	●	●	●	●
20 / (5)	8	10	19.9	13(1) 19(2) 25(3)		●	●	●	●	●
25 / (6)	8	12	24.9	13(1) 19(2) 25(3)		●	●	●	●	●
32 / (7)	8	16	31.9	13(1) 19(2) 25(3)		●	●	●	●	●
38 / (8)	8	19	37.9	19(2) 25(3) 30(4)				●	●	●

Material:

HSS
Hardness 62 ± 2 HRC

Execution:

Shaft and punch shape fine ground.
Special dimensions on request.
* For other radius options, see standardised special shapes.

Ordering Code (example):

2752.2F1.0650.0450.B

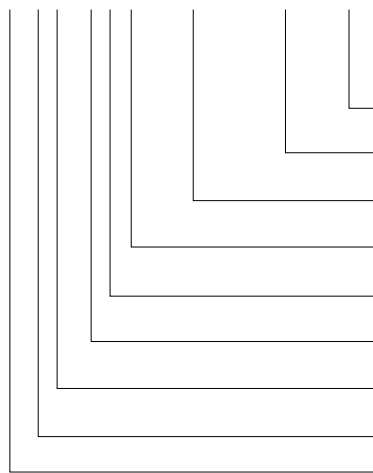

Angle: 90°
Shape: rectangle with radiussed corners, Width W = 4,5 mm
Shape: rectangle with radiussed corners, Length P = 6,5 mm
Punch cutting length: l₁ = 13 mm
Length: l = 90 mm
Diameter: d₂ = 10 mm
Type: light
Execution: rectangle with radiussed corners
Punch: with ejector pin

Order Code character = (B)
Order Code character = (F)
Order No = (1)
Order Code character = (F)
Order No = (2)
Order No = (2)
Order No = (5)
Order No = (27)

BALL-LOCK PUNCH, PUNCH LARGER THAN SHAFT, BLANK, LIGHT DUTY

2204.

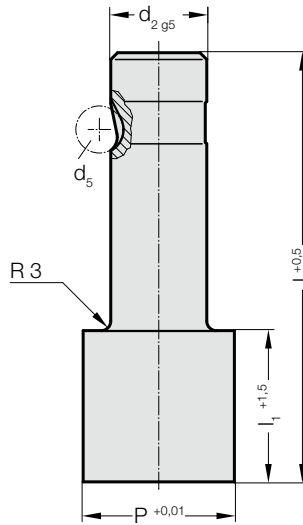
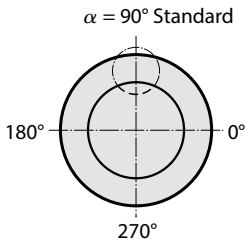

2204. Ball-Lock punch, punch larger than shaft, blank, light duty

d ₂ / Order No	d ₅	P	l ₁ / Order No	l (Order Code character)	80 (E)	90 (F)	100 (G)
13 / (3)	8	32	19 / (2) 30 / (4)		●	●	●
16 / (4)	8	38	19 / (2) 30 / (4)		●	●	●
20 / (5)	8	40	19 / (2) 30 / (4)		●	●	●
25 / (6)	8	44	19 / (2) 30 / (4)		●	●	●
32 / (7)	8	50	19 / (2) 30 / (4)		●	●	●

Ordering Code (example):

2204.4F4.3800

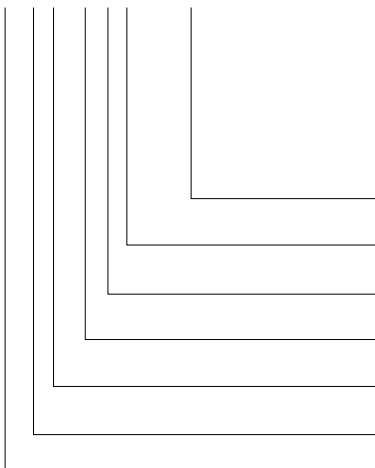

Shape: round

P = Ø 38 mm

Punch cutting length: l₁
30 mm

Length: l
90 mm

Diameter: d₂
16 mm

Type:
punch larger, light

Execution:
blank

Punch:
without ejector pin

= 3800

Order No
= (4)

Order Code character
= (F)

Order No
= (4)

Order No
= (4)

Order No
= (0)

= 22

Material:

HSS

Hardness 62 ± 2 HRC

Execution:

Shaft and punch diameter fine ground.
Special dimensions on request.

BALL-LOCK PUNCH, PUNCH LARGER THAN SHAFT, ROUND, LIGHT DUTY



2214.

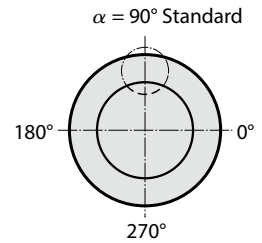
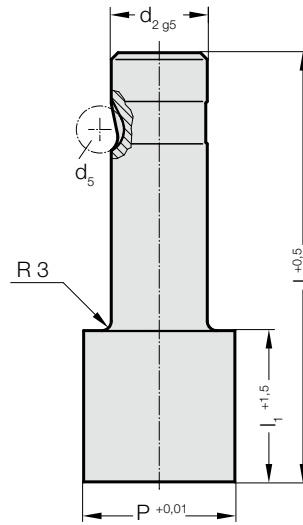

2214. Ball-Lock punch, punch larger than shaft, round, light duty

d ₂ / Order No	d ₅	P	l ₁ / Order No	I / (Order Code character)	80 (E)	90 (F)	100 (G)
13 / (3)	8	13,1 - 32	19(2) 30(4)		●	●	●
16 / (4)	8	16,1 - 38	19(2) 30(4)		●	●	●
20 / (5)	8	20,1 - 40	19(2) 30(4)		●	●	●
25 / (6)	8	25,1 - 44	19(2) 30(4)		●	●	●
32 / (7)	8	32,1 - 50	19(2) 30(4)		●	●	●

Material:

HSS
Hardness 62 ± 2 HRC

Execution:

Shaft and punch diameter fine ground.
Special dimensions on request.

Ordering Code (example):

2214.7G2.3820

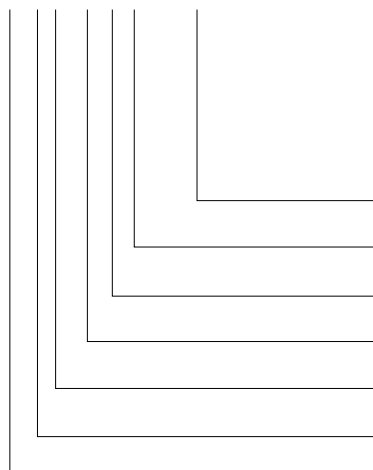

Shape: round

P = Ø 38,2 mm

Punch cutting length: l₁
19 mm

Length: I
100 mm

Diameter: d₂
32 mm

Type:
punch larger, light

Execution:

round

Punch:
without ejector pin

= 3820

Order No
= (2)

Order Code character
= (G)

Order No
= (7)

Order No
= (4)

Order No
= (1)

= 22

BALL-LOCK PUNCH, PUNCH LARGER THAN SHAFT, SQUARE, LIGHT DUTY

2224.

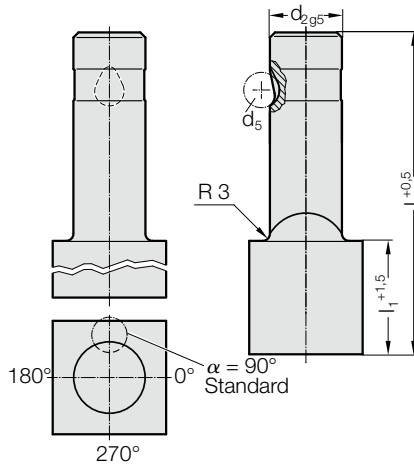
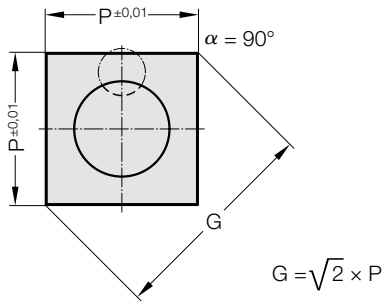

2224. Ball-Lock punch, punch larger than shaft, square, light duty

d_2 / Order No	d_5	P_{min}	G_{max}	l_1 / Order No	l (Order Code character)	80 (E)	90 (F)	100 (G)
13 / (3)	8	9.19	32	19(2) 30(4)		●	●	●
16 / (4)	8	11.31	38	19(2) 30(4)		●	●	●
20 / (5)	8	14.14	40	19(2) 30(4)		●	●	●
25 / (6)	8	17.68	44	19(2) 30(4)		●	●	●
32 / (7)	8	22.63	50	19(2) 30(4)		●	●	●

Ordering Code (example):

2224.7F2.3535.A

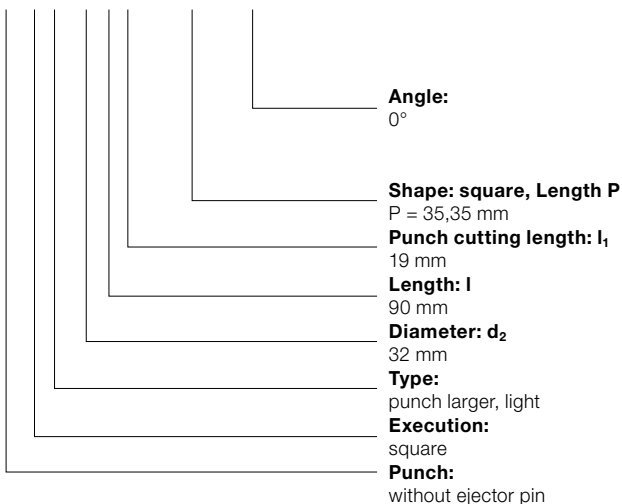

Order Code character
= (A)

= 3535

Order No
= (2)

Order Code character
= (F)

Order No
= (7)

Order No
= (4)

Order No
= (2)

= 22

Material:

HSS

Hardness 62 ± 2 HRC

Execution:

Shaft and punch shape fine ground.
Special dimensions on request.

Note:

With kerf ≤ 0.04 mm, FIBRO rounds off sharp edges if the punch and piercing die bush are ordered together. This reduces the fitting time and the risk of an edge break during operation.

BALL-LOCK PUNCH, PUNCH LARGER THAN SHAFT, RECTANGULAR, LIGHT DUTY



2234.

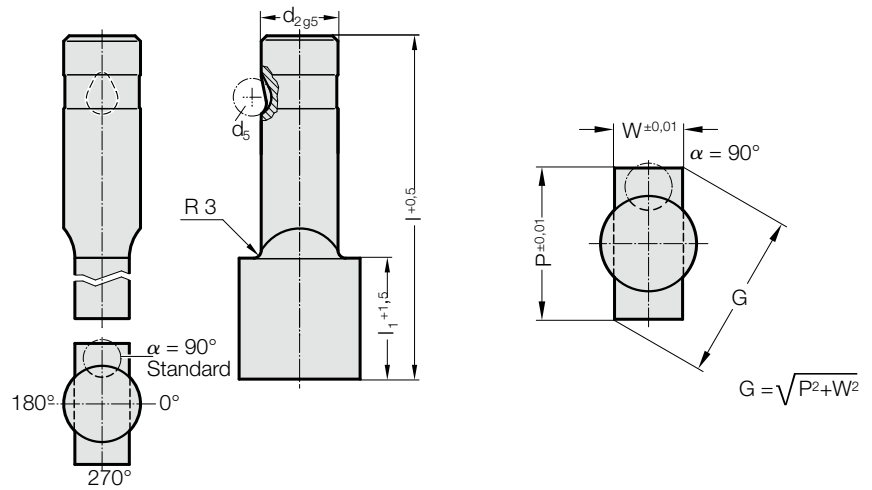

2234. Ball-Lock punch, punch larger than shaft, rectangular, light duty

d ₂ / Order No	d ₅	W _{min}	G _{max}	l ₁ / Order No	l (Order Code character)	80	90	100
						(E)	(F)	(G)
13 / (3)	8	5	32	19(2) 30(4)		●	●	●
16 / (4)	8	6.5	38	19(2) 30(4)		●	●	●
20 / (5)	8	8	40	19(2) 30(4)		●	●	●
25 / (6)	8	10	44	19(2) 30(4)		●	●	●
32 / (7)	8	11.5	50	19(2) 30(4)		●	●	●

Material:

HSS
Hardness 62 ± 2 HRC

Execution:

Shaft and punch shape fine ground.
Special dimensions on request.

Note:

With kerf ≤ 0.04 mm, FIBRO rounds off sharp edges if the punch and piercing die bush are ordered together. This reduces the fitting time and the risk of an edge break during operation.

Ordering Code (example):

2234.7F2.3820.1150.B

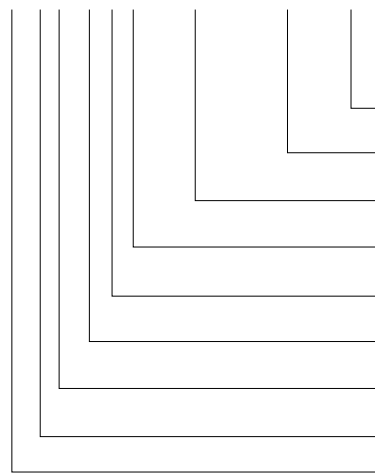

Angle:
90°

Shape: rectangular, Width W
W = 11,5 mm

Shape: rectangular, Length P
P = 38,2 mm

Punch cutting length: l₁
19 mm

Length: l
90 mm

Diameter: d₂
32 mm

Type:
punch larger, light

Execution:
rectangular

Punch:
without ejector pin

Order Code character
= (B)

= 1150

= 3820

Order No
= (2)

Order Code character
= (F)

Order No
= (7)

Order No
= (4)

Order No
= (3)

= 22

BALL-LOCK PUNCH, PUNCH LARGER THAN SHAFT, SLOT, LIGHT DUTY

2244.

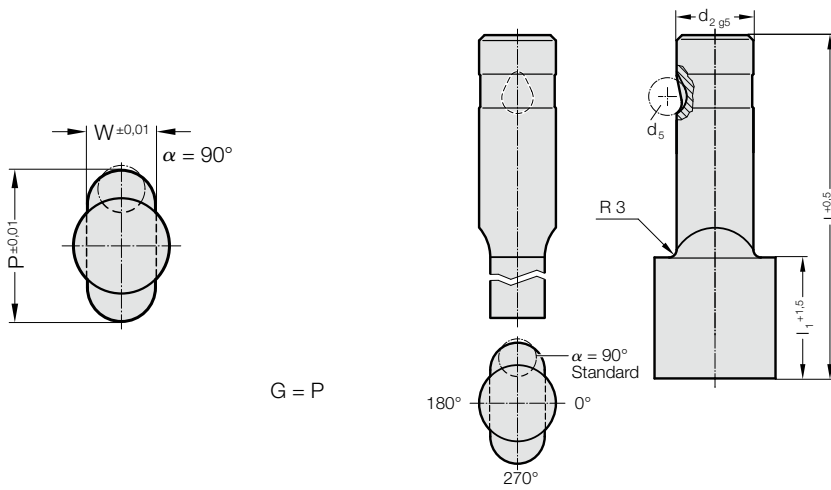

2244. Ball-Lock punch, punch larger than shaft, slot, light duty

d ₂ / Order No	d ₅	W _{min}	G _{max}	l ₁ / Order No	l (Order Code character)	80	90	100
						(E)	(F)	(G)
13 / (3)	8	5	32	19(2) 30(4)		●	●	●
16 / (4)	8	6.5	38	19(2) 30(4)		●	●	●
20 / (5)	8	8	40	19(2) 30(4)		●	●	●
25 / (6)	8	10	44	19(2) 30(4)		●	●	●
32 / (7)	8	11.5	50	19(2) 30(4)		●	●	●

Ordering Code (example):

2244.4F2.3720.1150.B

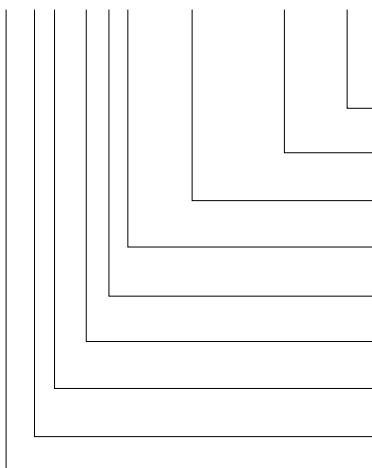

Angle:
90°
Shape: slot, Width W
W = 11,5 mm
Shape: slot, Length P
P = 37,2 mm
Punch cutting length: l₁
19 mm
Length: l
90 mm
Diameter: d₂
16 mm
Type:
punch larger, light
Execution:
slot
Punch:
without ejector pin

Order Code character
= (B)
= 1150
= 3720
Order No
= (2)
Order Code character
= (F)
Order No
= (4)
Order No
= (4)
Order No
= (4)

Material:

HSS
Hardness 62 ± 2 HRC

Execution:

Shaft and punch shape fine ground.
Special dimensions on request.

BALL-LOCK PUNCH, PUNCH LARGER THAN SHAFT, RECTANGLE WITH RADIUSSED CORNERS, LIGHT DUTY



2254.

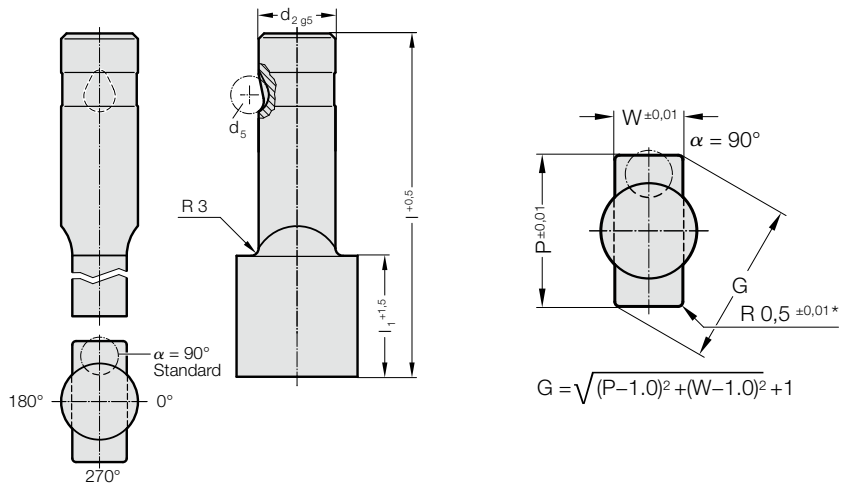

2254. Ball-Lock punch, punch larger than shaft, rectangle with radiussed corners, light duty

d ₂ / Order No	d ₅	W _{min}	G _{max}	l ₁ / Order No	l (Order Code character)	80 (E)	90 (F)	100 (G)
13 / (3)	8	5	32	19(2) 30(4)		●	●	●
16 / (4)	8	6.5	38	19(2) 30(4)		●	●	●
20 / (5)	8	8	40	19(2) 30(4)		●	●	●
25 / (6)	8	10	44	19(2) 30(4)		●	●	●
32 / (7)	8	11.5	50	19(2) 30(4)		●	●	●

Material:

HSS
Hardness 62 ± 2 HRC

Execution:

Shaft and punch shape fine ground.
Special dimensions on request.
* For other radius options, see standardised special shapes.

Ordering Code (example):

2254.7F2.3720.1150.B

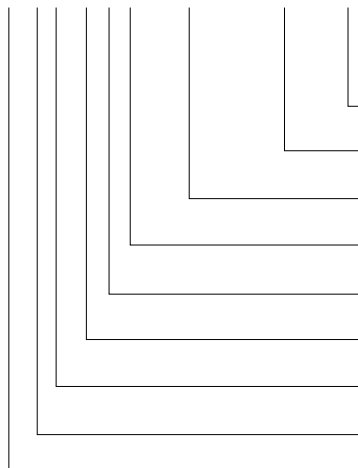

Angle: 90°
Order Code character = (B)
Shape: rectangle with radiused corners, Width W = 11,5 mm
Order Code character = (F)
Shape: rectangle with radiused corners, Length P = 37,2 mm
Order No = (2)
Punch cutting length: l₁ 19 mm
Order Code character = (F)
Length: l 90 mm
Order No = (7)
Diameter: d₂ 32 mm
Order No = (4)
Type: punch larger, light
Order No = (5)
Execution: rectangle with radiused corners
Punch: without ejector pin

BALL-LOCK PUNCH, PUNCH LARGER THAN SHAFT, BLANK, WITH EJECTOR PIN, LIGHT DUTY

2704.

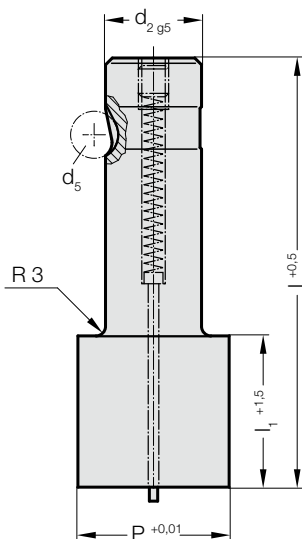
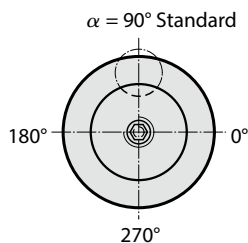

2704. Ball-Lock punch, punch larger than shaft, blank, with ejector pin, light duty

d ₂ / Order No	d ₅	P	l ₁ / Order No	I (Order Code character)	80 (E)	90 (F)	100 (G)
13 / (3)	8	32	19(2) 30(4)		●	●	●
16 / (4)	8	38	19(2) 30(4)		●	●	●
20 / (5)	8	40	19(2) 30(4)		●	●	●
25 / (6)	8	44	19(2) 30(4)		●	●	●
32 / (7)	8	50	19(2) 30(4)		●	●	●

Ordering Code (example):

2704.4F4.3800

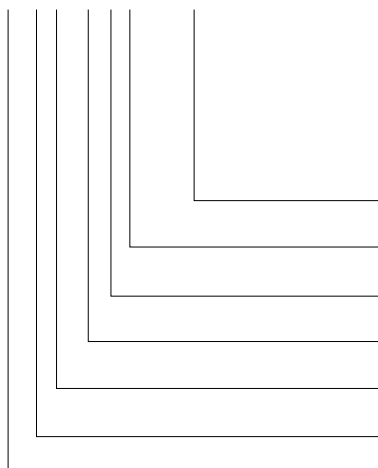

Shape: round

P = Ø 38 mm

Punch cutting length: l₁

30 mm

Length: I

90 mm

Diameter: d₂

16 mm

Type:

punch larger, light

Execution:

blank

Punch:

with ejector pin

= 3800

Order No

= (4)

Order Code character

= (F)

Order No

= (4)

Order No

= (4)

Order No

= (0)

= 27

Material:

HSS

Hardness 62 ± 2 HRC

Execution:

Shaft and punch diameter fine ground.

Special dimensions on request.

BALL-LOCK PUNCH, PUNCH LARGER THAN SHAFT, ROUND, WITH EJECTOR PIN, LIGHT DUTY



2714.

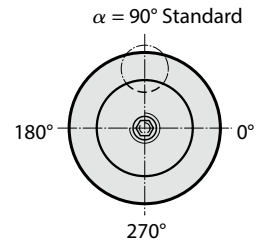
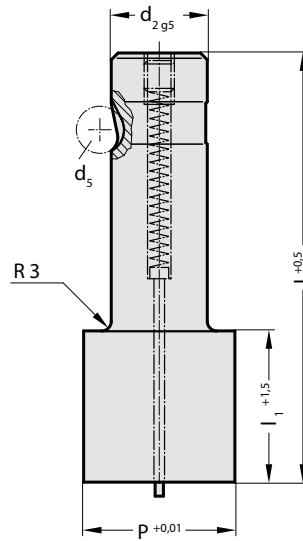

2714. Ball-Lock punch, punch larger than shaft, round, with ejector pin, light duty

d ₂ / Order No	d ₅	P	l ₁ / Order No	l (Order Code character)	80 (E)	90 (F)	100 (G)
13 / (3)	8	13,1 - 32	19(2) 30(4)		●	●	●
16 / (4)	8	16,1 - 38	19(2) 30(4)		●	●	●
20 / (5)	8	20,1 - 40	19(2) 30(4)		●	●	●
25 / (6)	8	25,1 - 44	19(2) 30(4)		●	●	●
32 / (7)	8	32,1 - 50	19(2) 30(4)		●	●	●

Material:

HSS
Hardness 62 ± 2 HRC

Execution:

Shaft and punch diameter fine ground.
Special dimensions on request.

Ordering Code (example):

2714.7G2.4250

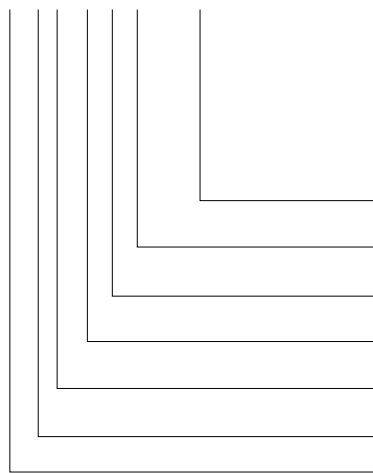

Shape: round

P = Ø 42,5 mm

Punch cutting length: l₁
19 mm

Length: l
100 mm

Diameter: d₂
32 mm

Type:
punch larger, light

Execution:
round

Punch:
with ejector pin

= 4250

Order No
= (2)

Order Code character
= (G)

Order No
= (7)

Order No
= (4)

Order No
= (1)

= 27

BALL-LOCK PUNCH, PUNCH LARGER THAN SHAFT, SQUARE, WITH EJECTOR PIN, LIGHT DUTY

2724.

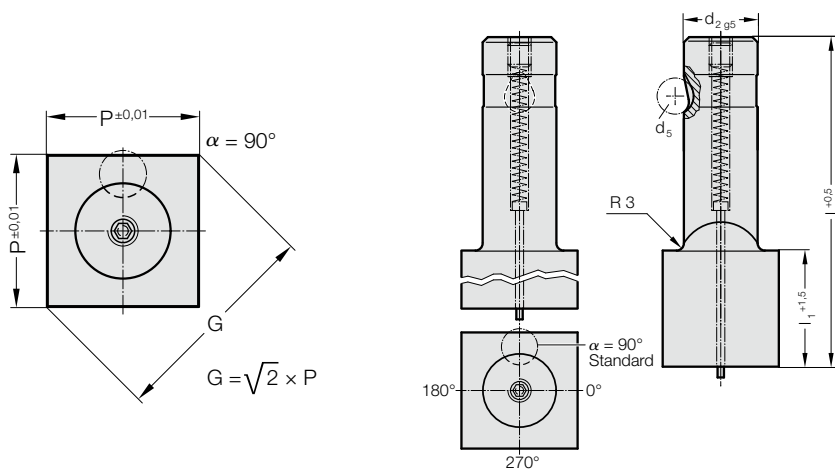

2724. Ball-Lock punch, punch larger than shaft, square, with ejector pin, light duty

d ₂ / Order No	d ₅	P _{min}	G _{max}	l ₁ / Order No	l (Order Code character)	80 (E)	90 (F)	100 (G)
13 / (3)	8	9.19	32	19(2) 30(4)		●	●	●
16 / (4)	8	11.31	38	19(2) 30(4)		●	●	●
20 / (5)	8	14.14	40	19(2) 30(4)		●	●	●
25 / (6)	8	17.68	44	19(2) 30(4)		●	●	●
32 / (7)	8	22.63	50	19(2) 30(4)		●	●	●

Ordering Code (example):

2724.5E2.2828.A

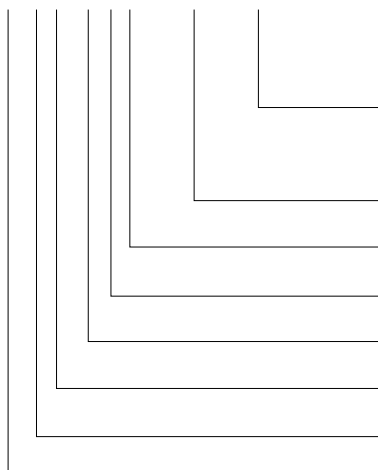

Angle:
0°

Shape: square, Length P
P = 28,28 mm

Punch cutting length: l₁
19 mm

Length: l
80 mm

Diameter: d₂
20 mm

Type:
punch larger, light

Execution:
square

Punch:
with ejector pin

Order Code character
= (A)

= 2828

Order No
= (2)

Order Code character
= (E)

Order No
= (5)

Order No
= (4)

Order No
= (2)

= 27

Material:

HSS

Hardness 62 ± 2 HRC

Execution:

Shaft and punch shape fine ground.
Special dimensions on request.

Note:

With kerf ≤ 0.04 mm, FIBRO rounds off sharp edges if the punch and piercing die bush are ordered together. This reduces the fitting time and the risk of an edge break during operation.

BALL-LOCK PUNCH, PUNCH LARGER THAN SHAFT, RECTANGULAR, WITH EJECTOR PIN, LIGHT DUTY



2734.

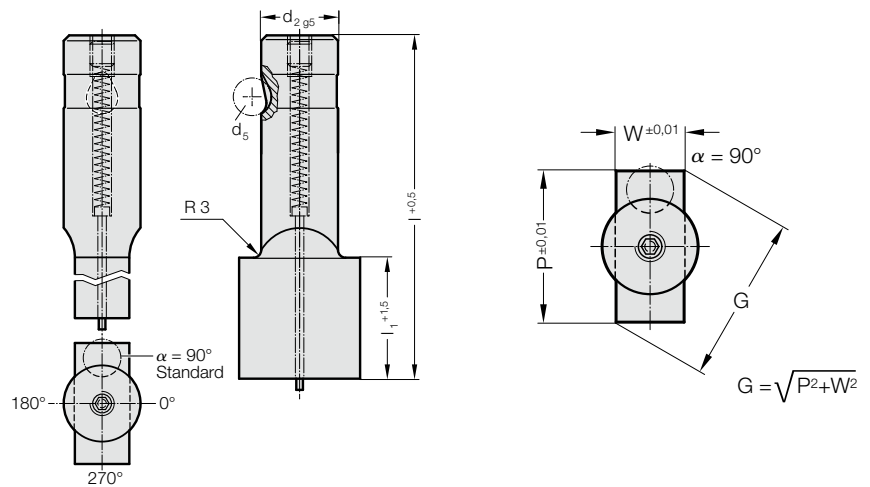

2734. Ball-Lock punch, punch larger than shaft, rectangular, with ejector pin, light duty

d ₂ / Order No	d ₅	W _{min}	G _{max}	l ₁ / Order No	l (Order Code character)	80 (E)	90 (F)	100 (G)
13 / (3)	8	5	32	19(2) 30(4)		●	●	●
16 / (4)	8	6.5	38	19(2) 30(4)		●	●	●
20 / (5)	8	8	40	19(2) 30(4)		●	●	●
25 / (6)	8	10	44	19(2) 30(4)		●	●	●
32 / (7)	8	11.5	50	19(2) 30(4)		●	●	●

Material:

HSS
Hardness 62 ± 2 HRC

Execution:

Shaft and punch shape fine ground.
Special dimensions on request.

Note:

With kerf ≤ 0.04 mm, FIBRO rounds off sharp edges if the punch and piercing die bush are ordered together. This reduces the fitting time and the risk of an edge break during operation.

Ordering Code (example):

2734.7F2.3820.1150.B

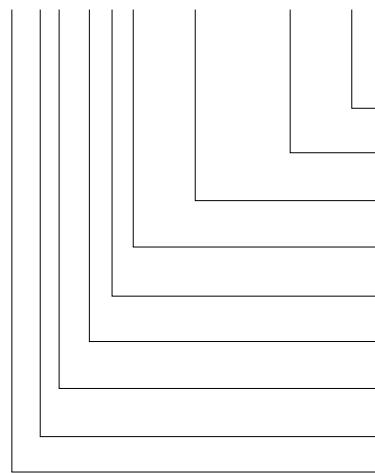

Angle:
90°

Shape: rectangular, Width W
W = 11,5 mm

Shape: rectangular, Length P
P = 38,2 mm

Punch cutting length: l₁
19 mm

Length: l
90 mm

Diameter: d₂
32 mm

Type:
punch larger, light

Execution:
rectangular

Punch:
with ejector pin

Order Code character
= (B)

= 1150

= 3820

Order No
= (2)

Order Code character
= (F)

Order No
= (7)

Order No
= (4)

Order No
= (3)

= 27

BALL-LOCK PUNCH, PUNCH LARGER THAN SHAFT, SLOT, WITH EJECTOR PIN, LIGHT DUTY

2744.

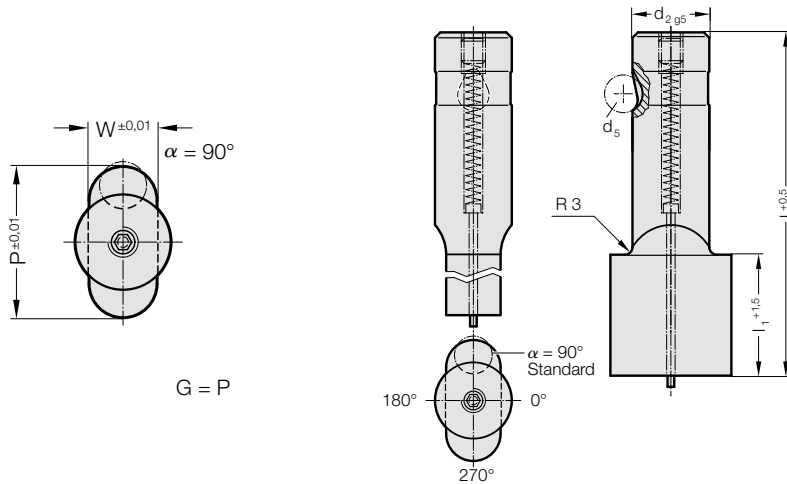

2744. Ball-Lock punch, punch larger than shaft, slot, with ejector pin, light duty

d ₂ / Order No	d ₅	W _{min}	G _{max}	l ₁ / Order No	l (Order Code character)	80	90	100
						(E)	(F)	(G)
13 / (3)	8	5	32	19(2) 30(4)		●	●	●
16 / (4)	8	6.5	38	19(2) 30(4)		●	●	●
20 / (5)	8	8	40	19(2) 30(4)		●	●	●
25 / (6)	8	10	44	19(2) 30(4)		●	●	●
32 / (7)	8	11.5	50	19(2) 30(4)		●	●	●

Ordering Code (example):

2744.7F2.3820.1150.B

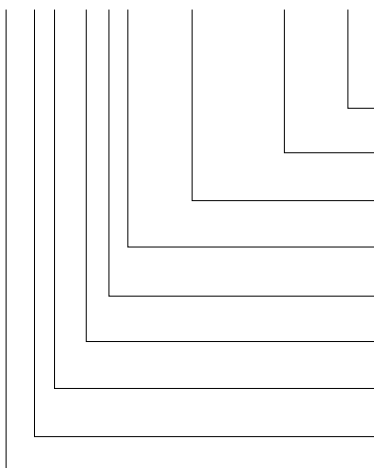

Angle:
90°
Shape: slot, Width W
W = 11,5 mm
Shape: slot, Length P
P = 38,2 mm
Punch cutting length: l₁
19 mm
Length: l
90 mm
Diameter: d₂
32 mm
Type:
punch larger, light
Execution:
slot
Punch:
with ejector pin

Order Code character
= (B)
= 1150
= 3820
Order No
= (2)
Order Code character
= (F)
Order No
= (7)
Order No
= (4)
Order No
= (4)
= 27

Material:

HSS
Hardness 62 ± 2 HRC

Execution:

Shaft and punch shape fine ground.
Special dimensions on request.

BALL-LOCK PUNCH, PUNCH LARGER THAN SHAFT, RECTANGLE WITH RADIUSSED CORNERS, WITH EJECTOR PIN, LIGHT DUTY



2754.

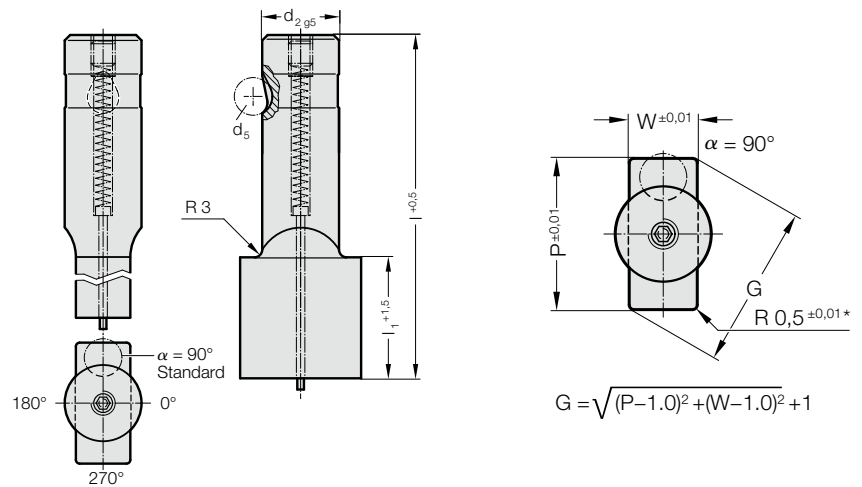

2754. Ball-Lock punch, punch larger than shaft, rectangle with radiussed corners, with ejector pin, light duty

d_2 / Order No	d_5	W_{min}	G_{max}	l_1 / Order No	l (Order Code character)	80 (E)	90 (F)	100 (G)
13 / (3)	8	5	32	19(2) 30(4)		●	●	●
16 / (4)	8	6.5	38	19(2) 30(4)		●	●	●
20 / (5)	8	8	40	19(2) 30(4)		●	●	●
25 / (6)	8	10	44	19(2) 30(4)		●	●	●
32 / (7)	8	11.5	50	19(2) 30(4)		●	●	●

Material:

HSS
Hardness 62 ± 2 HRC

Execution:

Shaft and punch shape fine ground.
Special dimensions on request.

* For other radius options, see standardised special shapes.

Ordering Code (example):

2754.7F2.3820.1150.B

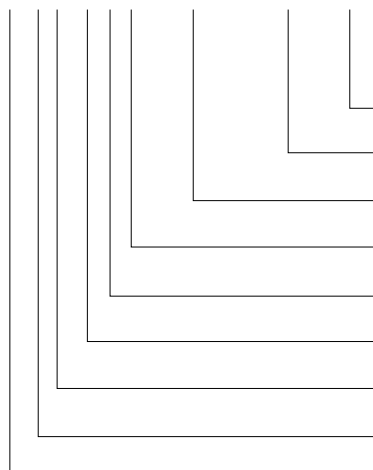

Angle:

90°

Shape: rectangle with radiussed corners, Width W
W = 11,5 mm

Shape: rectangle with radiussed corners, Length P
P = 38,2 mm

Punch cutting length: l_1
19 mm

Length: l

90 mm

Diameter: d_2

32 mm

Type:

punch larger, light

Execution:

rectangle with radiussed corners

Punch:

with ejector pin

Order Code character
= (B)

Order Code character
= (1150)

Order Code character
= (3820)

Order No
= (2)

Order Code character
= (F)

Order No
= (7)

Order No
= (4)

Order No
= (5)

= 27

BALL-LOCK PILOT PIN, WITH TAPERED TIP, LIGHT DUTY

2262.

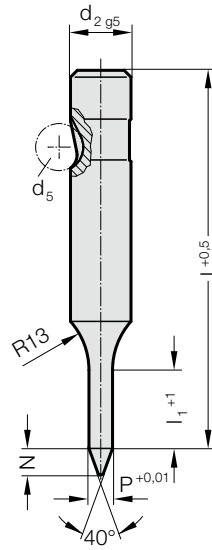

2262. Ball-Lock pilot pin, with tapered tip, light duty

d ₂ / Order No	d ₅	P	l ₁ / Order No	N	I (Order Code character)	71 (D)	80 (E)	90 (F)	100 (G)	110 (H)	125 (J)	140 (K)	150 (L)
10 / (2)	8	5,9 - 9,9	19(2)	8		●	●	●	●	●			
13 / (3)	8	9,9 - 12,9	19(2)	10		●	●	●	●	●	●		
16 / (4)	8	12,9 - 15,9	25(3)	15		●	●	●	●	●	●	●	●
20 / (5)	8	15,9 - 19,9	25(3)	20		●	●	●	●	●	●	●	●
25 / (6)	8	19,9 - 24,9	25(3)	25		●	●	●	●	●	●	●	●
32 / (7)	8	24,9 - 31,9	25(3)	30			●	●	●	●	●	●	●
38 / (8)	8	31,9 - 37,9	30(4)	35			●	●	●	●	●	●	●

Ordering Code (example):

2262.4G3.1410

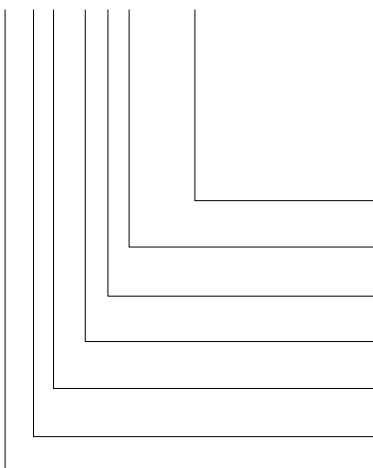

Shape: round

P = Ø 14,1 mm

Punch cutting length: l₁
25 mm

Length: I
100 mm

Diameter: d₂
16 mm

Type:
light

Execution:
Pilot pin with tapered tip

Punch:
without ejector pin

= 1410

Order No
= (3)

Order Code character
= (G)

Order No
= (4)

Order No
= (2)

Order No
= (6)

= 22

Material:

HSS

Hardness 62 ± 2 HRC

Execution:

Shaft and pilot pin fine ground.

Special dimensions on request.

BALL-LOCK PILOT PIN, WITH PARABOLIC TIP, LIGHT DUTY



2272.

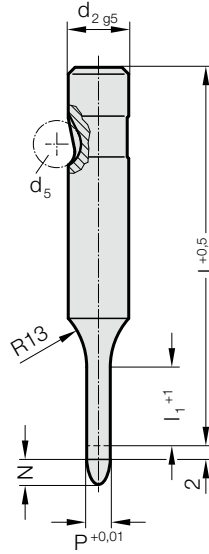

2272. Ball-Lock pilot pin, with parabolic tip, light duty

d ₂ / Order No	d ₅	P	l ₁ / Order No	l (Order Code character)	50 (A)	56 (B)	63 (C)	71 (D)	80 (E)	90 (F)	100 (G)
6 / (1)	6	2,5 - 5,9	13(1)		●	●	●	●	●	●	●
10 / (2)	8	5,9 - 9,9	19(2)		●	●	●	●	●	●	●
13 / (3)	8	9,9 - 12,9	19(2)		●	●	●	●	●	●	●
16 / (4)	8	12,9 - 15,9	25(3)				●	●	●	●	●
20 / (5)	8	15,9 - 19,9	25(3)				●	●	●	●	●
25 / (6)	8	19,9 - 24,9	25(3)				●	●	●	●	●
32 / (7)	8	24,9 - 31,9	25(3)					●	●	●	●
38 / (8)	8	31,9 - 37,9	30(4)						●	●	●

Material:

HSS
Hardness 62 ± 2 HRC

Execution:

Shaft and pilot pin fine ground.
Special dimensions on request.

Note:

The 2 mm length provides full guidance before the blanking punch contacts the sheet metal.

Length of parabolic tip N:

= 8 mm where P ≤ 10 mm
= 12 mm where P 10,1 mm - 15 mm
= 15 mm where P > 15 mm

Ordering Code (example):

2272.4G3.1410

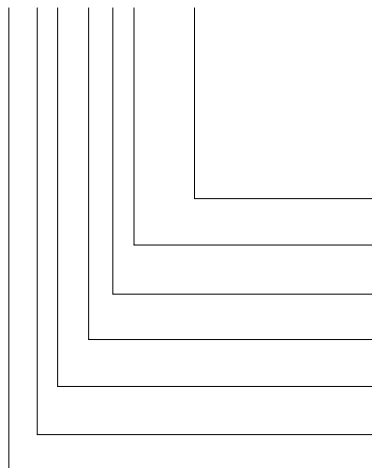

Shape: round

P = Ø 14,1 mm

Punch cutting length: l₁
25 mm

Length: l

100 mm

Diameter: d₂

16 mm

Type:

light

Execution:

Pilot pin with parabolic tip

Punch:

without ejector pin

= 1410

Order No

= (3)

Order Code character

= (G)

Order No

= (4)

Order No

= (2)

Order No

= (7)

= 22

BALL-LOCK PUNCH, BLANK, HEAVY DUTY

2203.

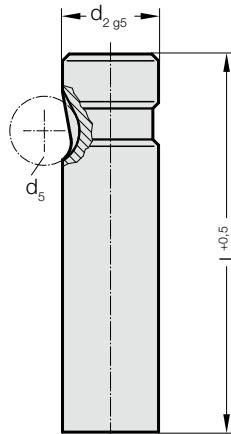

2203. Ball-Lock punch, blank, heavy duty

d ₂ / Order No	d ₅	l / (Order Code character)	63 (C)	71 (D)	80 (E)	90 (F)	100 (G)	110 (H)	125 (J)	140 (K)	150 (L)	175 (M)	200 (N)
10 / (2)	10		●	●	●	●	●	●	●				
13 / (3)	12		●	●	●	●	●	●	●	●	●	●	
16 / (4)	12		●	●	●	●	●	●	●	●	●	●	●
20 / (5)	12		●	●	●	●	●	●	●	●	●	●	●
25 / (6)	12			●	●	●	●	●	●	●	●	●	●
32 / (7)	12			●	●	●	●	●	●	●	●	●	●
40 / (9)	12				●	●	●	●	●	●	●	●	●

Ordering Code (example):

2203.7G

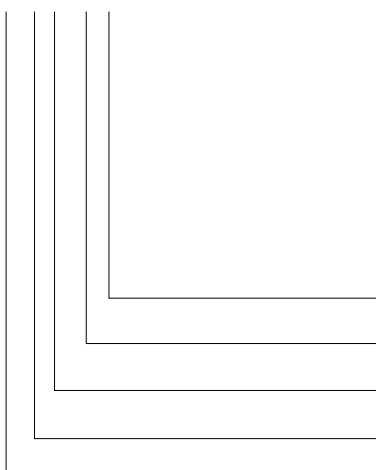

Length: l
100 mm
Diameter: d₂
32 mm
Type:
heavy
Execution:
blank
Punch:
without ejector pin

Order Code character
= (G)
Order No
= (7)
Order No
= (3)
Order No
= (0)
= 22

Material:

HSS
Hardness 62 ± 2 HRC

Execution:

Shaft fine ground.
Special dimensions on request.

BALL-LOCK PUNCH, STEPPED, ROUND, HEAVY DUTY



2213.

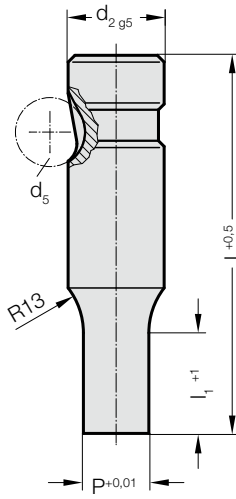

2213. Ball-Lock punch, stepped, round, heavy duty

d ₂ / Order No	d ₅	P	l ₁ / Order No	I (Order Code character)	63 (C)	71 (D)	80 (E)	90 (F)	100 (G)	110 (H)	125 (J)
10 / (2)	10	1,6 - 9,9	13(1) 19(2)		●	●	●	●	●	●	●
13 / (3)	12	5 - 12,9	13(1) 19(2)		●	●	●	●	●	●	●
16 / (4)	12	8 - 15,9	13(1) 19(2) 25(3)		●	●	●	●	●	●	●
20 / (5)	12	12 - 19,9	13(1) 19(2) 25(3)		●	●	●	●	●	●	●
25 / (6)	12	16 - 24,9	13(1) 19(2) 25(3)			●	●	●	●	●	●
32 / (7)	12	24 - 31,9	13(1) 19(2) 25(3)			●	●	●	●	●	●
40 / (9)	12	30 - 39,9	19(2) 25(3) 30(4)				●	●	●	●	●

l₁=10 where P < 2.20

Material:

HSS
Hardness 62 ± 2 HRC

Execution:

Shaft and punch diameter fine ground.
Special dimensions on request.

Ordering Code (example):

2213.7G2.2450

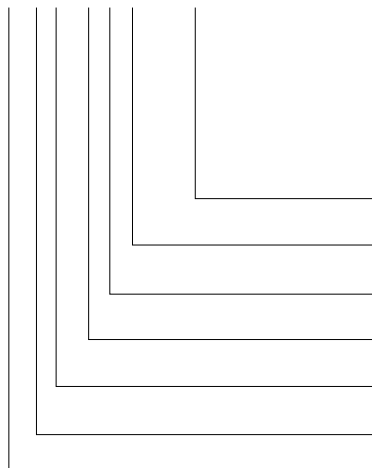

Shape: round

P = Ø 24,5 mm

Punch cutting length: l₁

19 mm

Length: I

100 mm

Diameter: d₂

32 mm

Type:

heavy

Execution:

round

Punch:

without ejector pin

= 2450

Order No

= (2)

Order Code character

= (G)

Order No

= (7)

Order No

= (3)

Order No

= (1)

= 22

BALL-LOCK PUNCH, STEPPED, SQUARE, HEAVY DUTY

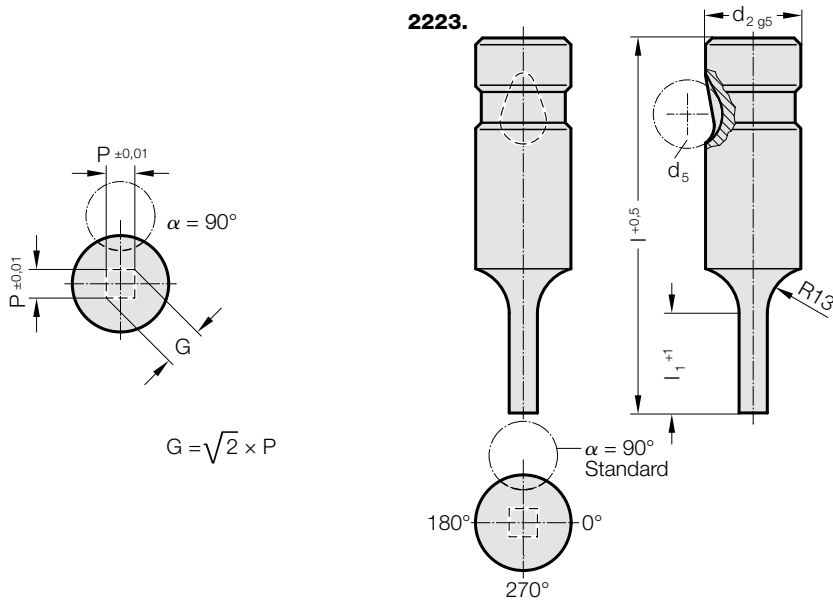

2223. Ball-Lock punch, stepped, square, heavy duty

d ₂ / Order No	d ₅	P _{min}	G _{max}	l ₁ / Order No	l (Order Code character)	63 (C)	71 (D)	80 (E)	90 (F)	100 (G)	110 (H)	125 (J)
10 / (2)	10	1.6	9.9	13(1) 19(2)		●	●	●	●	●	●	●
13 / (3)	12	4.5	12.9	13(1) 19(2)		●	●	●	●	●	●	●
16 / (4)	12	6	15.9	13(1) 19(2) 25(3)		●	●	●	●	●	●	●
20 / (5)	12	8	19.9	13(1) 19(2) 25(3)		●	●	●	●	●	●	●
25 / (6)	12	10	24.9	13(1) 19(2) 25(3)			●	●	●	●	●	●
32 / (7)	12	12.5	31.9	13(1) 19(2) 25(3)			●	●	●	●	●	●
40 / (9)	12	14	39.9	19(2) 25(3) 30(4)				●	●	●	●	●

l₁=10 where P < 2.20

Ordering Code (example):

2223.3F1.0620.B

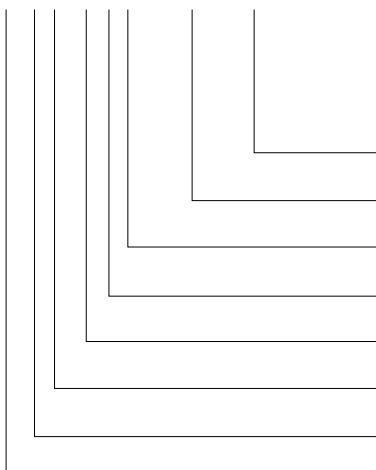

Angle:
90°
Shape: square, Length P
P = 6,2 mm
Punch cutting length: l₁
13 mm
Length: l
90 mm
Diameter: d₂
13 mm
Type:
heavy
Execution:
square
Punch:
without ejector pin

Order Code character
= (B)
Order No
= 0620
Order Code character
= (F)
Order No
= (3)
Order No
= (3)
Order No
= (2)

Material:

HSS
Hardness 62 ± 2 HRC

Execution:

Shaft and punch shape fine ground.
Special dimensions on request.

Note:

With kerf ≤ 0.04 mm, FIBRO rounds off sharp edges if the punch and piercing die bush are ordered together. This reduces the fitting time and the risk of an edge break during operation.

BALL-LOCK PUNCH, STEPPED, RECTANGULAR, HEAVY DUTY

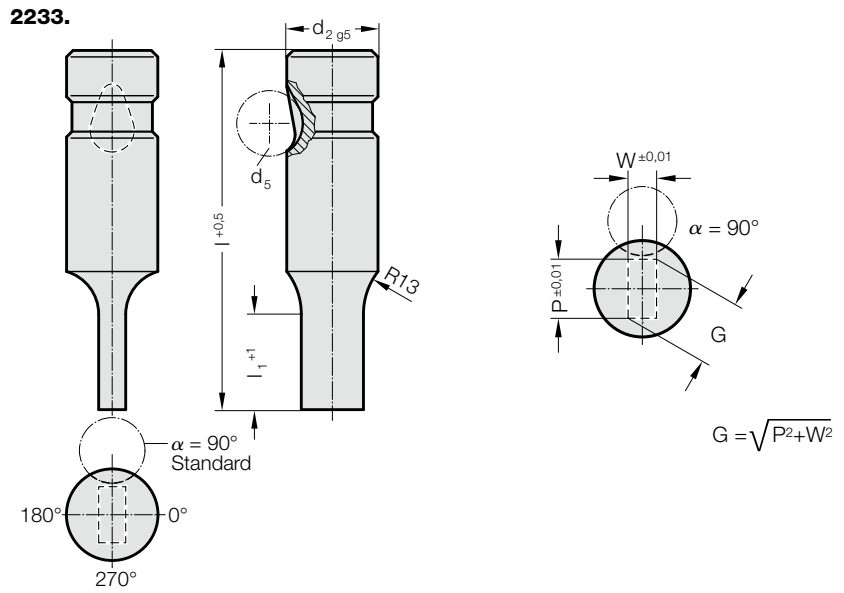

2233. Ball-Lock punch, stepped, rectangular, heavy duty

d ₂ / Order No	d ₅	W _{min}	G _{max}	l ₁ / Order No	l (Order Code character)	63 (C)	71 (D)	80 (E)	90 (F)	100 (G)	110 (H)	125 (J)
10 / (2)	10	1.6	9.9	13(1) 19(2)		●	●	●	●	●	●	●
13 / (3)	12	4.5	12.9	13(1) 19(2)		●	●	●	●	●	●	●
16 / (4)	12	6	15.9	13(1) 19(2) 25(3)		●	●	●	●	●	●	●
20 / (5)	12	8	19.9	13(1) 19(2) 25(3)		●	●	●	●	●	●	●
25 / (6)	12	10	24.9	13(1) 19(2) 25(3)			●	●	●	●	●	●
32 / (7)	12	12.5	31.9	13(1) 19(2) 25(3)			●	●	●	●	●	●
40 / (9)	12	14	39.9	19(2) 25(3) 30(4)				●	●	●	●	●

l₁=10 where W < 2.20

Material:

HSS

Hardness 62 ± 2 HRC

Execution:

Shaft and punch shape fine ground.
Special dimensions on request.

Note:

With kerf ≤ 0.04 mm, FIBRO rounds off sharp edges if the punch and piercing die bush are ordered together. This reduces the fitting time and the risk of an edge break during operation.

Ordering Code (example):

2233.2F1.0650.0450.B

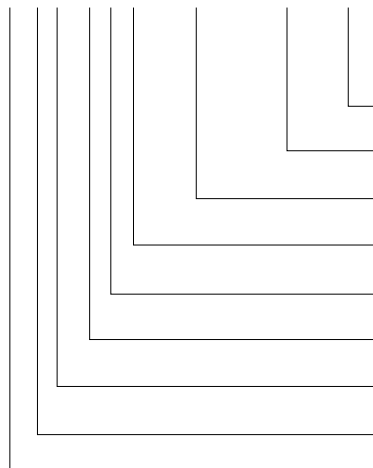

Angle:

90°

Shape: rectangular, Width W

W = 4,5 mm

Shape: rectangular, Length P

P = 6,5 mm

Punch cutting length: l₁

13 mm

Length: l

90 mm

Diameter: d₂

10 mm

Type:

heavy

Execution:

rectangular

Punch:

without ejector pin

Order Code character
= (B)

= 0450

= 0650

Order No

= (1)

Order Code character

= (F)

Order No

= (2)

Order No

= (3)

Order No

= (3)

= 22

BALL-LOCK PUNCH, STEPPED, RECTANGLE WITH RADIUSSED CORNERS, HEAVY DUTY

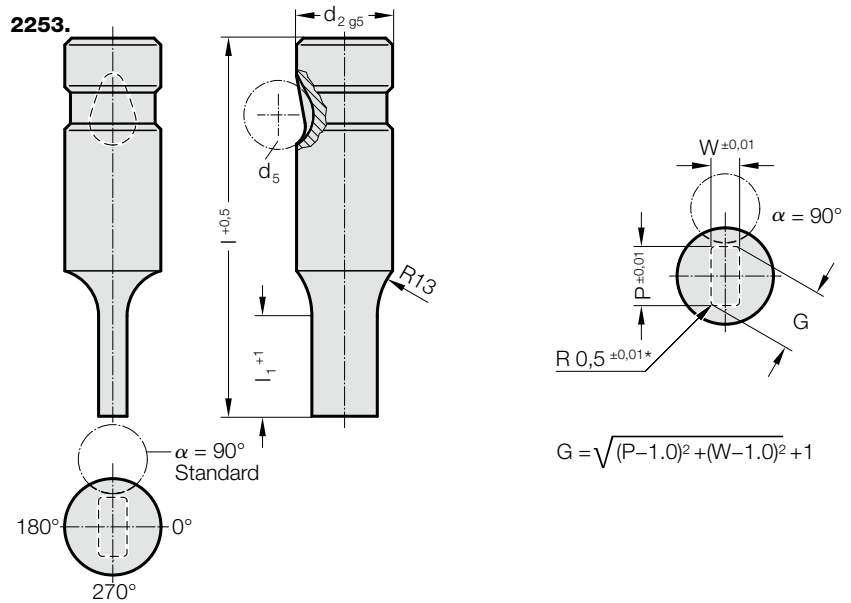

2253. Ball-Lock punch, stepped, rectangle with radiussed corners, heavy duty

d ₂ / Order No	W _{min}	G _{max}	l ₁ / Order No	l (Order Code character)	63 (C)	71 (D)	80 (E)	90 (F)	100 (G)	110 (H)	125 (J)
10 / (2)	1.6	9.9	13(1) 19(2)		●	●	●	●	●	●	●
13 / (3)	4.5	12.9	13(1) 19(2)		●	●	●	●	●	●	●
16 / (4)	6	15.9	13(1) 19(2) 25(3)		●	●	●	●	●	●	●
20 / (5)	8	19.9	13(1) 19(2) 25(3)		●	●	●	●	●	●	●
25 / (6)	10	24.9	13(1) 19(2) 25(3)			●	●	●	●	●	●
32 / (7)	12.5	31.9	13(1) 19(2) 25(3)			●	●	●	●	●	●
40 / (9)	14	39.9	19(2) 25(3) 30(4)				●	●	●	●	●

l₁=10 where W < 2.20

Material:

HSS
Hardness 62 ± 2 HRC

Execution:

Shaft and punch shape fine ground.
Special dimensions on request.

* For other radius options, see standardised special shapes.

Ordering Code (example):

2253.2F1.0650.0450.B

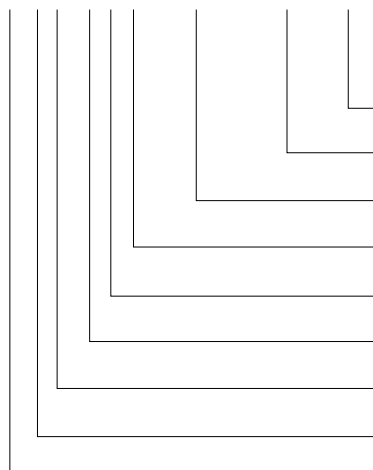

Angle: 90°
Shape: rectangle with radiused corners, Width W
W = 4,5 mm
Shape: rectangle with radiused corners, Length P
P = 6,5 mm
Punch cutting length: l₁
13 mm
Length: l
90 mm
Diameter: d₂
10 mm
Type: heavy
Execution: rectangle with radiused corners
Punch: without ejector pin

Order Code character
= (B)
Order Code character
= (F)
Order Code character
= (2)
Order Code character
= (3)
Order Code character
= (5)

BALL-LOCK PUNCH, BLANK, WITH EJECTOR PIN, HEAVY DUTY

2703.

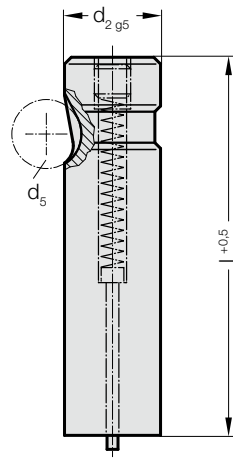

2703. Ball-Lock punch, blank, with ejector pin, heavy duty

d ₂ / Order No	d ₅	l / (Order Code character)	63 (C)	71 (D)	80 (E)	90 (F)	100 (G)	110 (H)	125 (J)
10 / (2)	10		●	●	●	●	●		
13 / (3)	12		●	●	●	●	●	●	●
16 / (4)	12		●	●	●	●	●	●	●
20 / (5)	12		●	●	●	●	●	●	●
25 / (6)	12			●	●	●	●	●	●
32 / (7)	12			●	●	●	●	●	●
40 / (9)	12				●	●	●	●	●

Ordering Code (example):

2703.7G

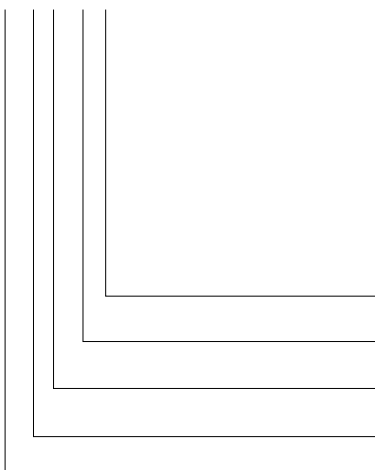

Length: l
100 mm
Diameter: d₂
32 mm
Type:
heavy
Execution:
blank
Punch:
with ejector pin

Order Code character
= (G)
Order No
= (7)
Order No
= (3)
Order No
= (0)
Order No
= (27)

Material:

HSS
Hardness 62 ± 2 HRC

Execution:

Shaft fine ground.
Special dimensions on request.

BALL-LOCK PUNCH, STEPPED, ROUND, WITH EJECTOR PIN, HEAVY DUTY



2713.

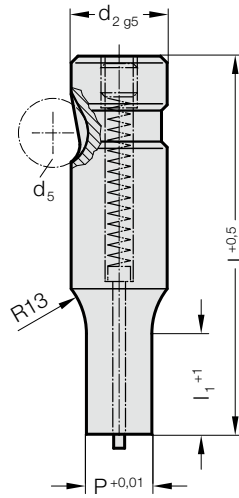

2713. Ball-Lock punch, stepped, round, with ejector pin, heavy duty

d ₂ / Order No	d ₅	P	l ₁ / Order No	l (Order Code character)	63 (C)	71 (D)	80 (E)	90 (F)	100 (G)	110 (H)	125 (J)
10 / (2)	10	5 - 9,9	13(1) 19(2)		●	●	●	●	●		
13 / (3)	12	6 - 12,9	13(1) 19(2)		●	●	●	●	●	●	●
16 / (4)	12	8 - 15,9	13(1) 19(2) 25(3)		●	●	●	●	●	●	●
20 / (5)	12	10 - 19,9	13(1) 19(2) 25(3)		●	●	●	●	●	●	●
25 / (6)	12	12 - 24,9	13(1) 19(2) 25(3)			●	●	●	●	●	●
32 / (7)	12	16 - 31,9	13(1) 19(2) 25(3)			●	●	●	●	●	●
40 / (9)	12	19 - 39,9	19(2) 25(3) 30(4)				●	●	●	●	●

*at d₂ = 16/ 20 and l = 63; l_{1 max.} = 19

Material:

HSS
Hardness 62 ± 2 HRC

Execution:

Shaft and punch diameter fine ground.
Special dimensions on request.

Ordering Code (example):

2713.3C1.0550

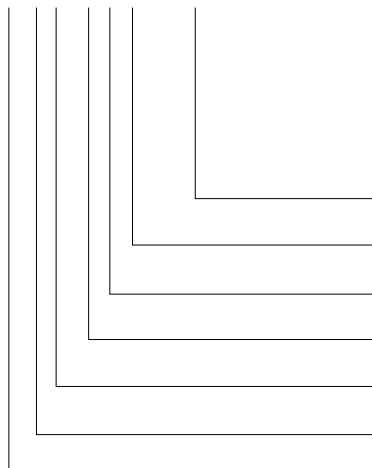

Shape: round

P = Ø 5,5 mm

Punch cutting length: l₁

13 mm

Length: l

63 mm

Diameter: d₂

13 mm

Type:

heavy

Execution:

round

Punch:

with ejector pin

= 0550

Order No

= (1)

Order Code character

= (C)

Order No

= (3)

Order No

= (3)

Order No

= (1)

= 27

BALL-LOCK PUNCH, STEPPED, SQUARE, WITH EJECTOR PIN, HEAVY DUTY

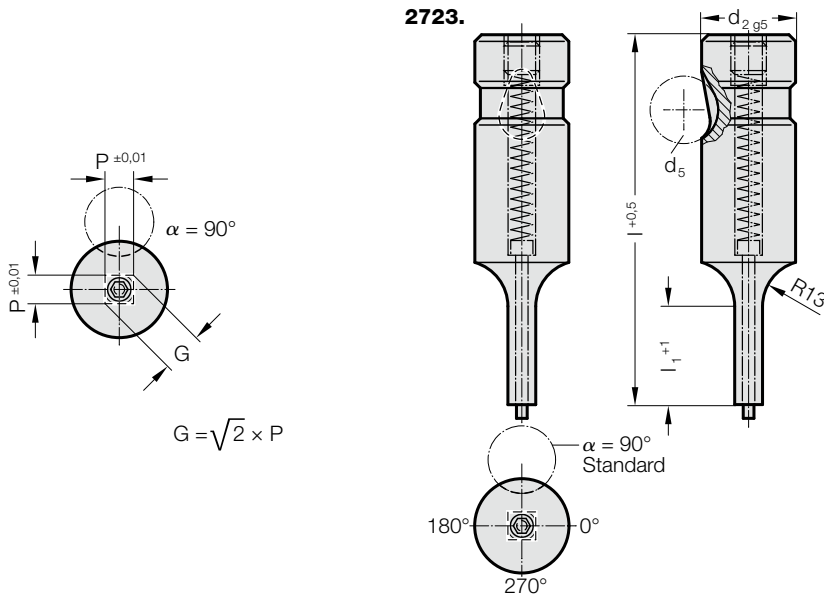

2723. Ball-Lock punch, stepped, square, with ejector pin, heavy duty

d ₂ / Order No	d ₅	P _{min}	G _{max}	l ₁ / Order No	l (Order Code character)	63 (C)	71 (D)	80 (E)	90 (F)	100 (G)	110 (H)	125 (J)
10 / (2)	10	4	9.9	13(1) 19(2)		●	●	●	●	●		
13 / (3)	12	6	12.9	13(1) 19(2)		●	●	●	●	●	●	●
16 / (4)	12	8	15.9	13(1) 19(2) 25(3)		●	●	●	●	●	●	●
20 / (5)	12	10	19.9	13(1) 19(2) 25(3)		●	●	●	●	●	●	●
25 / (6)	12	12	24.9	13(1) 19(2) 25(3)			●	●	●	●	●	●
32 / (7)	12	16	31.9	13(1) 19(2) 25(3)			●	●	●	●	●	●
40 / (9)	12	19	39.9	19(2) 25(3) 30(4)				●	●	●	●	●

*at d₂ = 16/ 20 and l = 63; l_{1 max.} = 19

Ordering Code (example):

2723.2F1.0650.B

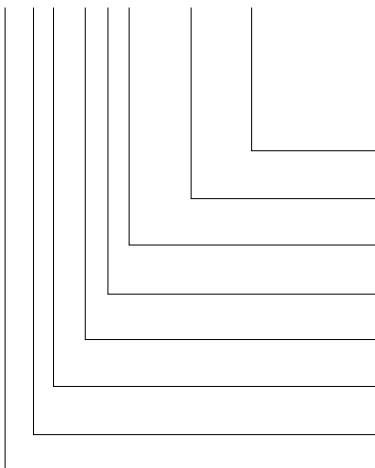

Angle:
90°
Shape: square, Length P
P = 6,5 mm
Punch cutting length: l₁
13 mm
Length: l
90 mm
Diameter: d₂
10 mm
Type:
heavy
Execution:
square
Punch:
with ejector pin

Order Code character
= (B)
Order No
= 0650
Order Code character
= (F)
Order No
= (2)
Order No
= (3)
Order No
= (2)
Order No
= 27

Material:

HSS
Hardness 62 ± 2 HRC

Execution:

Shaft and punch shape fine ground.
Special dimensions on request.

Note:

With kerf ≤ 0.04 mm, FIBRO rounds off sharp edges if the punch and piercing die bush are ordered together. This reduces the fitting time and the risk of an edge break during operation.

BALL-LOCK PUNCH, STEPPED, RECTANGULAR, WITH EJECTOR PIN, HEAVY DUTY

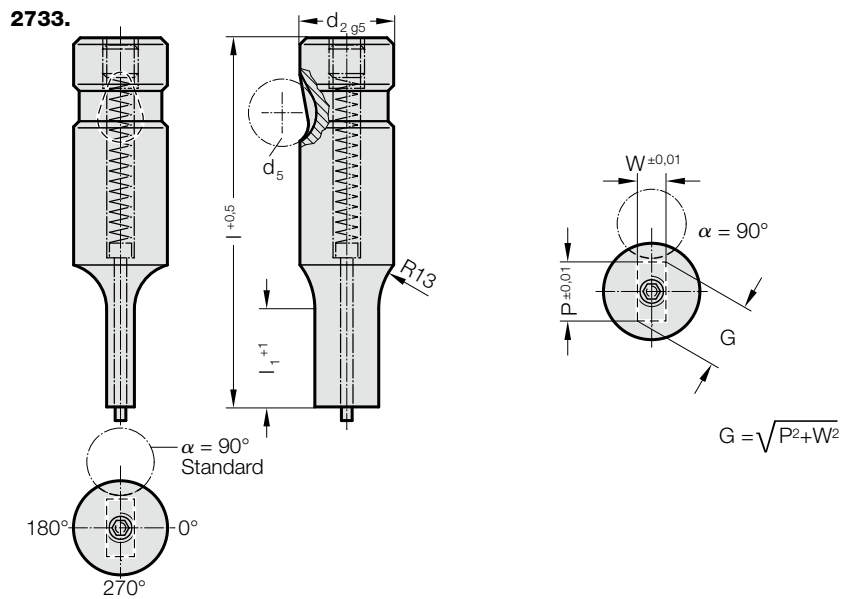

2733. Ball-Lock punch, stepped, rectangular, with ejector pin, heavy duty

d ₂ / Order No	d ₅	W _{min}	G _{max}	l ₁ / Order No	l (Order Code character)	63 (C)	71 (D)	80 (E)	90 (F)	100 (G)	110 (H)	125 (J)
10 / (2)	10	4	9.9	13(1) 19(2)		●	●	●	●	●		
13 / (3)	12	6	12.9	13(1) 19(2)		●	●	●	●	●	●	●
16 / (4)	12	8	15.9	13(1) 19(2) 25(3)		●	●	●	●	●	●	●
20 / (5)	12	10	19.9	13(1) 19(2) 25(3)		●	●	●	●	●	●	●
25 / (6)	12	12	24.9	13(1) 19(2) 25(3)			●	●	●	●	●	●
32 / (7)	12	16	31.9	13(1) 19(2) 25(3)			●	●	●	●	●	●
40 / (9)	12	19	39.9	19(2) 25(3) 30(4)				●	●	●	●	●

*at d₂ = 16/ 20 and l = 63; l_{1 max.} = 19

Material:

HSS

Hardness 62 ± 2 HRC

Execution:

Shaft and punch shape fine ground.
Special dimensions on request.

Note:

With kerf ≤ 0.04 mm, FIBRO rounds off sharp edges if the punch and piercing die bush are ordered together. This reduces the fitting time and the risk of an edge break during operation.

Ordering Code (example):

2733.7F2.1420.1250.B

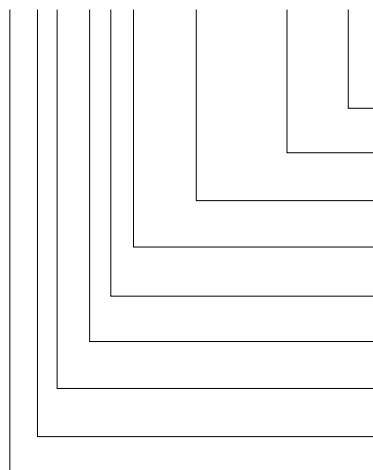

Angle:

90°

Shape: rectangular, Width W

W = 12,50 mm

Shape: rectangular, Length P

P = 14,20 mm

Punch cutting length: l₁

19 mm

Length: l

90 mm

Diameter: d₂

32 mm

Type:

heavy

Execution:

rectangular

Punch:

with ejector pin

Order Code character

= (B)

= 1250

= 1420

Order No

= (2)

Order Code character

= (F)

Order No

= (7)

Order No

= (3)

Order No

= (3)

= 27

BALL-LOCK PUNCH, STEPPED, SLOT, WITH EJECTOR PIN, HEAVY DUTY

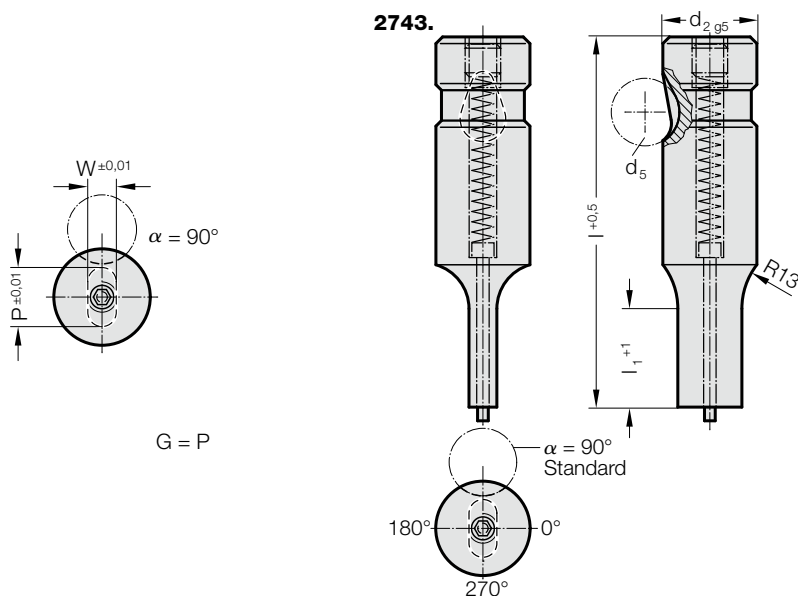

2743. Ball-Lock punch, stepped, slot, with ejector pin, heavy duty

d ₂ / Order No	d ₅	W _{min}	G _{max}	l ₁ / Order No	l (Order Code character)	63	71	80	90	100	110	125
						(C)	(D)	(E)	(F)	(G)	(H)	(J)
10 / (2)	10	4	9.9	13(1) 19(2)		●	●	●	●	●		
13 / (3)	12	6	12.9	13(1) 19(2)		●	●	●	●	●	●	●
16 / (4)	12	8	15.9	13(1) 19(2) 25(3)		●	●	●	●	●	●	●
20 / (5)	12	10	19.9	13(1) 19(2) 25(3)		●	●	●	●	●	●	●
25 / (6)	12	12	24.9	13(1) 19(2) 25(3)			●	●	●	●	●	●
32 / (7)	12	16	31.9	13(1) 19(2) 25(3)			●	●	●	●	●	●
40 / (9)	12	19	39.9	19(2) 25(3) 30(4)				●	●	●	●	●

*at d₂ = 16/ 20 and l = 63; l_{1 max.} = 19

Ordering Code (example):

2743.2F1.0650.0450.B

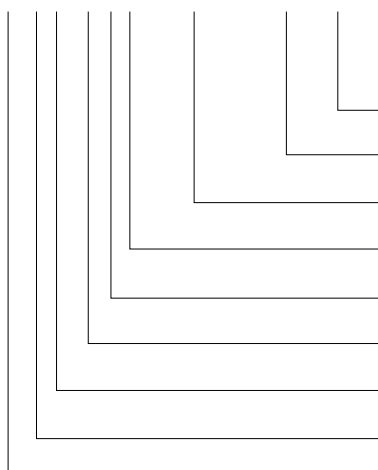

Angle:
90°
Shape: slot, Width W
W = 4,50 mm
Shape: slot, Length P
P = 6,50 mm
Punch cutting length: l₁
13 mm
Length: l
90 mm
Diameter: d₂
10 mm
Type:
heavy
Execution:
slot
Punch:
with ejector pin

Order Code character
= (B)
= 0450
= 0650
Order No
= (1)
Order Code character
= (F)
Order No
= (2)
Order No
= (3)
Order No
= (4)
= 27

Material:

HSS
Hardness 62 ± 2 HRC

Execution:

Shaft and punch shape fine ground.
Special dimensions on request.

BALL-LOCK PUNCH, STEPPED, RECTANGLE WITH RADIUSSED CORNERS, WITH EJECTOR PIN, HEAVY DUTY

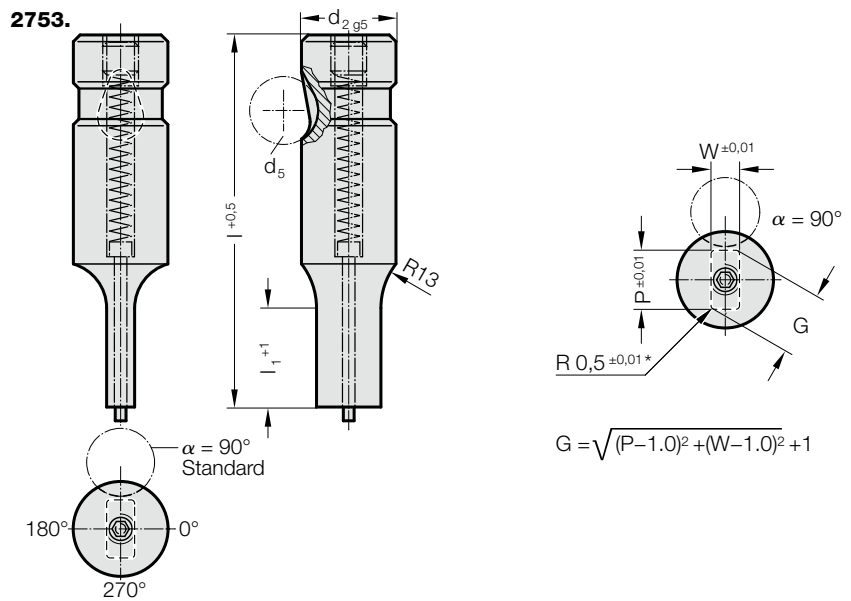

2753. Ball-Lock punch, stepped, rectangle with radiussed corners, with ejector pin, heavy duty

d ₂ / Order No	d ₅	W _{min}	G _{max}	l ₁ / Order No	l (Order Code character)	63 (C)	71 (D)	80 (E)	90 (F)	100 (G)	110 (H)	125 (J)
10 / (2)	10	4	9.9	13(1) 19(2)		●	●	●	●	●		
13 / (3)	12	6	12.9	13(1) 19(2)		●	●	●	●	●	●	●
16 / (4)	12	8	15.9	13(1) 19(2) 25(3)		●	●	●	●	●	●	●
20 / (5)	12	10	19.9	13(1) 19(2) 25(3)		●	●	●	●	●	●	●
25 / (6)	12	12	24.9	13(1) 19(2) 25(3)			●	●	●	●	●	●
32 / (7)	12	16	31.9	13(1) 19(2) 25(3)			●	●	●	●	●	●
40 / (9)	12	19	39.9	19(2) 25(3) 30(4)				●	●	●	●	●

*at d₂ = 16/ 20 and l = 63; l_{1 max.} = 19

Material:

HSS
Hardness 62 ± 2 HRC

Execution:

Shaft and punch shape fine ground.
Special dimensions on request.
* For other radius options, see standardised special shapes.

Ordering Code (example):

2753.3F1.1215.0915.B

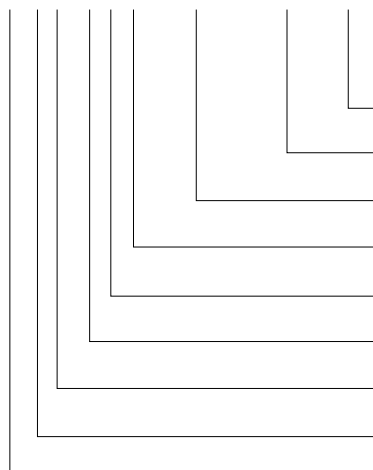

Angle: 90°
Shape: rectangle with radiussed corners, Width W = 9,15 mm
Shape: rectangle with radiussed corners, Length P = 12,15 mm
Punch cutting length: l₁ = 13 mm
Length: l = 90 mm
Diameter: d₂ = 13 mm
Type: heavy
Execution: rectangle with radiussed corners
Punch: with ejector pin

Order Code character = (B)
Order Code character = (F)
Order No = (1)
Order Code character = (F)
Order No = (3)
Order No = (3)
Order No = (5)
Order No = (3)
Order No = (5)

BALL-LOCK PUNCH, PUNCH LARGER THAN SHAFT, BLANK, HEAVY DUTY

2205.

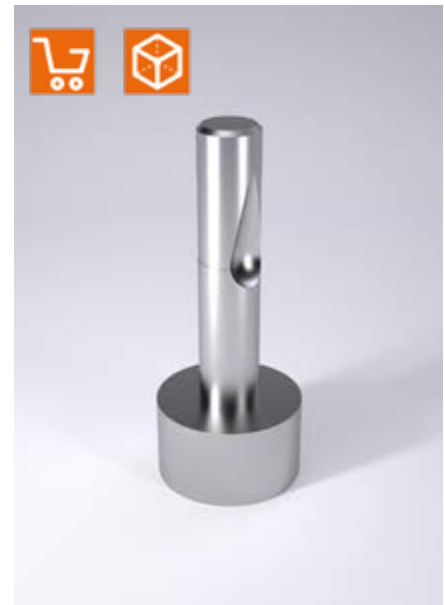
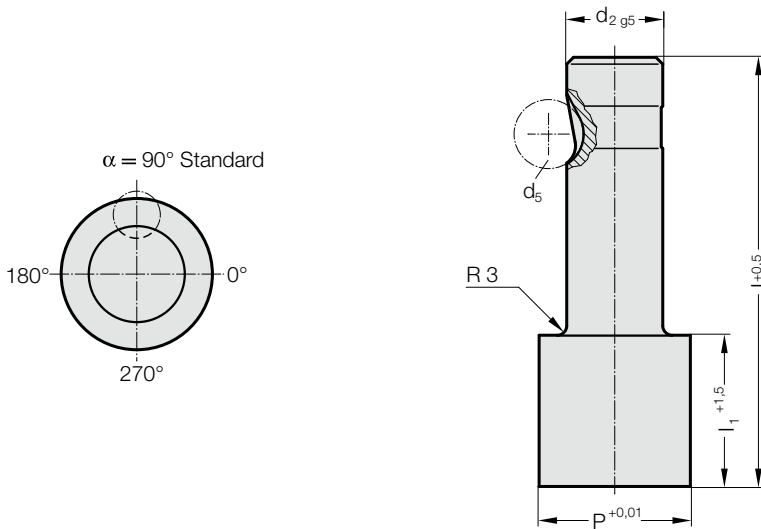

2205. Ball-Lock punch, punch larger than shaft, blank, heavy duty

d ₂ / Order No	d ₅	P	l ₁ / Order No	l (Order Code character)	80 (E)	90 (F)	100 (G)
13 / (3)	12	32	19(2) 30(4)		●	●	●
16 / (4)	12	38	19(2) 30(4)		●	●	●
20 / (5)	12	40	19(2) 30(4)		●	●	●
25 / (6)	12	44	19(2) 30(4)		●	●	●
32 / (7)	12	50	19(2) 30(4)		●	●	●
40 / (9)	12	56	19(2) 30(4)		●	●	●

Ordering Code (example):

2205.7G4.5000

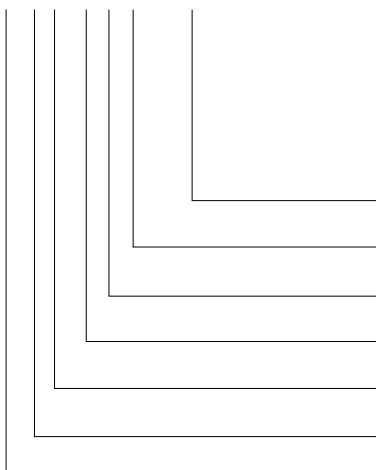

Shape: round

P = Ø 50 mm

Punch cutting length: l₁

30 mm

Length: l

100 mm

Diameter: d₂

32 mm

Type:

punch larger, heavy

Execution:

blank

Punch:

without ejector pin

= 5000

Order No

= (4)

Order Code character

= (G)

Order No

= (7)

Order No

= (5)

Order No

= (0)

= 22

Material:

HSS

Hardness 62 ± 2 HRC

Execution:

Shaft and punch diameter fine ground.

Special dimensions on request.

BALL-LOCK PUNCH, PUNCH LARGER THAN SHAFT, ROUND, HEAVY DUTY



2215.

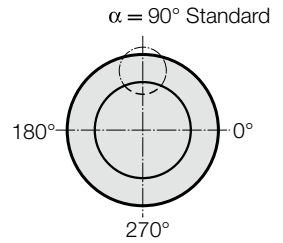
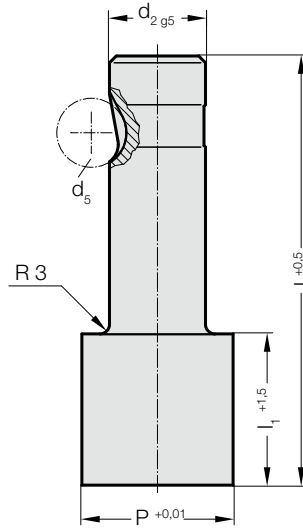

2215. Ball-Lock punch, punch larger than shaft, round, heavy duty

d ₂ / Order No	d ₅	P	l ₁ / Order No	l (Order Code character)	80 (E)	90 (F)	100 (G)
13 / (3)	12	13,1 - 32	19(2) 30(4)		●	●	●
16 / (4)	12	16,1 - 38	19(2) 30(4)		●	●	●
20 / (5)	12	20,1 - 40	19(2) 30(4)		●	●	●
25 / (6)	12	25,1 - 44	19(2) 30(4)		●	●	●
32 / (7)	12	32,1 - 50	19(2) 30(4)		●	●	●
40 / (9)	12	40,1 - 56	19(2) 30(4)		●	●	●

Material:

HSS
Hardness 62 ± 2 HRC

Execution:

Shaft and punch diameter fine ground.
Special dimensions on request.

Ordering Code (example):

2215.7G2.3210

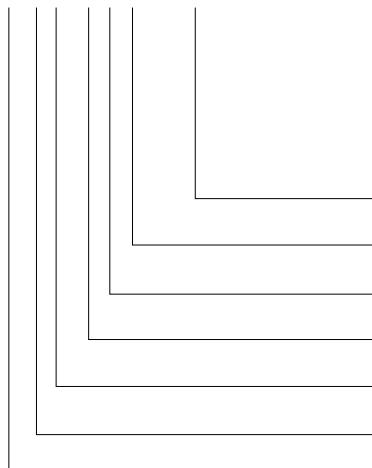

Shape: round

P = ∅ 32,1 mm

Punch cutting length: l₁

19 mm

Length: l

100 mm

Diameter: d₂

32 mm

Type:

punch larger, heavy

Execution:

round

Punch:

without ejector pin

= 3210

Order No

= (2)

Order Code character

= (G)

Order No

= (7)

Order No

= (5)

Order No

= (1)

= 22

BALL-LOCK PUNCH, PUNCH LARGER THAN SHAFT, SQUARE, HEAVY DUTY

2225.

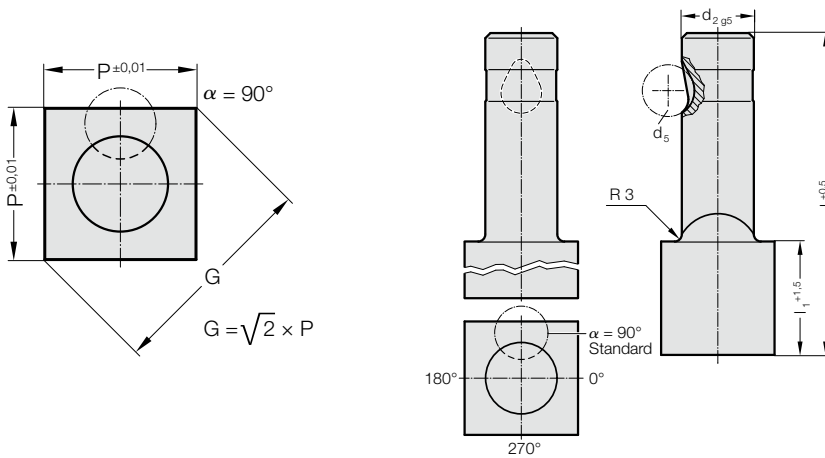

2225. Ball-Lock punch, punch larger than shaft, square, heavy duty

d ₂ / Order No	d ₅	P _{min}	G _{max}	l ₁ / Order No	l (Order Code character)	80	90	100
						(E)	(F)	(G)
13 / (3)	12	9.19	32	19(2) 30(4)		●	●	●
16 / (4)	12	11.31	38	19(2) 30(4)		●	●	●
20 / (5)	12	14.14	40	19(2) 30(4)		●	●	●
25 / (6)	12	17.68	44	19(2) 30(4)		●	●	●
32 / (7)	12	22.63	50	19(2) 30(4)		●	●	●
40 / (9)	12	28.28	56	19(2) 30(4)		●	●	●

Ordering Code (example):

2225.4F4.1150.B

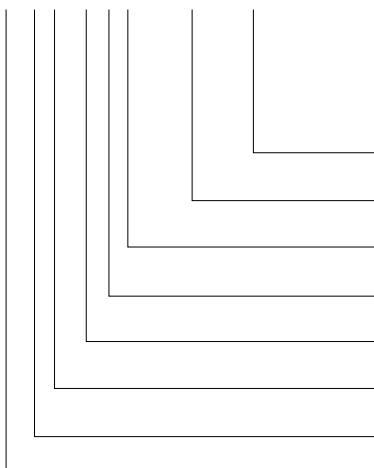

Angle:
90°
Shape: square, Length P
P = 11,5 mm
Punch cutting length: l₁
30 mm
Length: l
90 mm
Diameter: d₂
16 mm
Type:
punch larger, heavy
Execution:
square
Punch:
without ejector pin

Order Code character
= (B)
Order No
= 1150
Order Code character
= (F)
Order No
= (4)
Order No
= (5)
Order No
= (2)

Material:

HSS
Hardness 62 ± 2 HRC

Execution:

Shaft and punch shape fine ground.
Special dimensions on request.

Note:

With kerf ≤ 0.04 mm, FIBRO rounds off sharp edges if the punch and piercing die bush are ordered together. This reduces the fitting time and the risk of an edge break during operation.

BALL-LOCK PUNCH, PUNCH LARGER THAN SHAFT, RECTANGULAR, HEAVY DUTY



2235.

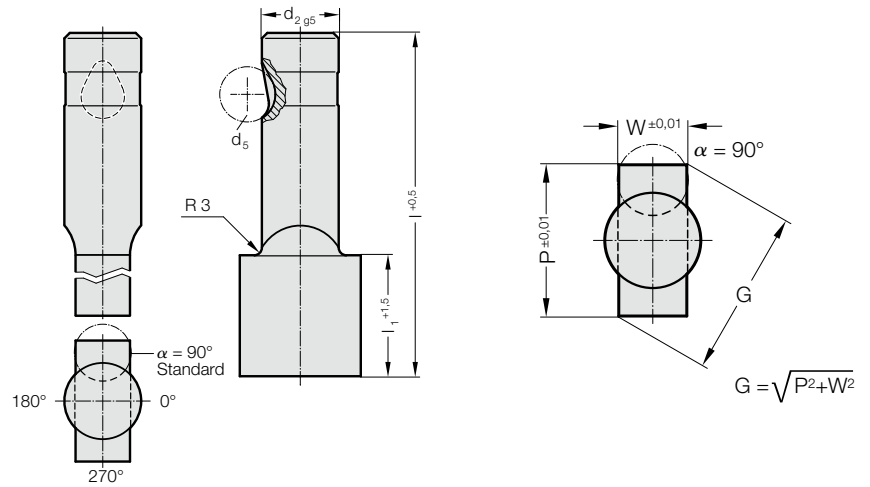

2235. Ball-Lock punch, punch larger than shaft, rectangular, heavy duty

d ₂ / Order No	d ₅	W _{min}	G _{max}	l ₁ / Order No	l (Order Code character)	80 (E)	90 (F)	100 (G)
13 / (3)	12	5	32	19(2) 30(4)		●	●	●
16 / (4)	12	6.5	38	19(2) 30(4)		●	●	●
20 / (5)	12	8	40	19(2) 30(4)		●	●	●
25 / (6)	12	10	44	19(2) 30(4)		●	●	●
32 / (7)	12	11.5	50	19(2) 30(4)		●	●	●
40 / (9)	12	14	56	19(2) 30(4)		●	●	●

Material:

HSS
Hardness 62 ± 2 HRC

Execution:

Shaft and punch shape fine ground.
Special dimensions on request.

Note:

With kerf ≤ 0.04 mm, FIBRO rounds off sharp edges if the punch and piercing die bush are ordered together. This reduces the fitting time and the risk of an edge break during operation.

Ordering Code (example):

2235.4F4.1420.1150.B

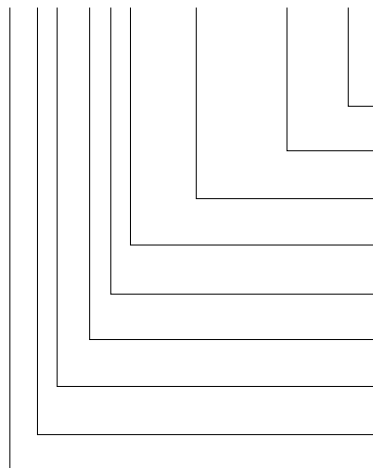

Angle:

90°

Shape: rectangular, Width W

W = 11,5 mm

Shape: rectangular, Length P

P = 14,2 mm

Punch cutting length: l₁

30 mm

Length: l

90 mm

Diameter: d₂

16 mm

Type:

punch larger, heavy

Execution:

rectangular

Punch:

without ejector pin

Order Code character

= (B)

= 1150

= 1420

Order No

= (4)

Order Code character

= (F)

Order No

= (4)

Order No

= (5)

Order No

= (3)

= 22

BALL-LOCK PUNCH, PUNCH LARGER THAN SHAFT, SLOT, HEAVY DUTY

2245.

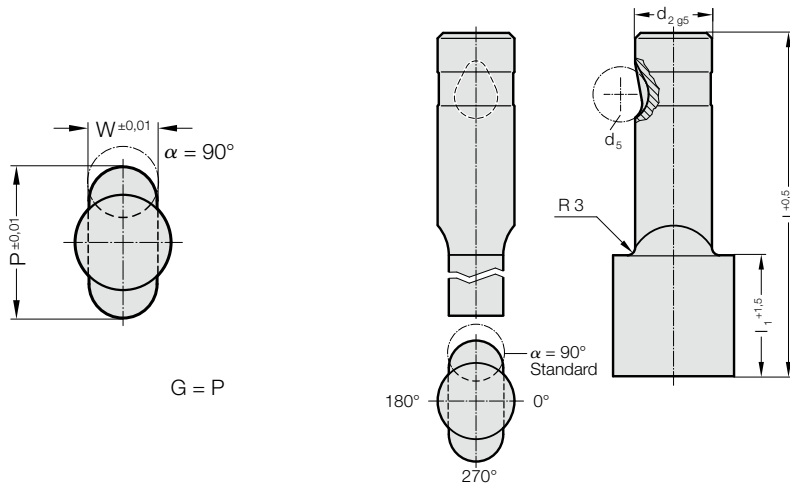

2245. Ball-Lock punch, punch larger than shaft, slot, heavy duty

d ₂ / Order No	d ₅	W _{min}	G _{max}	l ₁ / Order No	l (Order Code character)	80	90	100
						(E)	(F)	(G)
13 / (3)	12	5	32	19(2) 30(4)		●	●	●
16 / (4)	12	6.5	38	19(2) 30(4)		●	●	●
20 / (5)	12	8	40	19(2) 30(4)		●	●	●
25 / (6)	12	10	44	19(2) 30(4)		●	●	●
32 / (7)	12	11.5	50	19(2) 30(4)		●	●	●
40 / (9)	12	14	56	19(2) 30(4)		●	●	●

Ordering Code (example):

2245.7F2.3720.1150.B

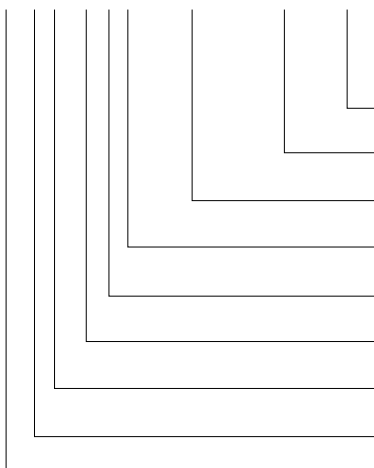

Angle:
90°
Shape: slot, Width W
W = 11,5 mm
Shape: slot, Length P
P = 37,2 mm
Punch cutting length: l₁
19 mm
Length: l
90 mm
Diameter: d₂
32 mm
Type:
punch larger, heavy
Execution:
slot
Punch:
without ejector pin

Order Code character
= (B)
= 1150
= 3720
Order No
= (2)
Order Code character
= (F)
Order No
= (7)
Order No
= (5)
Order No
= (4)
= 22

Material:

HSS
Hardness 62 ± 2 HRC

Execution:

Shaft and punch shape fine ground.
Special dimensions on request.

BALL-LOCK PUNCH, PUNCH LARGER THAN SHAFT, RECTANGLE WITH RADIUSSED CORNERS, HEAVY DUTY



2255.

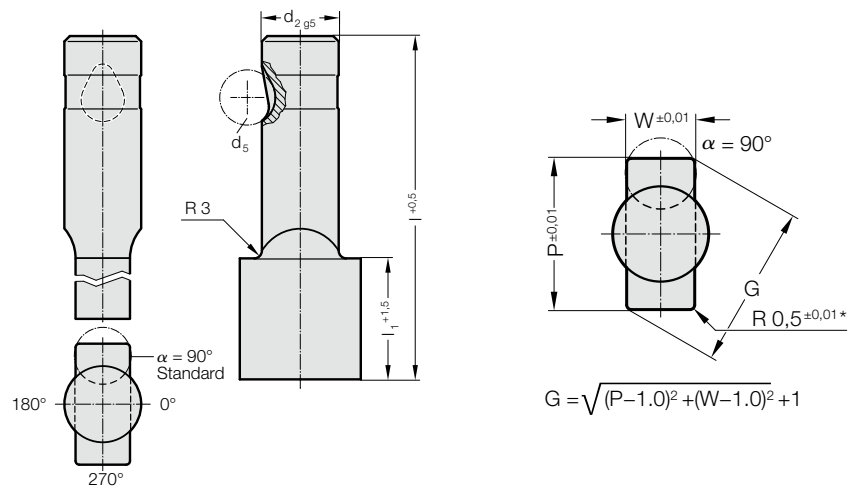

2255. Ball-Lock punch, punch larger than shaft, rectangle with radiussed corners, heavy duty

d ₂ / Order No	d ₅	W _{min}	G _{max}	l ₁ / Order No	l (Order Code character)	80 (E)	90 (F)	100 (G)
13 / (3)	12	5	32	19(2) 30(4)		●	●	●
16 / (4)	12	6.5	38	19(2) 30(4)		●	●	●
20 / (5)	12	8	40	19(2) 30(4)		●	●	●
25 / (6)	12	10	44	19(2) 30(4)		●	●	●
32 / (7)	12	11.5	50	19(2) 30(4)		●	●	●
40 / (9)	12	14	56	19(2) 30(4)		●	●	●

Material:

HSS
Hardness 62 ± 2 HRC

Execution:

Shaft and punch shape fine ground.
Special dimensions on request.
* For other radius options, see standardised special shapes.

Ordering Code (example):

2255.4F2.1420.1150.B

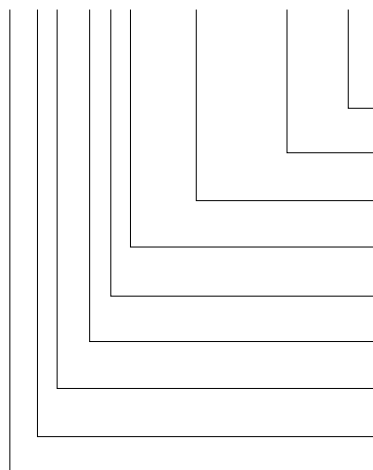

Angle: 90°
Shape: rectangle with radiussed corners, Width W = 11,5 mm
Shape: rectangle with radiussed corners, Length P = 14,2 mm
Punch cutting length: l₁ = 19 mm
Length: l = 90 mm
Diameter: d₂ = 16 mm
Type: punch larger, heavy
Execution: rectangle with radiussed corners
Punch: without ejector pin

Order Code character = (B)
Order Code character = (F)
Order No = (2)
Order Code character = (F)
Order No = (4)
Order No = (5)
Order No = (5)

BALL-LOCK PUNCH, PUNCH LARGER THAN SHAFT, BLANK, WITH EJECTOR PIN, HEAVY DUTY

2705.

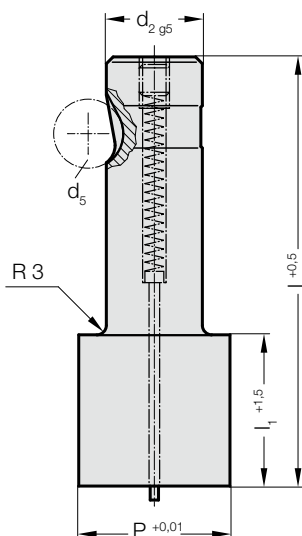
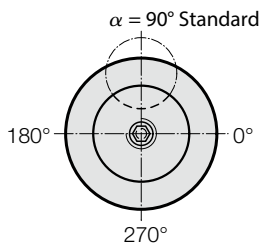

2705. Ball-Lock punch, punch larger than shaft, blank, with ejector pin, heavy duty

d ₂ / Order No	P	l ₁ / Order No	l (Order Code character)	80 (E)	90 (F)	100 (G)
13 / (3)	32	19 (2) 30 (4)		●	●	●
16 / (4)	38	19 (2) 30 (4)		●	●	●
20 / (5)	40	19 (2) 30 (4)		●	●	●
25 / (6)	44	19 (2) 30 (4)		●	●	●
32 / (7)	50	19 (2) 30 (4)		●	●	●
40 / (9)	56	19 (2) 30 (4)		●	●	●

Ordering Code (example):

2705.7G4.5000

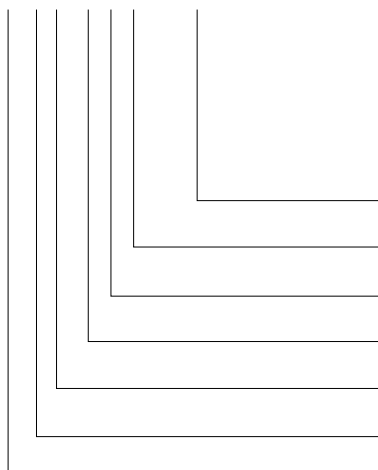

Shape: round
 P = Ø 50 mm
Punch cutting length: l₁
 30 mm
Length: l
 100 mm
Diameter: d₂
 32 mm
Type:
 punch larger, heavy
Execution:
 blank
Punch:
 with ejector pin

= 5000
Order No
 = (4)
Order Code character
 = (G)
Order No
 = (7)
Order No
 = (5)
Order No
 = (0)

Material:

HSS
 Hardness 62 ± 2 HRC

Execution:

Shaft and punch diameter fine ground.
 Special dimensions on request.

BALL-LOCK PUNCH, PUNCH LARGER THAN SHAFT, ROUND, WITH EJECTOR PIN, HEAVY DUTY



2715.

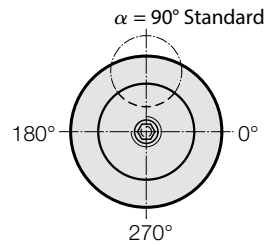
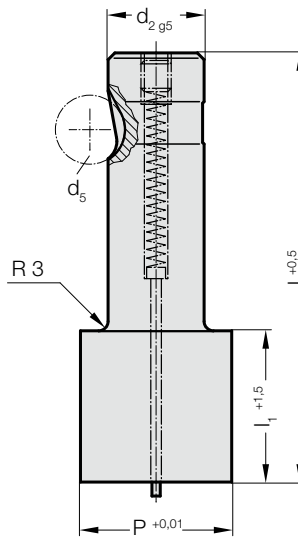

2715. Ball-Lock punch, punch larger than shaft, round, with ejector pin, heavy duty

d ₂ / Order No	d ₅	P	l ₁ / Order No	l (Order Code character)	80 (E)	90 (F)	100 (G)
13 / (3)	12	13,1 - 32	19 (2) 30 (4)		●	●	●
16 / (4)	12	16,1 - 38	19 (2) 30 (4)		●	●	●
20 / (5)	12	20,1 - 40	19 (2) 30 (4)		●	●	●
25 / (6)	12	25,1 - 44	19 (2) 30 (4)		●	●	●
32 / (7)	12	32,1 - 50	19 (2) 30 (4)		●	●	●
40 / (9)	12	40,1 - 56	19 (2) 30 (4)		●	●	●

Material:

HSS
Hardness 62 ± 2 HRC

Execution:

Shaft and punch diameter fine ground.
Special dimensions on request.

Ordering Code (example):

2715.7G2.3210

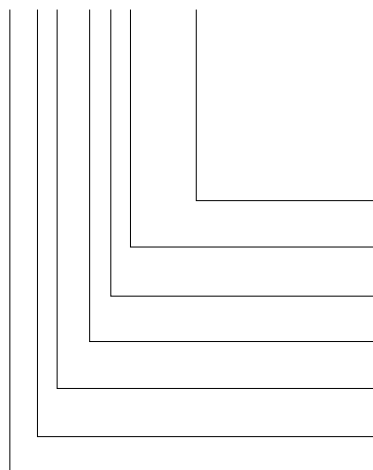

Shape: round

P = Ø 32,1 mm

Punch cutting length: l₁
19 mm

Length: l

100 mm

Diameter: d₂

32 mm

Type:

punch larger, heavy

Execution:

round

Punch:

with ejector pin

= 3210

Order No

= (2)

Order Code character

= (G)

Order No

= (7)

Order No

= (5)

Order No

= (1)

= 27

BALL-LOCK PUNCH, PUNCH LARGER THAN SHAFT, SQUARE, WITH EJECTOR PIN, HEAVY DUTY

2725.

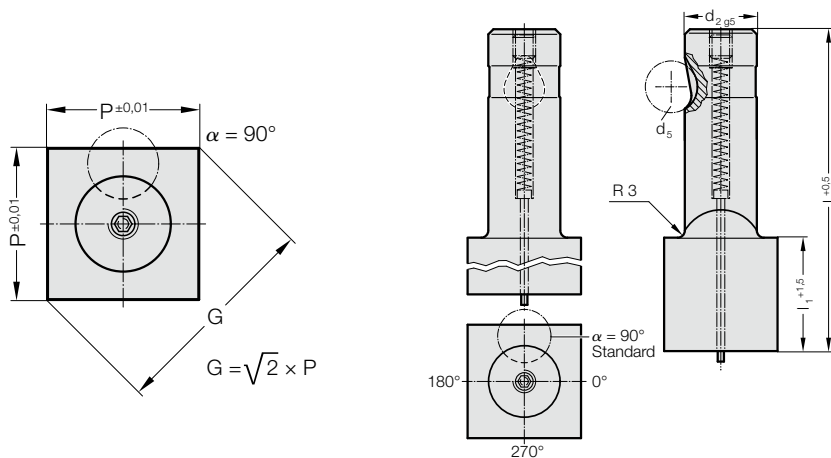

2725. Ball-Lock punch, punch larger than shaft, square, with ejector pin, heavy duty

d ₂ / Order No	d ₅	P _{min}	G _{max}	l ₁ / Order No	l (Order Code character)	80 (E)	90 (F)	100 (G)
13 / (3)	12	9.19	32	19 (2) 30 (4)		●	●	●
16 / (4)	12	11.31	38	19 (2) 30 (4)		●	●	●
20 / (5)	12	14.14	40	19 (2) 30 (4)		●	●	●
25 / (6)	12	17.68	44	19 (2) 30 (4)		●	●	●
32 / (7)	12	22.63	50	19 (2) 30 (4)		●	●	●
40 / (9)	12	28.28	56	19 (2) 30 (4)		●	●	●

Ordering Code (example):

2725.4F4.2450.B

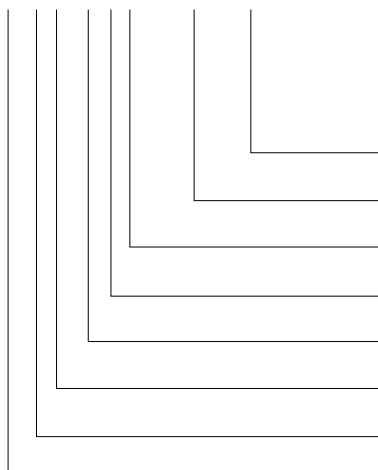

Angle:
90°
Shape: square, Length P
P = 24,5 mm
Punch cutting length: l₁
30 mm
Length: l
90 mm
Diameter: d₂
16 mm
Type:
punch larger, heavy
Execution:
square
Punch:
with ejector pin

Order Code character
= (B)
Order No
= 2450
Order Code character
= (F)
Order No
= (4)
Order No
= (5)
Order No
= (2)
Order No
= 27

Material:

HSS
Hardness 62 ± 2 HRC

Execution:

Shaft and punch shape fine ground.
Special dimensions on request.

Note:

With kerf ≤ 0.04 mm, FIBRO rounds off sharp edges if the punch and piercing die bush are ordered together. This reduces the fitting time and the risk of an edge break during operation.

BALL-LOCK PUNCH, PUNCH LARGER THAN SHAFT, RECTANGULAR, WITH EJECTOR PIN, HEAVY DUTY



2735.

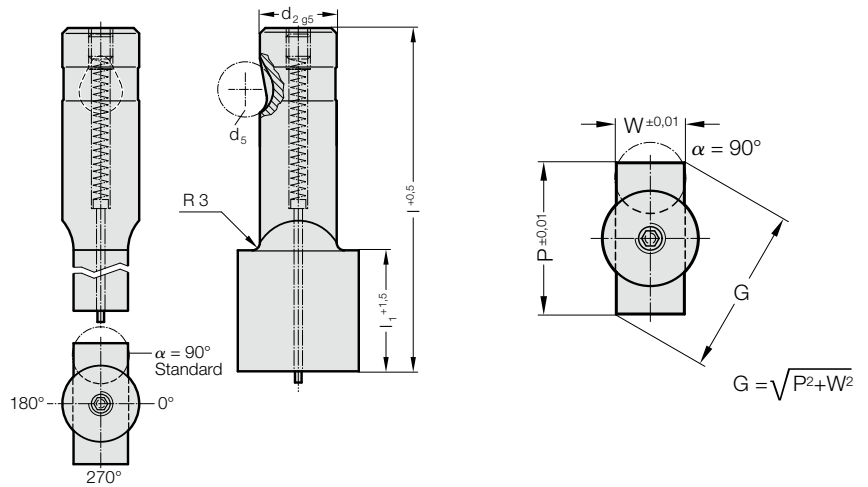

2735. Ball-Lock punch, punch larger than shaft, rectangular, with ejector pin, heavy duty

d ₂ / Order No	d ₅	W _{min}	G _{max}	l ₁ / Order No	l (Order Code character)	80 (E)	90 (F)	100 (G)
13 / (3)	12	5	32	19 (2) 30 (4)		●	●	●
16 / (4)	12	6.5	38	19 (2) 30 (4)		●	●	●
20 / (5)	12	8	40	19 (2) 30 (4)		●	●	●
25 / (6)	12	10	44	19 (2) 30 (4)		●	●	●
32 / (7)	12	11.5	50	19 (2) 30 (4)		●	●	●
40 / (9)	12	14	56	19 (2) 30 (4)		●	●	●

Material:

HSS
Hardness 62 ± 2 HRC

Execution:

Shaft and punch shape fine ground.
Special dimensions on request.

Note:

With kerf ≤ 0.04 mm, FIBRO rounds off sharp edges if the punch and piercing die bush are ordered together. This reduces the fitting time and the risk of an edge break during operation.

Ordering Code (example):

2735.4F4.1420.1150.B

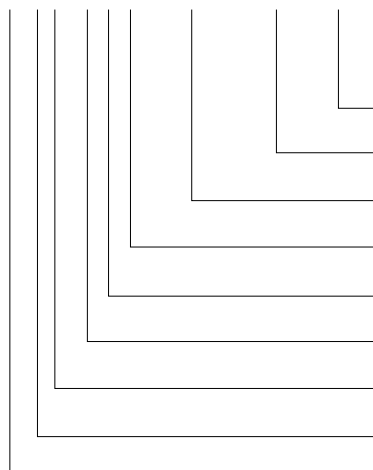

Angle:

90°

Shape: rectangular, Width W

W = 11,5 mm

Shape: rectangular, Length P

P = 14,2 mm

Punch cutting length: l₁

30 mm

Length: l

90 mm

Diameter: d₂

16 mm

Type:

punch larger, heavy

Execution:

rectangular

Punch:

with ejector pin

Order Code character

= (B)

= 1150

= 1420

Order No

= (4)

Order Code character

= (F)

Order No

= (4)

Order No

= (5)

Order No

= (3)

= 27

BALL-LOCK PUNCH, PUNCH LARGER THAN SHAFT, SLOT, WITH EJECTOR PIN, HEAVY DUTY

2745.

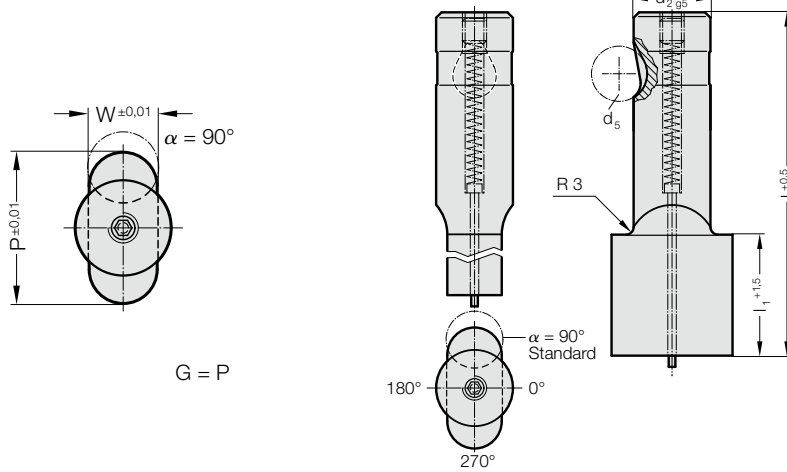

2745. Ball-Lock punch, punch larger than shaft, slot, with ejector pin, heavy duty

d ₂ / Order No	d ₅	W _{min}	G _{max}	l ₁ / Order No	l (Order Code character)	80	90	100
						(E)	(F)	(G)
13 / (3)	12	5	32	19 (2) 30 (4)		●	●	●
16 / (4)	12	6.5	38	19 (2) 30 (4)		●	●	●
20 / (5)	12	8	40	19 (2) 30 (4)		●	●	●
25 / (6)	12	10	44	19 (2) 30 (4)		●	●	●
32 / (7)	12	11.5	50	19 (2) 30 (4)		●	●	●
40 / (9)	12	14	56	19 (2) 30 (4)		●	●	●

Ordering Code (example):

2745.7F2.3720.1150.B

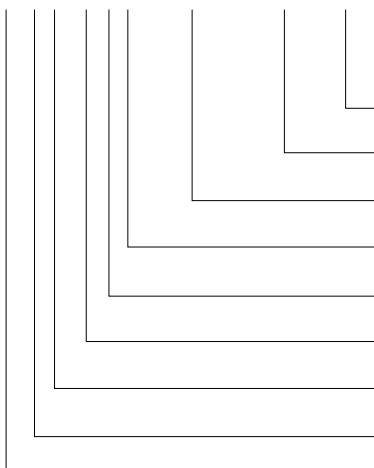

Angle:
90°
Shape: slot, Width W
W = 11,5 mm
Shape: slot, Length P
P = 37,2 mm
Punch cutting length: l₁
19 mm
Length: l
90 mm
Diameter: d₂
32 mm
Type:
punch larger, heavy
Execution:
slot
Punch:
with ejector pin

Order Code character
= (B)
= 1150
= 3720
Order No
= (2)
Order Code character
= (F)
Order No
= (7)
Order No
= (5)
Order No
= (4)
= 27

Material:

HSS
Hardness 62 ± 2 HRC

Execution:

Shaft and punch shape fine ground.
Special dimensions on request.

BALL-LOCK PUNCH, PUNCH LARGER THAN SHAFT, RECTANGLE WITH RADIUSSED CORNERS, WITH EJECTOR PIN, HEAVY DUTY



2755.

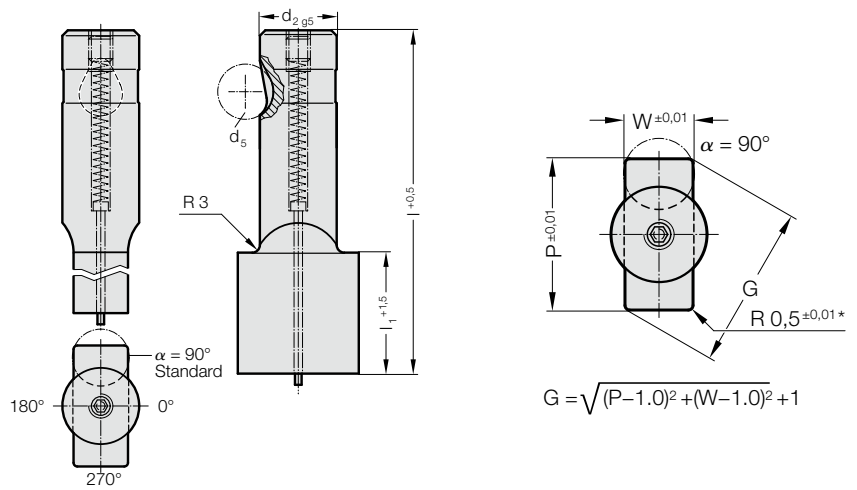

2755. Ball-Lock punch, punch larger than shaft, rectangle with radiused corners, with ejector pin, heavy duty

d ₂ / Order No	d ₅	W _{min}	G _{max}	l ₁ / Order No	l (Order Code character)	80 (E)	90 (F)	100 (G)
13 / (3)	12	5	32	19 (2) 30 (4)		●	●	●
16 / (4)	12	6.5	38	19 (2) 30 (4)		●	●	●
20 / (5)	12	8	40	19 (2) 30 (4)		●	●	●
25 / (6)	12	10	44	19 (2) 30 (4)		●	●	●
32 / (7)	12	11.5	50	19 (2) 30 (4)		●	●	●
40 / (9)	12	14	56	19 (2) 30 (4)		●	●	●

Material:

HSS
Hardness 62 ± 2 HRC

Execution:

Shaft and punch shape fine ground.
Special dimensions on request.
* For other radius options, see standardised special shapes.

Ordering Code (example):

2755.3F2.1215.1150.B

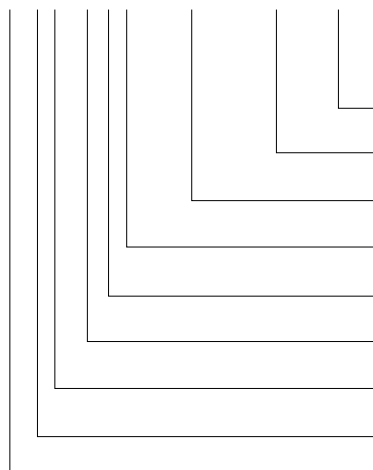

Angle: 90°
Shape: rectangle with radiused corners, Width W = 11,5 mm
Shape: rectangle with radiused corners, Length P = 12,15 mm
Punch cutting length: l₁ = 19 mm
Length: l = 90 mm
Diameter: d₂ = 13 mm
Type: punch larger, heavy
Execution: rectangle with radiused corners
Punch: with ejector pin

Order Code character = (B)
Order Code character = (F)
Order No = 1215
Order No = (2)
Order Code character = (F)
Order No = 1150
Order No = (3)
Order No = (5)
Order No = (5)
Order No = (5)

BALL-LOCK PILOT PIN, WITH TAPERED TIP, HEAVY DUTY

2263.

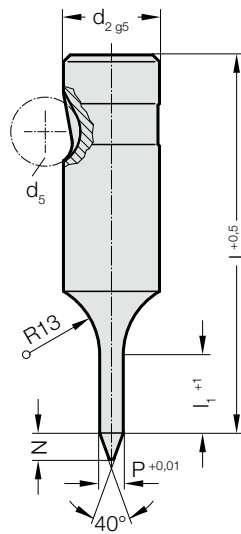

2263. Ball-Lock pilot pin, with tapered tip, heavy duty

d ₂ / Order No	d ₅	P	l ₁ / Order No	N	I (Order Code character)	71 (D)	80 (E)	90 (F)	100 (G)	110 (H)	125 (J)	140 (K)	150 (L)
10 / (2)	10	5,9 - 9,9	19 (2)	8		●	●	●	●	●			
13 / (3)	12	9,9 - 12,9	19 (2)	10		●	●	●	●	●	●		
16 / (4)	12	12,9 - 15,9	25 (3)	15		●	●	●	●	●	●	●	●
20 / (5)	12	15,9 - 19,9	25 (3)	20		●	●	●	●	●	●	●	●
25 / (6)	12	19,9 - 24,9	25 (3)	25			●	●	●	●	●	●	●
32 / (7)	12	24,9 - 31,9	25 (3)	30			●	●	●	●	●	●	●
40 / (9)	12	31,9 - 39,9	30 (4)	40			●	●	●	●	●	●	●

Ordering Code (example):

2263.4G3.1410

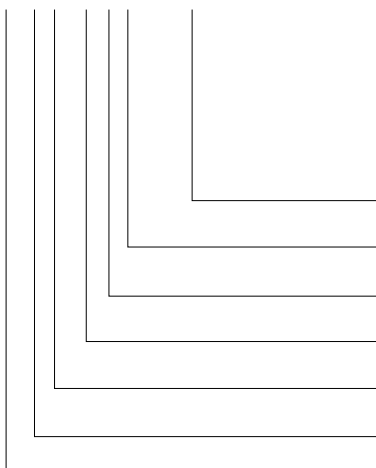

Shape: round

P = Ø 14,1 mm

Punch cutting length: l₁

25 mm

Length: l

100 mm

Diameter: d₂

16 mm

Type:

heavy

Execution:

Pilot pin with tapered tip

Punch:

without ejector pin

= 1410

Order No

= (3)

Order Code character

= (G)

Order No

= (4)

Order No

= (3)

Order No

= (6)

= 22

Material:

HSS

Hardness 62 ± 2 HRC

Execution:

Shaft and pilot pin fine ground.

Special dimensions on request.

BALL-LOCK PILOT PIN, WITH PARABOLIC TIP, HEAVY DUTY



2273.

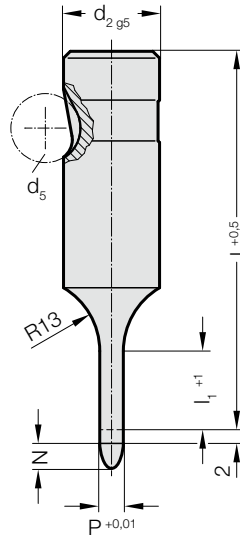

2273. Ball-Lock pilot pin, with parabolic tip, heavy duty

d ₂ / Order No	d ₅	P	l ₁ / Order No	l (Order Code character)	63 (C)	71 (D)	80 (E)	90 (F)	100 (G)	110 (H)	125 (J)
10 / (2)	10	5,9 - 9,9	19 (2)		●	●	●	●	●		
13 / (3)	12	9,9 - 12,9	19 (2)		●	●	●	●	●	●	●
16 / (4)	12	12,9 - 15,9	25 (3)		●	●	●	●	●	●	●
20 / (5)	12	15,9 - 19,9	25 (3)		●	●	●	●	●	●	●
25 / (6)	12	19,9 - 24,9	25 (3)		●	●	●	●	●	●	●
32 / (7)	12	24,9 - 31,9	25 (3)			●	●	●	●	●	●
40 / (9)	12	31,9 - 39,9	30 (4)				●	●	●	●	●

Material:

HSS
Hardness 62 ± 2 HRC

Execution:

Shaft and pilot pin fine ground.
Special dimensions on request.

Note:

The 2 mm length provides full guidance before the blanking punch contacts the sheet metal.

Length of parabolic tip N:

= 8 mm where P ≤ 10 mm
= 12 mm where P 10,1 mm - 15 mm
= 15 mm where P > 15 mm

Ordering Code (example):

2273.4G3.1410

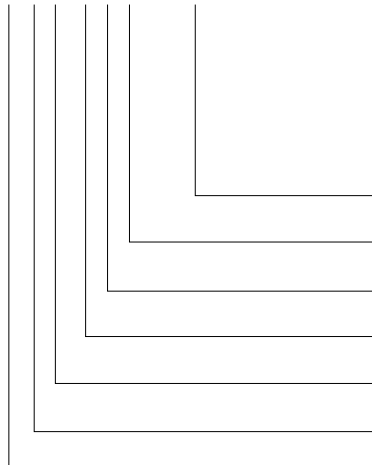

Shape: round

P = Ø 14,1 mm

Punch cutting length: l₁

25 mm

Length: l

100 mm

Diameter: d₂

16 mm

Type:

heavy

Execution:

Pilot pin with parabolic tip

Punch:

without ejector pin

= 1410

Order No

= (3)

Order Code character

= (G)

Order No

= (4)

Order No

= (3)

Order No

= (7)

= 22

PUNCHES ISO 8020

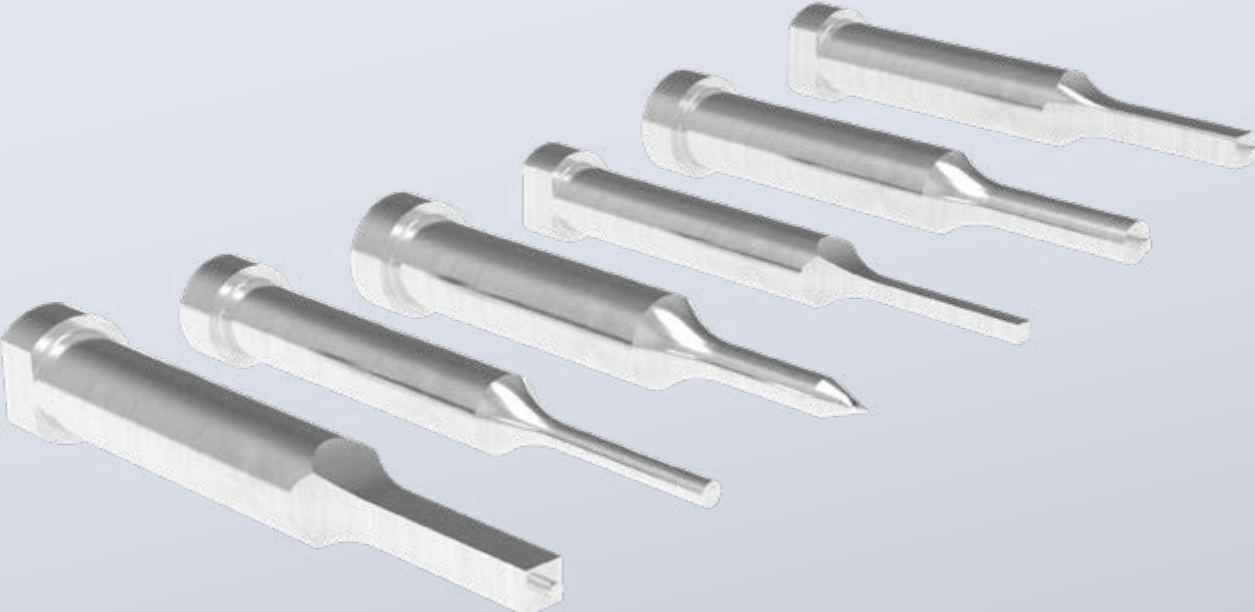

PUNCH ISO 8020 - EXAMPLE ORDERS

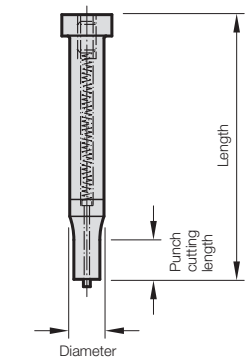

Punch:
22 without ejector pin
27 with ejector pin

Note: See table for standard dimensions
Special dimensions to order

2 2 4 1 . 7 G 4 . 0 6 5 0 . 0 4 5 0 . A

Execution:	Order No
○ blank	= 0
⊙ round	= 1
□ square	= 2
▭ rectangular	= 3
⊔ slot	= 4
▭ rectangle with radiused corners	= 5
▽ Pilot pin with tapered tip	= 6
⊖ Pilot pin parabolic tip	= 7
special shapes	= 9

Type:	Order No
ISO	= 1

Punch cutting length: l_1	Order No
8	= 1
10	= 2
13	= 3
19	= 4
25	= 5
30	= 6
special	= X

Format: Slot
length P = 6.5 mm

Form: Slot
width = 4.5 mm

Length: l	Order Code character
-----------	----------------------

50	= A
56	= B
63	= C
71	= D
80	= E
90	= F
100	= G
110	= H
120	= J
125	= K
140	= L
150	= M
200	= N
special	= X

Angle:	Order Code character
0°	= A
90°	= B
180°	= C
270°	= D
special	= X

Diameter: d_1	Order No
3	= 1
4	= 2
5	= 3
6	= 4
8	= 5
10	= 6
13	= 7
16	= 8
20	= 9
25	= 10
32	= 11

Ordering Code (example):

2 2 4 1 . 7 G 4 . 0 6 5 0 . 0 4 5 0 . A

- Angle = 0° (A)
- Format: Slot, width W = 4.5 mm (0450)
- Format: Slot, length P = 6.5 mm (0650)
- Punch cutting length: l_1 = 19 mm (4)
- Length: l = 100 mm (G)
- Diameter: d_1 = 13 mm (7)
- Type: ISO (1)
- Version: Slot (4)
- Punch without ejector pin (22)

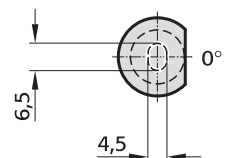
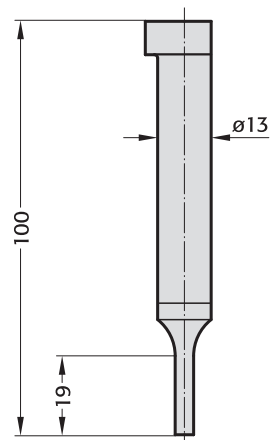

PUNCH, BLANK, ISO 8020

2201.

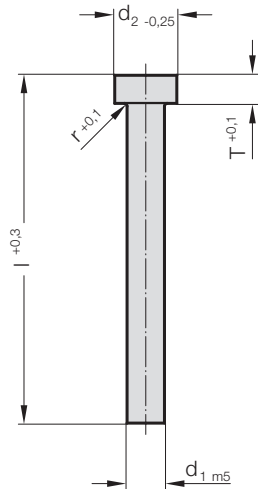

2201. Punch, blank, ISO 8020

d ₁ / Order No	d ₂	r	T	l / (Order Code character)	71 (D)	80 (E)	90 (F)	100 (G)	120 (J)	150 (M)	200 (N)
3 / (1)	5	0.25	3		●	●	●	●	●		
4 / (2)	6	0.25	3		●	●	●	●	●		
5 / (3)	8	0.3	5		●	●	●	●	●		
6 / (4)	9	0.3	5		●	●	●	●	●		
8 / (5)	11	0.3	5		●	●	●	●	●		
10 / (6)	13	0.3	5		●	●	●	●	●	●	
13 / (7)	16	0.4	5		●	●	●	●	●	●	
16 / (8)	19	0.4	5		●	●	●	●	●	●	●
20 / (9)	23	0.4	5		●	●	●	●	●	●	●
25 / (10)	28	0.4	5		●	●	●	●	●	●	●
32 / (11)	35	0.4	5		●	●	●	●	●	●	●

Ordering Code (example):

2201.7G.ASP

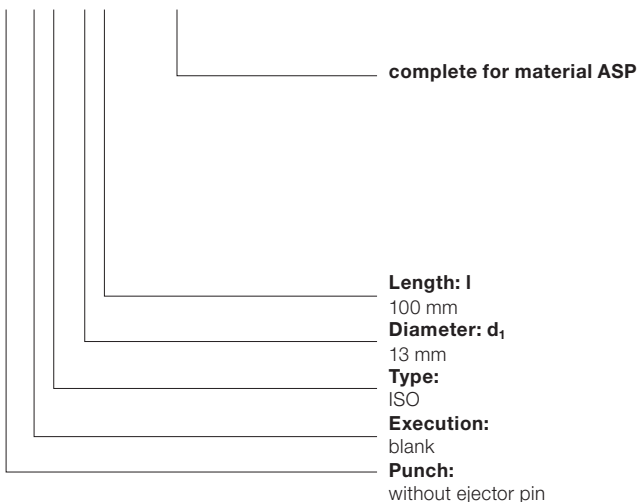

Material:

HSS
 Hardness:
 Shaft 64 ± 2 HRC
 Head 52 ± 5 HRC

ASP 23 - ASP 2023
 upon request

Description of FIBRO materials for tool and die components see at the beginning of Chapter E.

Execution:

Punch head hot upset-forged. Shoulder and shaft fine ground.
 Special dimensions on request.

PUNCH, STEPPED, ROUND, ISO 8020



2211.

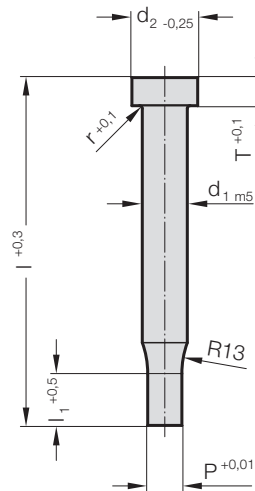

2211. Punch, stepped, round, ISO 8020

d ₁ / Order No	d ₂	P	l ₁ / Order No	r	T	l / (Order Code character)	71 (D)	80 (E)	90 (F)	100 (G)	120 (J)
3 / (1)	5	0,8 - 2,9	8 (1) 10 (2)	0,25	3		●	●	●	●	●
4 / (2)	6	1 - 3,9	8 (1) 13 (3)	0,25	3		●	●	●	●	●
5 / (3)	8	1,5 - 4,9	13 (3) 19 (4)	0,3	5		●	●	●	●	●
6 / (4)	9	1,6 - 5,9	13 (3) 19 (4)	0,3	5		●	●	●	●	●
8 / (5)	11	2,5 - 7,9	19 (4) 25 (5)	0,3	5		●	●	●	●	●
10 / (6)	13	4 - 9,9	19 (4) 25 (5)	0,3	5		●	●	●	●	●
13 / (7)	16	5 - 12,9	19 (4) 25 (5)	0,4	5		●	●	●	●	●
16 / (8)	19	8 - 15,9	19 (4) 25 (5)	0,4	5		●	●	●	●	●
20 / (9)	23	12 - 19,9	19 (4) 25 (5)	0,4	5		●	●	●	●	●
25 / (10)	28	16,5 - 24,9	19 (4) 25 (5)	0,4	5		●	●	●	●	●
32 / (11)	35	20 - 31,9	25 (5) 30 (6)	0,4	5		●	●	●	●	●

Material:

HSS

Hardness:

Shaft 64 ± 2 HRC

Head 52 ± 5 HRC

ASP 23 - ASP 2023

upon request

Description of FIBRO materials for tool and die components see at the beginning of Chapter E.

Execution:

Punch head hot upset-forged. Shoulder, shaft and punch diameter fine ground.

Special dimensions on request.

Ordering Code (example):

2211.7G4.0720

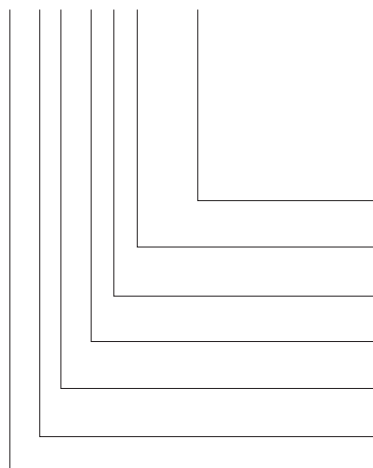

Shape: round

P = ∅ 7,2 mm

Punch cutting length: l₁

19 mm

Length: l

100 mm

Diameter: d₁

13 mm

Type:

ISO

Execution:

round

Punch:

without ejector pin

= 0720

Order No

= (4)

Order Code character

= (G)

Order No

= (7)

Order No

= (1)

Order No

= (1)

= 22

PUNCH, STEPPED, SQUARE, ISO 8020

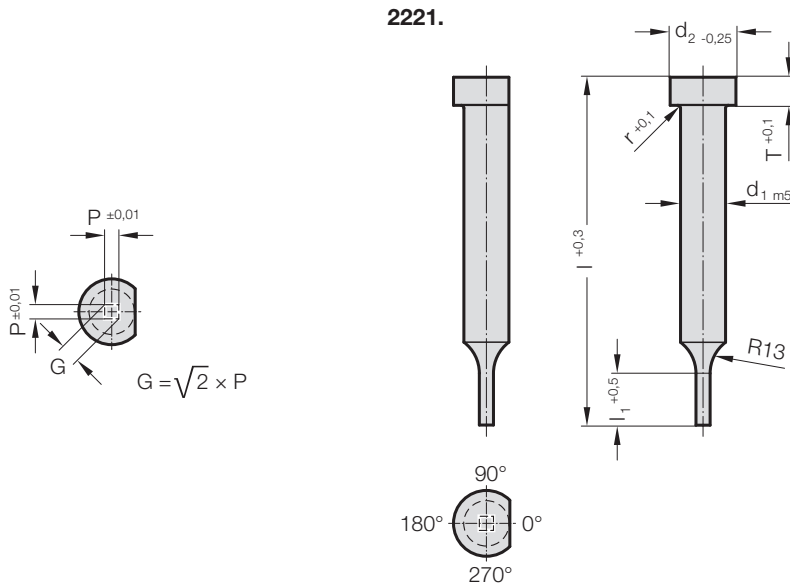

2221. Punch, stepped, square, ISO 8020

d_1 / Order No	d_2	P_{min}	G_{max}	l_1 / Order No	r	T	l / (Order Code character)	71 (D)	80 (E)	90 (F)	100 (G)	120 (J)
3 / (1)	5	0.5	2.9	8 (1) 10 (2)	0.25	3		●	●	●	●	●
4 / (2)	6	0.8	3.9	8 (1) 13 (3)	0.25	3		●	●	●	●	●
5 / (3)	8	1	4.9	13 (3) 19 (4)	0.3	5		●	●	●	●	●
6 / (4)	9	1.6	5.9	13 (3) 19 (4)	0.3	5		●	●	●	●	●
8 / (5)	11	2	7.9	19 (4) 25 (5)	0.3	5		●	●	●	●	●
10 / (6)	13	3.5	9.9	19 (4) 25 (5)	0.3	5		●	●	●	●	●
13 / (7)	16	4.5	12.9	19 (4) 25 (5)	0.4	5		●	●	●	●	●
16 / (8)	19	6	15.9	19 (4) 25 (5)	0.4	5		●	●	●	●	●
20 / (9)	23	8	19.9	19 (4) 25 (5)	0.4	5		●	●	●	●	●
25 / (10)	28	10	24.9	19 (4) 25 (5)	0.4	5		●	●	●	●	●
32 / (11)	35	10	31.9	25 (5) 30 (6)	0.4	5		●	●	●	●	●

Ordering Code (example):

2221.9E5.1550.B

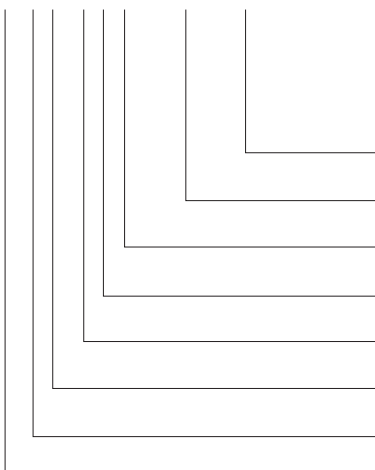

Angle:
90°
Shape: square, Length P
P = 15,5 mm
Punch cutting length: l_1
25 mm
Length: l
80 mm
Diameter: d_1
20 mm
Type:
ISO
Execution:
square
Punch:
without ejector pin

Order Code character
= (B)
Order No
= 1550
Order Code character
= (E)
Order No
= (9)
Order No
= (1)
Order No
= (2)
Order No
= 22

Material:

HSS
Hardness:
Shaft 64 ± 2 HRC
Head 52 ± 5 HRC

ASP 23 - ASP 2023
upon request

Description of FIBRO materials for tool and die components see at the beginning of Chapter E.

Execution:

Punch head hot upset-forged. Shoulder, shaft and punch shape fine ground.
The anti-rotation surface parallel to $P = 0^\circ$ as standard.
Special dimensions on request.

Note:

With kerf ≤ 0.04 mm, FIBRO rounds off sharp edges if the punch and piercing die bush are ordered together. This reduces the fitting time and the risk of an edge break during operation.

PUNCH, STEPPED, RECTANGULAR, ISO 8020



2231.

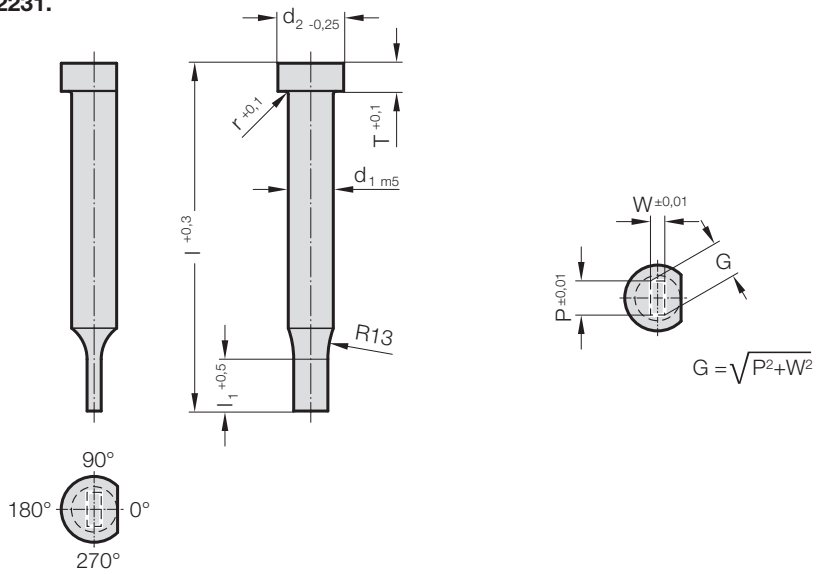

2231. Punch, stepped, rectangular, ISO 8020

d ₁ / Order No	d ₂	W _{min}	G _{max}	l ₁ / Order No	r	T	l / (Order Code character)	71 (D)	80 (E)	90 (F)	100 (G)	120 (J)
3 / (1)	5	0.5	2.9	8 (1) 10 (2)	0.25	3		●	●	●	●	●
4 / (2)	6	0.8	3.9	8 (1) 13 (3)	0.25	3		●	●	●	●	●
5 / (3)	8	1	4.9	13 (3) 19 (4)	0.3	5		●	●	●	●	●
6 / (4)	9	1.6	5.9	13 (3) 19 (4)	0.3	5		●	●	●	●	●
8 / (5)	11	2	7.9	19 (4) 25 (5)	0.3	5		●	●	●	●	●
10 / (6)	13	3.5	9.9	19 (4) 25 (5)	0.3	5		●	●	●	●	●
13 / (7)	16	4.5	12.9	19 (4) 25 (5)	0.4	5		●	●	●	●	●
16 / (8)	19	6	15.9	19 (4) 25 (5)	0.4	5		●	●	●	●	●
20 / (9)	23	8	19.9	19 (4) 25 (5)	0.4	5		●	●	●	●	●
25 / (10)	28	10	24.9	19 (4) 25 (5)	0.4	5		●	●	●	●	●
32 / (11)	35	10	31.9	25 (5) 30 (6)	0.4	5		●	●	●	●	●

Material:

HSS

Hardness:

Shaft 64 ± 2 HRC

Head 52 ± 5 HRC

ASP 23 - ASP 2023

upon request

Description of FIBRO materials for tool and die components see at the beginning of Chapter E.

Execution:

Punch head hot upset-forged. Shoulder, shaft and punch shape fine ground.

The anti-rotation surface parallel to P = 0° as standard.

Special dimensions on request.

Note:

With kerf ≤ 0.04 mm, FIBRO rounds off sharp edges if the punch and piercing die bush are ordered together. This reduces the fitting time and the risk of an edge break during operation.

Ordering Code (example):

2231.9F4.1550.1150.B

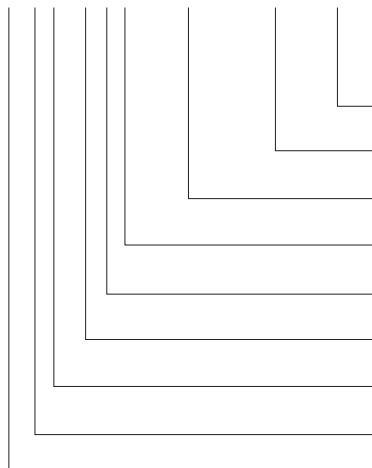

Angle:

90°

Shape: rectangular, Width W

W = 11,5 mm

Shape: rectangular, Length P

P = 15,5 mm

Punch cutting length: l₁

19 mm

Length: l

90 mm

Diameter: d₁

20 mm

Type:

ISO

Execution:

rectangular

Punch:

without ejector pin

Order Code character
= (B)

= 1150

= 1550

Order No

= (4)

Order Code character

= (F)

Order No

= (9)

Order No

= (1)

Order No

= (3)

= 22

PUNCH, STEPPED, SLOT, ISO 8020

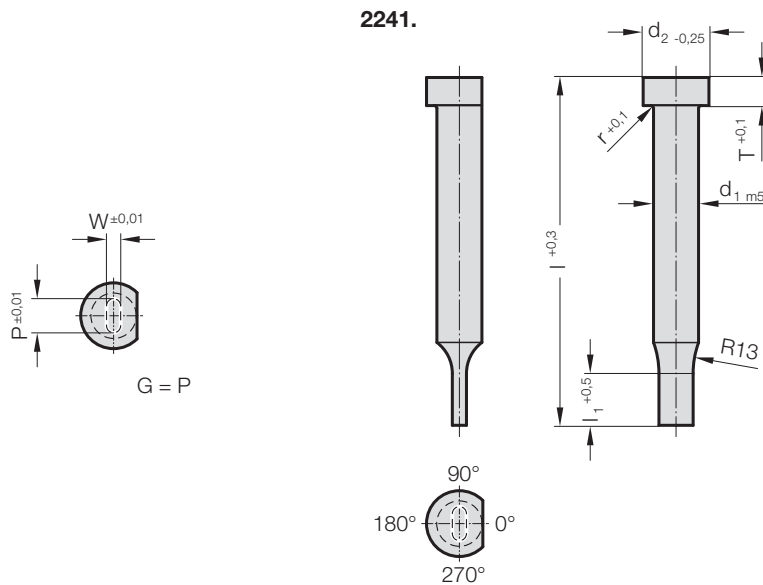

2241. Punch, stepped, slot, ISO 8020

d ₁ / Order No	d ₂	W _{min}	G _{max}	l ₁ / Order No	r	T	l / (Order Code character)	71 (D)	80 (E)	90 (F)	100 (G)	120 (J)
3 / (1)	5	0.5	2.9	8 (1) 10 (2)	0.25	3		●	●	●	●	●
4 / (2)	6	0.8	3.9	8 (1) 13 (3)	0.25	3		●	●	●	●	●
5 / (3)	8	1	4.9	13 (3) 19 (4)	0.3	5		●	●	●	●	●
6 / (4)	9	1.6	5.9	13 (3) 19 (4)	0.3	5		●	●	●	●	●
8 / (5)	11	2	7.9	19 (4) 25 (5)	0.3	5		●	●	●	●	●
10 / (6)	13	3.5	9.9	19 (4) 25 (5)	0.3	5		●	●	●	●	●
13 / (7)	16	4.5	12.9	19 (4) 25 (5)	0.4	5		●	●	●	●	●
16 / (8)	19	6	15.9	19 (4) 25 (5)	0.4	5		●	●	●	●	●
20 / (9)	23	8	19.9	19 (4) 25 (5)	0.4	5		●	●	●	●	●
25 / (10)	28	10	24.9	19 (4) 25 (5)	0.4	5		●	●	●	●	●
32 / (11)	35	10	31.9	25 (5) 30 (6)	0.4	5		●	●	●	●	●

Ordering Code (example):

2241.9E5.1650.1220.B

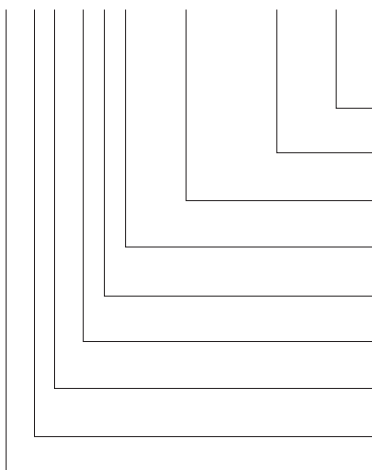

Angle:
90°
Shape: slot, Width W
W = 12,2 mm
Shape: slot, Length P
P = 16,5 mm
Punch cutting length: l₁
25 mm
Length: l
80 mm
Diameter: d₁
20 mm
Type:
ISO
Execution:
slot
Punch:
without ejector pin

Order Code character
= (B)
= 1220
= 1650
Order No
= (5)
Order Code character
= (E)
Order No
= (9)
Order No
= (1)
Order No
= (4)
= 22

Material:

HSS
Hardness:
Shaft 64 ± 2 HRC
Head 52 ± 5 HRC

ASP 23 - ASP 2023
upon request

Description of FIBRO materials for tool and die components see at the beginning of Chapter E.

Execution:

Punch head hot upset-forged. Shoulder, shaft and punch shape fine ground.
The anti-rotation surface parallel to P = 0° as standard.
Special dimensions on request.

PUNCH, STEPPED, RECTANGLE WITH RADIUSED CORNERS, ISO 8020



2251.

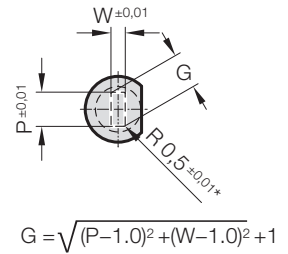
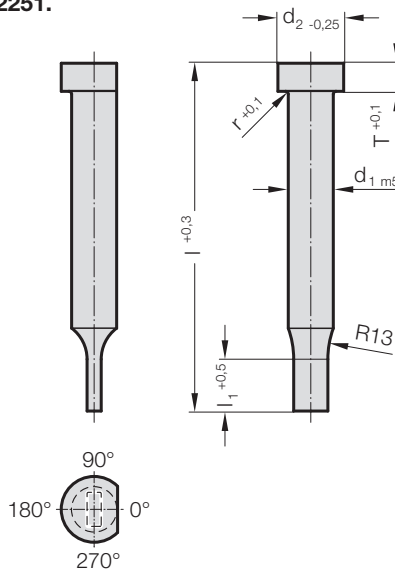

2251. Punch, stepped, rectangle with radiused corners, ISO 8020

d ₁ / Order No	d ₂	W _{min}	G _{max}	l ₁ / Order No	r	T	l / (Order Code character)	71 (D)	80 (E)	90 (F)	100 (G)	120 (J)
3 / (1)	5	1.1	2.9	8 (1) 10 (2)	0.25	3		●	●	●	●	●
4 / (2)	6	1.1	3.9	8 (1) 13 (3)	0.25	3		●	●	●	●	●
5 / (3)	8	1.1	4.9	13 (3) 19 (4)	0.3	5		●	●	●	●	●
6 / (4)	9	1.6	5.9	13 (3) 19 (4)	0.3	5		●	●	●	●	●
8 / (5)	11	2	7.9	19 (4) 25 (5)	0.3	5		●	●	●	●	●
10 / (6)	13	3.5	9.9	19 (4) 25 (5)	0.3	5		●	●	●	●	●
13 / (7)	16	4.5	12.9	19 (4) 25 (5)	0.4	5		●	●	●	●	●
16 / (8)	19	6	15.9	19 (4) 25 (5)	0.4	5		●	●	●	●	●
20 / (9)	23	8	19.9	19 (4) 25 (5)	0.4	5		●	●	●	●	●
25 / (10)	28	10	24.9	19 (4) 25 (5)	0.4	5		●	●	●	●	●
32 / (11)	35	10	31.9	25 (5) 30 (6)	0.4	5		●	●	●	●	●

Material:

HSS

Hardness:

Shaft 64 ± 2 HRC

Head 52 ± 5 HRC

ASP 23 - ASP 2023

upon request

☞ Description of FIBRO materials for tool and die components see at the beginning of Chapter E.

Execution:

Punch head hot upset-forged. Shoulder, shaft and punch shape fine ground.

The anti-rotation surface parallel to P = 0° as standard.

Special dimensions on request.

* For other radius options, see standardised special shapes.

Ordering Code (example):

2251.9F4.1215.1150.B

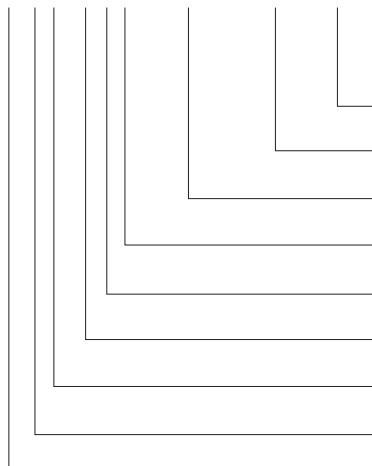

Angle:

90°

Shape: rectangle with radiused corners, Width W

W = 11,5 mm

Shape: rectangle with radiused corners, Length P

P = 12,15 mm

Punch cutting length: l₁

19 mm

Length: l

90 mm

Diameter: d₁

20 mm

Type:

ISO

Execution:

rectangle with radiused corners

Punch:

without ejector pin

Order Code character

= (B)

Order Code character

= 1150

Order Code character

= 1215

Order No

= (4)

Order Code character

= (F)

Order No

= (9)

Order No

= (1)

Order No

= (5)

= 22

PUNCH, BLANK, WITH EJECTOR PIN, ISO 8020

2701.

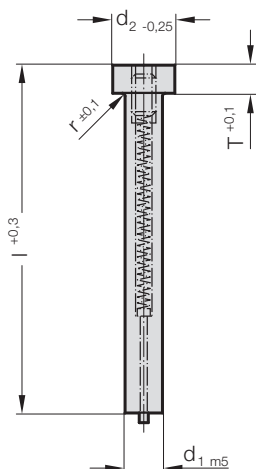

2701. Punch, blank, with ejector pin, ISO 8020

d ₁ / Order No	d ₂	r	T	l / (Order Code character)	71 (D)	80 (E)	90 (F)	100 (G)	120 (J)
5 / (3)	8	0.3	5		●	●	●	●	●
6 / (4)	9	0.3	5		●	●	●	●	●
8 / (5)	11	0.3	5		●	●	●	●	●
10 / (6)	13	0.3	5		●	●	●	●	●
13 / (7)	16	0.4	5		●	●	●	●	●
16 / (8)	19	0.4	5		●	●	●	●	●
20 / (9)	23	0.4	5		●	●	●	●	●
25 / (10)	28	0.4	5		●	●	●	●	●
32 / (11)	35	0.4	5		●	●	●	●	●

Ordering Code (example):

2701.8G

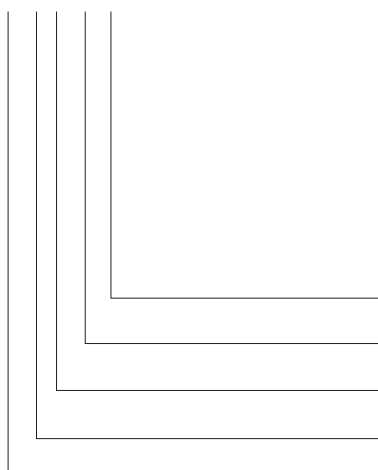

Length: l
100 mm
Diameter: d₁
16 mm
Type:
ISO
Execution:
blank
Punch:
with ejector pin

Order Code character
= (G)
Order No
= (8)
Order No
= (1)
Order No
= (0)
= 27

Material:

HSS
Hardness:
Shaft 64 ± 2 HRC
Head 52 ± 5 HRC

Execution:

Punch head hot upset-forged. Shoulder and shaft fine ground.
Special dimensions on request.

PUNCH, STEPPED, ROUND, WITH EJECTOR PIN, ISO 8020



2711.

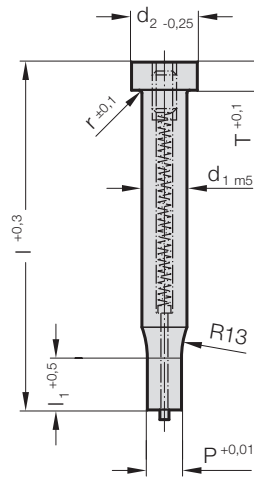

2711. Punch, stepped, round, with ejector pin, ISO 8020

d ₁ / Order No	d ₂	P	l ₁ / Order No	r	T	l / (Order Code character)	71 (D)	80 (E)	90 (F)	100 (G)	120 (J)
5 / (3)	8	2 - 4,9	13 (3) 19 (4)	0.3	5		●	●	●	●	●
6 / (4)	9	2,5 - 5,9	13 (3) 19 (4)	0.3	5		●	●	●	●	●
8 / (5)	11	4 - 7,9	19 (4) 25 (5)	0.3	5		●	●	●	●	●
10 / (6)	13	5 - 9,9	19 (4) 25 (5)	0.3	5		●	●	●	●	●
13 / (7)	16	6 - 12,9	19 (4) 25 (5)	0.4	5		●	●	●	●	●
16 / (8)	19	8 - 15,9	19 (4) 25 (5)	0.4	5		●	●	●	●	●
20 / (9)	23	10 - 19,9	19 (4) 25 (5)	0.4	5		●	●	●	●	●
25 / (10)	28	12 - 24,9	19 (4) 25 (5)	0.4	5		●	●	●	●	●
32 / (11)	35	16 - 31,9	25 (5) 30 (6)	0.4	5		●	●	●	●	●

Material:

HSS

Hardness:

Shaft 64 ± 2 HRC

Head 52 ± 5 HRC

Execution:

Punch head hot upset-forged. Shoulder, shaft and punch diameter fine ground.

Special dimensions on request.

Ordering Code (example):

2711.7G4.0720

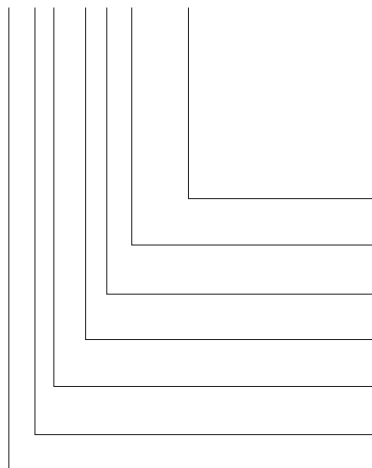

Shape: round

P = ∅ 7,2 mm

Punch cutting length: l₁
19 mm

Length: l

100 mm

Diameter: d₁

13 mm

Type:

ISO

Execution:

round

Punch:

with ejector pin

= 0720

Order No

= (4)

Order Code character

= (G)

Order No

= (7)

Order No

= (1)

Order No

= (1)

= 27

PUNCH, STEPPED, SQUARE, WITH EJECTOR PIN, ISO 8020

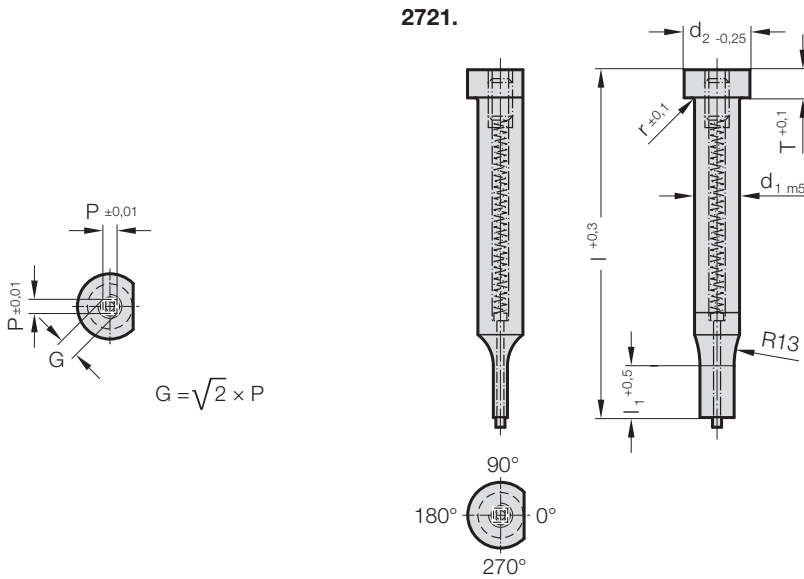

2721. Punch, stepped, square, with ejector pin, ISO 8020

d ₁ / Order No	d ₂	P _{min}	G _{max}	l ₁ / Order No	r	T	l / (Order Code character)	71 (D)	80 (E)	90 (F)	100 (G)	120 (J)
5 / (3)	8	2	4.9	13 (3) 19 (4)	0.3	5		●	●	●	●	●
6 / (4)	9	2.5	5.9	13 (3) 19 (4)	0.3	5		●	●	●	●	●
8 / (5)	11	4	7.9	19 (4) 25 (5)	0.3	5		●	●	●	●	●
10 / (6)	13	4	9.9	19 (4) 25 (5)	0.3	5		●	●	●	●	●
13 / (7)	16	6	12.9	19 (4) 25 (5)	0.4	5		●	●	●	●	●
16 / (8)	19	8	15.9	19 (4) 25 (5)	0.4	5		●	●	●	●	●
20 / (9)	23	10	19.9	19 (4) 25 (5)	0.4	5		●	●	●	●	●
25 / (10)	28	12	24.9	19 (4) 25 (5)	0.4	5		●	●	●	●	●
32 / (11)	35	16	31.9	25 (5) 30 (6)	0.4	5		●	●	●	●	●

Ordering Code (example):

2721.9E5.1550.A

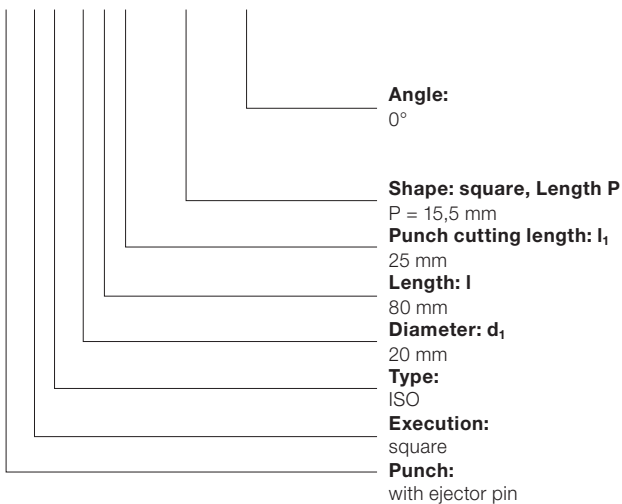

Order Code character
= (A)

= 1550
Order No

= (5)
Order Code character

= (E)
Order No

= (9)
Order No

= (1)
Order No

= (2)
Order No

= 27

Material:

HSS
Hardness:
Shaft 64 ± 2 HRC
Head 52 ± 5 HRC

Execution:

Punch head hot upset-forged. Shoulder, shaft and punch shape fine ground.
The anti-rotation surface parallel to P = 0° as standard.
Special dimensions on request.

Note:

With kerf ≤ 0.04 mm, FIBRO rounds off sharp edges if the punch and piercing die bush are ordered together. This reduces the fitting time and the risk of an edge break during operation.

PUNCH, STEPPED, RECTANGULAR, WITH EJECTOR PIN, ISO 8020



2731.

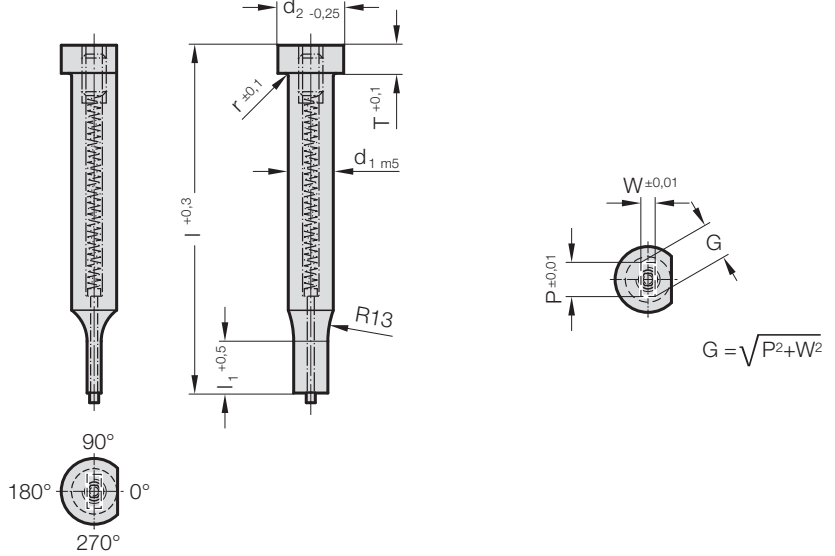

2731. Punch, stepped, rectangular, with ejector pin, ISO 8020

d_1 / Order No	d_2	W_{min}	G_{max}	l_1 / Order No	r	T	l / (Order Code character)	71 (D)	80 (E)	90 (F)	100 (G)	120 (J)
5 / (3)	8	2	4.9	13 (3) 19 (4)	0.3	5		●	●	●	●	●
6 / (4)	9	2.5	5.9	13 (3) 19 (4)	0.3	5		●	●	●	●	●
8 / (5)	11	4	7.9	19 (4) 25 (5)	0.3	5		●	●	●	●	●
10 / (6)	13	4	9.9	19 (4) 205 (5)	0.3	5		●	●	●	●	●
13 / (7)	16	6	12.9	19 (4) 25 (5)	0.4	5		●	●	●	●	●
16 / (8)	19	8	15.9	19 (4) 25 (5)	0.4	5		●	●	●	●	●
20 / (9)	23	10	19.9	19 (4) 25 (5)	0.4	5		●	●	●	●	●
25 / (10)	28	12	24.9	19 (4) 25 (5)	0.4	5		●	●	●	●	●
32 / (11)	35	16	31.9	25 (5) 30 (6)	0.4	5		●	●	●	●	●

Material:

HSS

Hardness:

Shaft 64 ± 2 HRC

Head 52 ± 5 HRC

Execution:

Punch head hot upset-forged. Shoulder, shaft and punch shape fine ground.

The anti-rotation surface parallel to $P = 0^\circ$ as standard.

Special dimensions on request.

Note:

With kerf ≤ 0.04 mm, FIBRO rounds off sharp edges if the punch and piercing die bush are ordered together. This reduces the fitting time and the risk of an edge break during operation.

Ordering Code (example):

2731.9F4.1550.1150.A

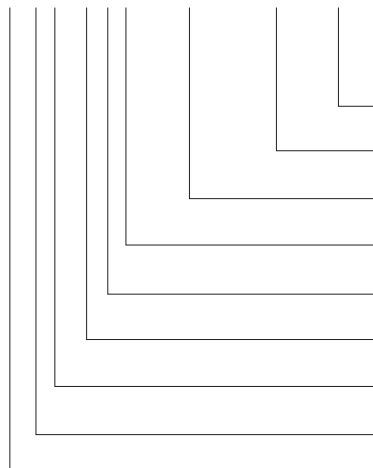

Angle:

0°

Shape: rectangular, Width W

$W = 11,5$ mm

Shape: rectangular, Length P

$P = 15,5$ mm

Punch cutting length: l_1

19 mm

Length: l

90 mm

Diameter: d_1

20 mm

Type:

ISO

Execution:

rectangular

Punch:

with ejector pin

Order Code character
= (A)

= 1150

= 1550

Order No

= (4)

Order Code character

= (F)

Order No

= (9)

Order No

= (1)

Order No

= (3)

= 27

PUNCH, STEPPED, SLOT, WITH EJECTOR PIN, ISO 8020

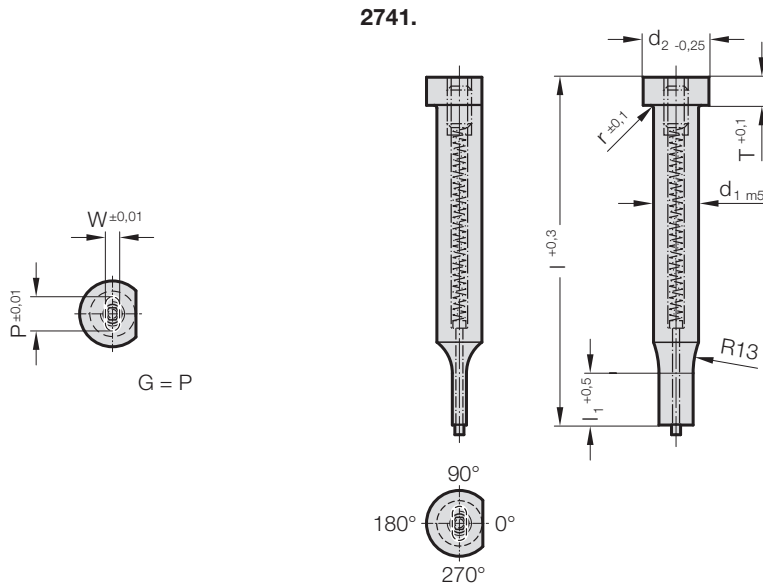

2741. Punch, stepped, slot, with ejector pin, ISO 8020

d_1 / Order No	d_2	W_{min}	G_{max}	l_1 / Order No	r	T	l / (Order Code character)	71 (D)	80 (E)	90 (F)	100 (G)	120 (J)
5 / (3)	8	2	4.9	13 (3) 19 (4)	0.3	5		●	●	●	●	●
6 / (4)	9	2.5	5.9	13 (3) 19 (4)	0.3	5		●	●	●	●	●
8 / (5)	11	4	7.9	19 (4) 25 (5)	0.3	5		●	●	●	●	●
10 / (6)	13	4	9.9	19 (4) 25 (5)	0.3	5		●	●	●	●	●
13 / (7)	16	6	12.9	19 (4) 25 (5)	0.4	5		●	●	●	●	●
16 / (8)	19	8	15.9	19 (4) 25 (5)	0.4	5		●	●	●	●	●
20 / (9)	23	10	19.9	19 (4) 25 (5)	0.4	5		●	●	●	●	●
25 / (10)	28	12	24.9	19 (4) 25 (5)	0.4	5		●	●	●	●	●
32 / (11)	35	16	31.9	25 (5) 30 (6)	0.4	5		●	●	●	●	●

Ordering Code (example):

2741.9E5.1650.1220.B

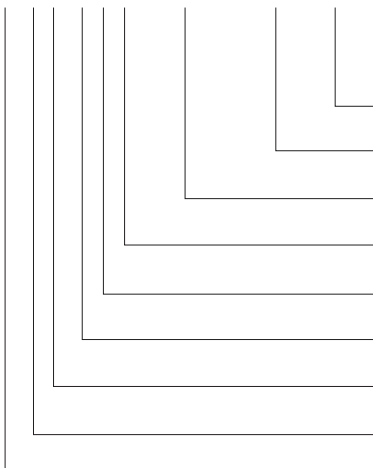

Angle:
90°
Shape: slot, Width W
W = 12,2 mm
Shape: slot, Length P
P = 16,5 mm
Punch cutting length: l_1
25 mm
Length: l
80 mm
Diameter: d_1
20 mm
Type:
ISO
Execution:
slot
Punch:
with ejector pin

Order Code character
= (B)
= 1220
= 1650
Order No
= (5)
Order Code character
= (E)
Order No
= (9)
Order No
= (1)
Order No
= (4)
= 27

Material:

HSS
Hardness:
Shaft 64 ± 2 HRC
Head 52 ± 5 HRC

Execution:

Punch head hot upset-forged. Shoulder, shaft and punch shape fine ground.
The anti-rotation surface parallel to P = 0° as standard.
Special dimensions on request.

PUNCH, STEPPED, RECTANGLE WITH RADIUSSED CORNERS, WITH EJECTOR PIN, ISO 8020



2751.

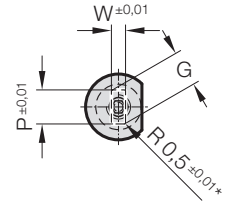
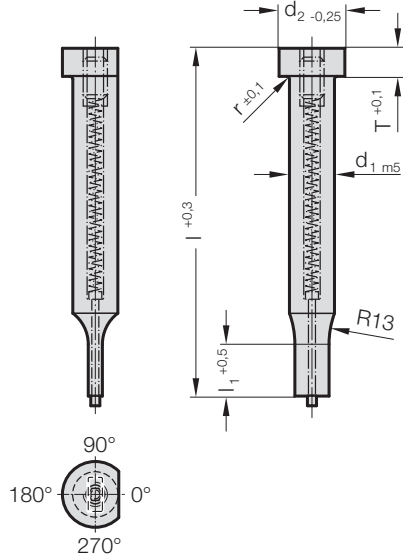

$$G = \sqrt{(P-1.0)^2 + (W-1.0)^2} + 1$$

2751. Punch, stepped, rectangle with radiused corners, with ejector pin, ISO 8020

d ₁ / Order No	d ₂	W _{min}	G _{max}	l ₁ / Order No	r	T	l / (Order Code character)	71 (D)	80 (E)	90 (F)	100 (G)	120 (J)
5 / (3)	8	2	4.9	13 (3) 19 (4)	0.3	5		●	●	●	●	●
6 / (4)	9	2.5	5.9	13 (3) 19 (4)	0.3	5		●	●	●	●	●
8 / (5)	11	4	7.9	19 (4) 25 (5)	0.3	5		●	●	●	●	●
10 / (6)	13	4	9.9	19 (4) 25 (5)	0.3	5		●	●	●	●	●
13 / (7)	16	6	12.9	19 (4) 25 (5)	0.4	5		●	●	●	●	●
16 / (8)	19	8	15.9	19 (4) 25 (5)	0.4	5		●	●	●	●	●
20 / (9)	23	10	19.9	19 (4) 25 (5)	0.4	5		●	●	●	●	●
25 / (10)	28	12	24.9	19 (4) 25 (5)	0.4	5		●	●	●	●	●
32 / (11)	35	16	31.9	25 (5) 30 (6)	0.4	5		●	●	●	●	●

Material:

HSS

Hardness:

Shaft 64 ± 2 HRC

Head 52 ± 5 HRC

Execution:

Punch head hot upset-forged. Shoulder, shaft and punch shape fine ground.

The anti-rotation surface parallel to P = 0° as standard.

Special dimensions on request.

* For other radius options, see standardised special shapes.

Ordering Code (example):

2751.9F4.1550.1150.A

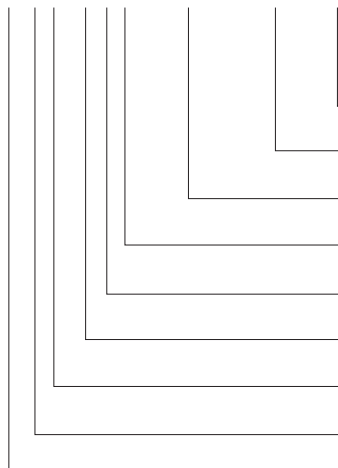

Angle:

0°

Shape: rectangle with radiused corners, Width W

W = 11,5 mm

Shape: rectangle with radiused corners, Length P

P = 15,5 mm

Punch cutting length: l₁

19 mm

Length: l

90 mm

Diameter: d₁

20 mm

Type:

ISO

Execution:

rectangle with radiused corners

Punch:

with ejector pin

Order Code character
= (A)

Order Code character
= 1150

Order Code character
= 1550

Order No
= (4)

Order Code character
= (F)

Order No
= (9)

Order No
= (1)

Order No
= (5)

Order No
= 27

PILOT PIN WITH TAPERED TIP, ISO 8020

2261.

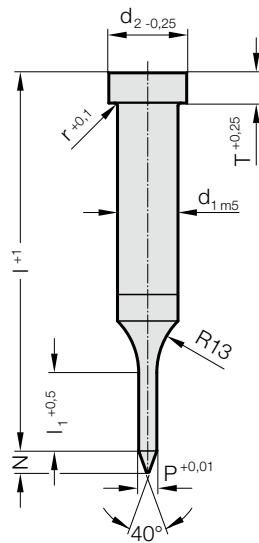

2261. Pilot pin with tapered tip, ISO 8020

d ₁ / Order No	d ₂	T	P	l ₁ / Order No	N	l / (Order Code character)	63 (C)	71 (D)	80 (E)	90 (F)	100 (G)	110 (H)	125 (K)	140 (L)
5 / (3)	8	5	1 - 4,9	13 (3)	4		●	●						
6 / (4)	9	5	1,6 - 5,9	13 (3)	5		●	●	●					
8 / (5)	11	5	2,5 - 7,9	13 (3)	6		●	●	●	●				
10 / (6)	13	5	4 - 9,9	13 (3) 19 (4)	8		●	●	●	●	●			
13 / (7)	16	5	5 - 12,9	13 (3) 19 (4)	10		●	●	●	●	●	●		
16 / (8)	19	5	8 - 15,9	13 (3) 19 (4) 25 (5)	15		●	●	●	●	●	●	●	
20 / (9)	23	5	12 - 19,9	13 (3) 19 (4) 25 (5)	20		●	●	●	●	●	●	●	●
25 / (10)	28	5	16,5 - 24,9	13 (3) 19 (4) 25 (5)	25		●	●	●	●	●	●	●	●
32 / (11)	35	5	20 - 31,9	19 (4) 25 (5)	30		●	●	●	●	●	●	●	●

Ordering Code (example):

2261.6G3.0710

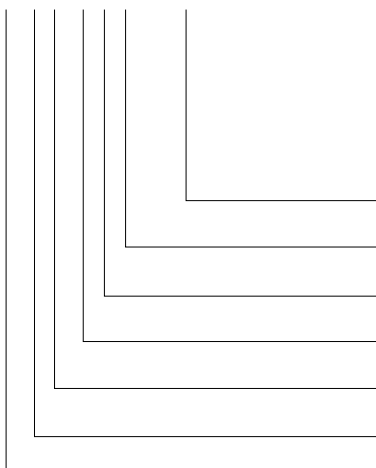

Shape: round

P = Ø 7,1 mm

Punch cutting length: l₁

13 mm

Length: l

100 mm

Diameter: d₁

10 mm

Type:

ISO

Execution:

Pilot pin with tapered tip

Punch:

without ejector pin

= 0710

Order No

= (3)

Order Code character

= (G)

Order No

= (6)

Order No

= (1)

Order No

= (6)

= 22

Material:

HSS

Hardness:

Shaft 64 ± 2 HRC

Head 52 ± 5 HRC

Execution:

Head hot upset-forged. Shoulder, shaft and pilot fine ground.

Special dimensions on request.

PILOT PIN WITH PARABOLIC TIP, ISO 8020



2271.

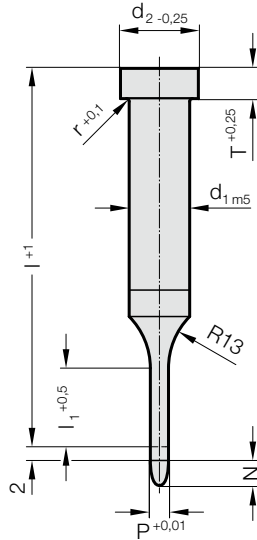

2271. Pilot pin with parabolic tip, ISO 8020

d ₁ / Order No	d ₂	T	P	l ₁ / Order No	l / (Order Code character)	50 (A)	56 (B)	63 (C)	71 (D)	80 (E)	90 (F)	100 (G)
5 / (3)	8	5	1 - 4,9	10 (2) 13 (3)		●	●	●	●			
6 / (4)	9	5	1,6 - 5,9	10 (2) 13 (3)		●	●	●	●	●		
8 / (5)	11	5	2,5 - 7,9	10 (2) 13 (3)		●	●	●	●	●		
10 / (6)	13	5	4 - 9,9	10 (2) 13 (3) 19 (4)		●	●	●	●	●	●	●
13 / (7)	16	5	5 - 12,9	10 (2) 13 (3) 19 (4)		●	●	●	●	●	●	●
16 / (8)	19	5	8 - 15,9	13 (3) 19 (4)		●	●	●	●	●	●	●
20 / (9)	23	5	12 - 19,9	13 (3) 19 (4)			●	●	●	●	●	●
25 / (10)	28	5	16,5 - 24,9	13 (3) 19 (4)			●	●	●	●	●	●
32 / (11)	35	5	20 - 31,9	19 (4)					●	●	●	●

Material:

HSS

Hardness:

Shaft 64 ± 2 HRC

Head 52 ± 5 HRC

Execution:

Head hot upset-forged. Shoulder, shaft and pilot fine ground.

Special dimensions on request.

Note:

The 2 mm length provides full guidance before the blanking punch contacts the sheet metal.

Length of parabolic tip N:

= 8 mm where P ≤ 10 mm

=12 mm where P 10,1 mm - 15 mm

=15 mm where P > 15 mm

Ordering Code (example):

2271.9F4.1870

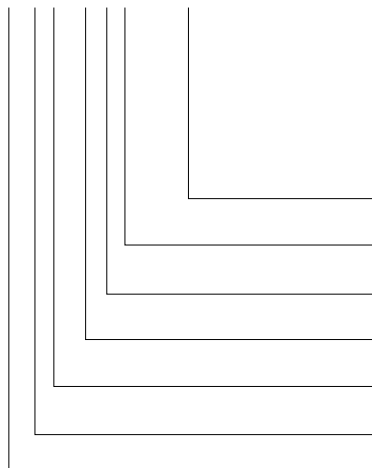

Shape: round

P = ∅ 18,7 mm

Punch cutting length: l₁
19 mm

Length: l

90 mm

Diameter: d₁

20 mm

Type:

ISO

Execution:

Pilot pin with parabolic tip

Punch:

without ejector pin

= 1870

Order No

= (4)

Order Code character

= (F)

Order No

= (9)

Order No

= (1)

Order No

= (7)

= 22

PILOT UNITS

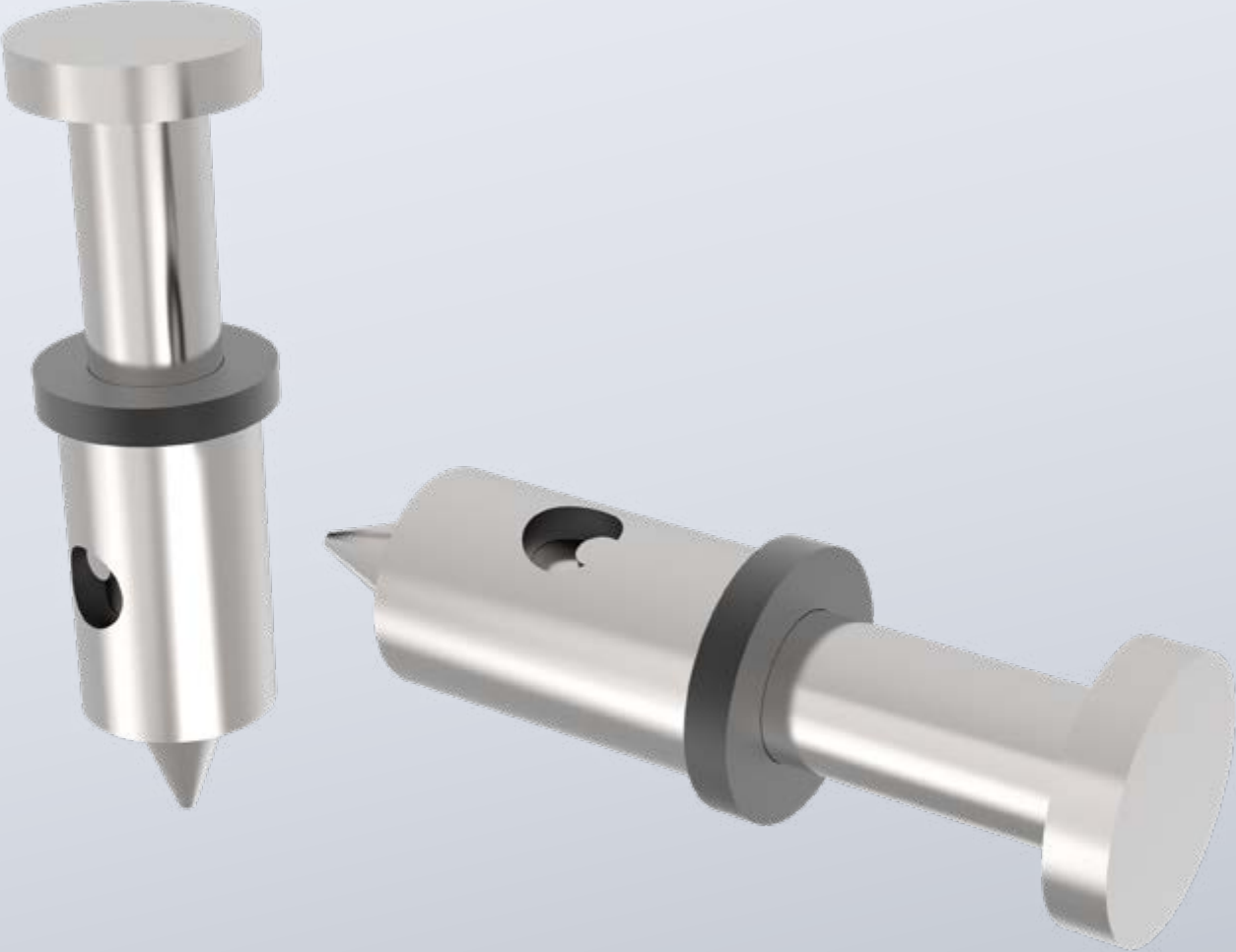

PILOT UNIT TO MERCEDES-BENZ STANDARD

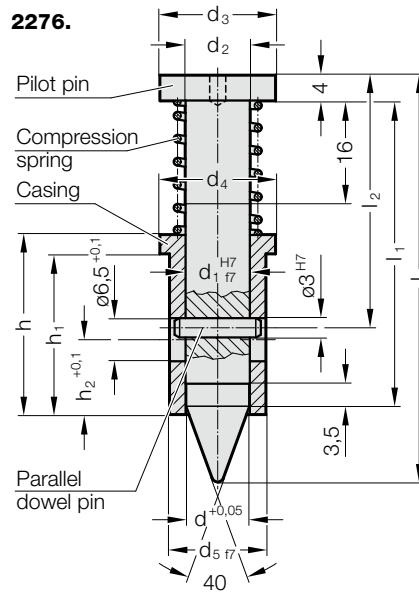

2276. Pilot unit to Mercedes-Benz Standard

Order No	d	d ₁	d ₂	d ₃	d ₄	d ₅	h	h ₁	h ₂	l ₁	l ₂	l	Spring force preloaded [daN]	Spring force pressed [daN]
2276.1.A.0980	9.8	10	10	18	18	15	28	25	12	47.5	39.3	63.2	4.9	6.2
2276.2.B.1580	15.8	16	16	24	30	26	28	25	12	54.5	46.3	72.5	4.8	5.6

Description:

The pilot unit provides exact positioning of sheet metal parts.

There are 2 sizes.

The pilot unit 10 (2276.1.) can be used for a hole diameter of 5 to 10 mm and is available as a finished item, 9.8 mm diameter.

The pilot unit 16 (2276.2.) is used for diameter > 10 - 16 mm and is available as a finished item, 15.8 mm diameter.

Smaller diameters have to be ground by the tool making department.

Material:

Sleeve: 1.3505

Hardness 58 ± 2 HRC

Pilot pin: 1.2550

Hardness 50 ± 2 HRC

Execution:

The pilot unit consists of:

Pilot pin, sleeve, compression spring, dowel pin.

Ordering Code (example):

2276.1.A.0980

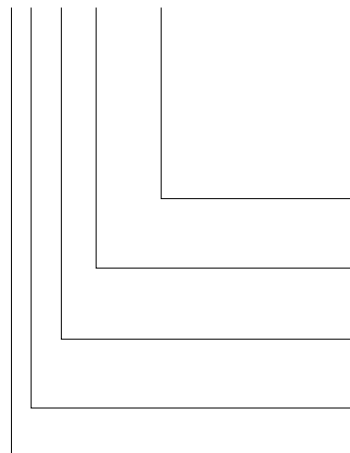

Diameter: d

9,8 mm

15,8 mm

Length: l

63,2 mm

72,5 mm

Diameter: d₁

10 mm

16 mm

Standard:

Mercedes

Execution:

Pilot pin

= 0980

= 1580

Order Code character

= (A)

= (B)

Order No

= (1)

= (2)

Order No

= (6)

Order No

= (7)

= 22

PUNCH GUIDE BUSHES

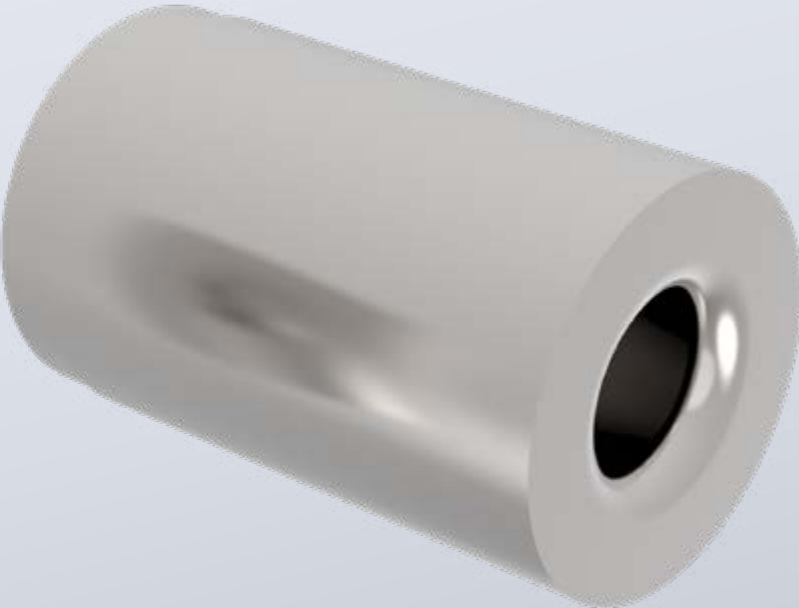

GUIDE BUSH FOR PUNCH, DIN 9845 SHAPE C



262.

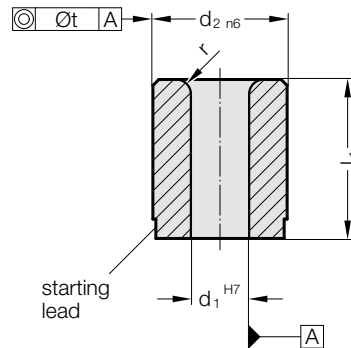

262. Guide bush for punch, DIN 9845 Shape C

d_1	Gradation	d_2	t	l_1	r
0,5 - 1	0,1	5	0,01	9	1
1,1 - 2	0,1	6	0,01	12	1
2,1 - 3	0,1	7	0,01	12	1
3,1 - 4	0,1	8	0,01	12	1
4,1 - 5	0,1	10	0,01	16	1
5,1 - 6	0,1	12	0,02	16	1,5
6,1 - 8	0,1	15	0,02	20	1,5
8,1 - 10	0,1	18	0,02	20	2
10,1 - 12	0,1	22	0,02	28	2
12,1 - 15	0,1	26	0,02	28	2
15,1 - 18	0,5	30	0,02	36	2

Material:

Case hardened steel
Hardness 740 ± 40 HV 10

Execution:

Diameters d_1 , d_2 and starting lead ground.

Ordering Code (example):

Guide bush for punch, DIN 9845 Shape C = 262.1.

Diameter of conduit d_1 5.1 mm = 0510.

Length l_1 16 mm = 016

Order No = 262.1. 0510. 016

GUIDE BUSH FOR PUNCH, ISO 8978

2621.

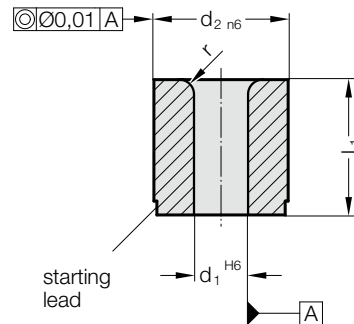

Material:

WS

Hardness 60 ± 2 HRC

Description of FIBRO materials for tool and die components see at the beginning of Chapter E.

Execution:

Diameters d_1 , d_2 and starting lead ground.

2621. Guide bush for punch, ISO 8978

Gradation				
d_1	d_1	d_2	l_1	r
1 - 2,4	0.1	5	8	1
1,6 - 3	0.1	6	12.5	1
2 - 3,5	0.1	8	12.5	1.5
3 - 5	0.1	10	16	2
4 - 7,2	0.1	13	16	2
6 - 8,8	0.1	16	20	2
7,5 - 11,3	0.1	20	20	2.5
11 - 16,6	0.1	25	25	2.5
15 - 20	0.5	32	25	4
18 - 27	0.5	40	32	4
26 - 36	0.5	50	40	4

Ordering Code (example):

Guide bush for punch, ISO 8978	=	2621.1.
Diameter of conduit d_1	6 mm =	0600.
Outer diameter d_2	16 mm =	1600
Order No	=	2621.1. 0600. 1600

MATRIXES ISO 8977

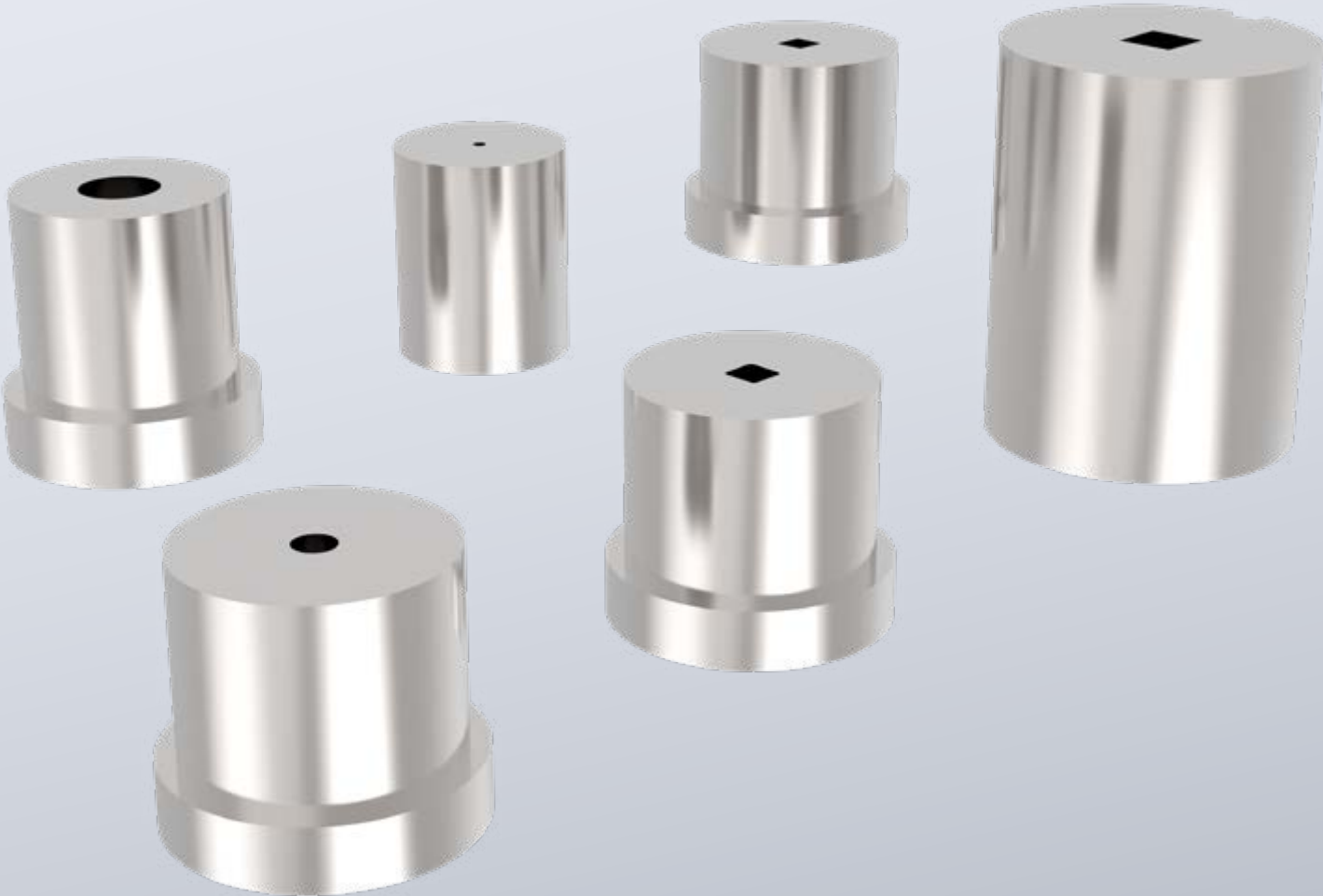

CUTTING BUSHINGS - ORDER EXAMPLE

Note: See table for standard dimensions
Special dimensions to order

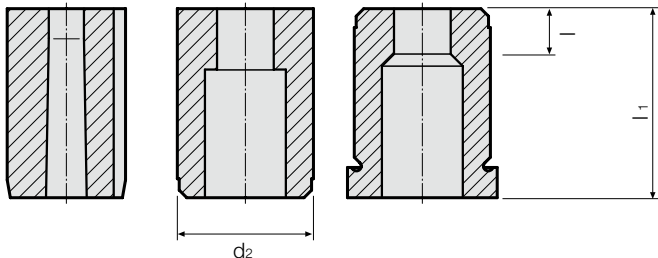

2 6 4 6 . 1 0 F 6 . 1 3 5 0 . 0 6 5 0 . A 2

Matrixes:
26 = matrixes

Execution:	Order No
○ blank (pilot hole bore)	= 0
○ round	= 1
□ square	= 2
▭ rectangular	= 3
○ slot	= 4
○ rectangle with radiused corners	= 5
special shapes	= 9

Type:	Order No
Automotive standard	= 5
without shoulder ISO 8977	= 6
with shoulder ISO 8977	= 7

Shape cutting length: l	Order No
2	= 1
3	= 2
4	= 3
5	= 4
6	= 5
8	= 6
10	= 7
12	= 8
special	= X

Format: Slot length P = 13.5 mm

Format: Slot width W = 6.5 mm

Length: l ₁	Order Code character
13	= A
16	= B
20	= C
22	= D
25	= E
28	= F
30	= G
32	= H
35	= J
40	= K
special	= X

Diameter: d ₂	Order No
5	= 1
6	= 2
8	= 3
10	= 4
13	= 5
16	= 6
20	= 7
22	= 8
25	= 9
32	= 10
38	= 11
40	= 12
45	= 13
50	= 14
56	= 15
63	= 16
71	= 17
76	= 18
85	= 19
90	= 20
100	= 21

Angle:	Order Code character
0°	= A
90°	= B
180°	= C
270°	= D
special	= X

Anti-rotation element:	Order No
Pin ø3	= 1
Pin ø4	= 2
Pin ø6	= 3
polished Surface (continuous)	= 4
polished Surface top, 14 mm	= 5
polished Surface bottom, 14 mm	= 6
special	= X

Ordering Code (example):

2 6 4 6 . 1 0 F 6 . 1 3 5 0 . 0 6 5 0 . A 2

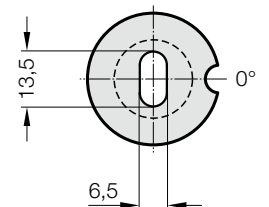
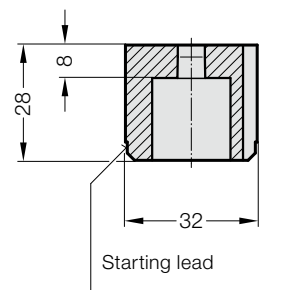
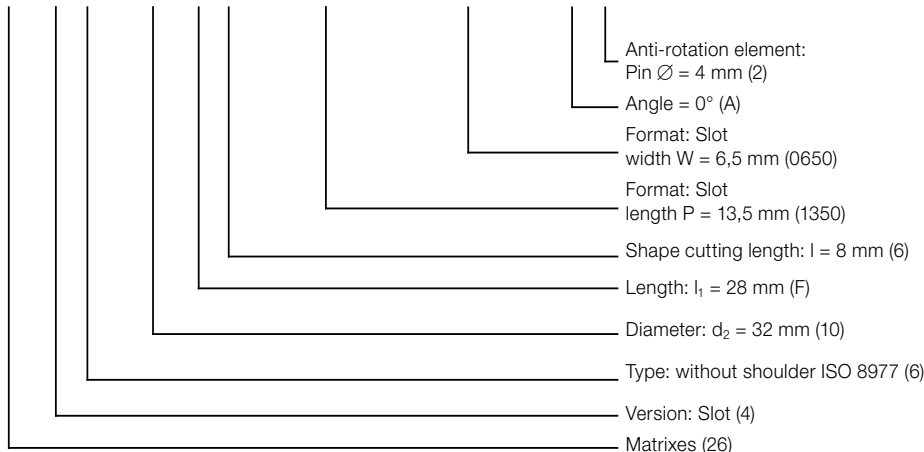

MATRIX WITHOUT SHOULDER, BLANK, ISO 8977

2606.

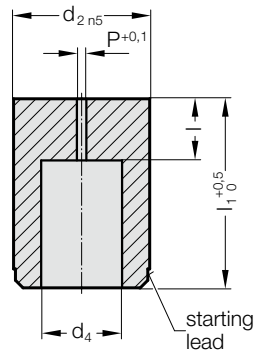

2606. Matrix without shoulder, blank, ISO 8977

d ₂ / Order No	d ₄	P	I / Order No	I ₁ / (Order Code character)	16 (B)	20 (C)	22 (D)	25 (E)	28 (F)	30 (G)	32 (H)	35 (J)	40 (K)
5 / (1)	2.8	0.8	2 (1)		●	●	●	●	●	●	●	●	
6 / (2)	3.5	1	3 (2)		●	●	●	●	●	●	●	●	
8 / (3)	4	1	4 (3)		●	●	●	●	●	●	●	●	●
10 / (4)	5.8	1	4 (3) 8 (6)		●	●	●	●	●	●	●	●	●
13 / (5)	8	1.2	5 (4) 8 (6)			●	●	●	●	●	●	●	●
16 / (6)	9.5	1.2	5 (4) 8 (6)			●	●	●	●	●	●	●	●
20 / (7)	12	1.5	8 (6) 12 (8)			●	●	●	●	●	●	●	●
22 / (8)	15	1.5	8 (6) 12 (8)			●	●	●	●	●	●	●	●
25 / (9)	17.3	1.5	8 (6) 12 (8)			●	●	●	●	●	●	●	●
32 / (10)	20.7	1.5	8 (6) 12 (8)			●	●	●	●	●	●	●	●
38 / (11)	27.7	1.5	8 (6) 12 (8)					●	●	●	●	●	●
40 / (12)	27.7	1.5	8 (6) 12 (8)					●	●	●	●	●	●
50 / (14)	37	1.5	8 (6) 12 (8)					●	●	●	●	●	●

Ordering Code (example):

2606.10F8

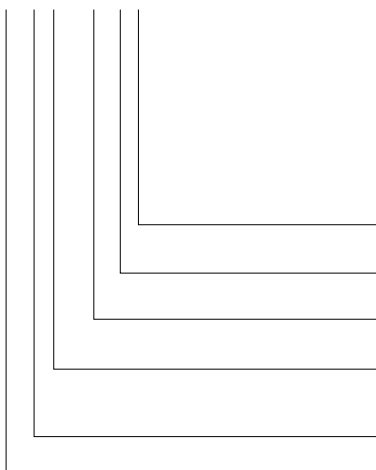

Shape cutting length: I

12 mm

Length: I₁

28 mm

Diameter: d₂

32 mm

Type:

without shoulder

ISO 8977

Execution:

blank (pilot hole bore)

Matrix

Order No

= (8)

Order Code character

= (F)

Order No

= (10)

Order No

= (6)

Order No

= (0)

= 26

Material:

HSS

Hardness 62 ± 2 HRC

Execution:

Diameter d₂, starting lead and face surfaces ground.

Diameter P is a bored pilot hole for wire EDM.
Special dimensions on request.

MATRIX WITHOUT SHOULDER, ROUND, ISO 8977



2616.

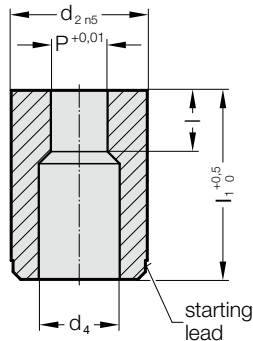

2616. Matrix without shoulder, round, ISO 8977

d ₂ / Order No	d ₄	P	l / Order No	l ₁ / (Order Code character)	16 (B)	20 (C)	22 (D)	25 (E)	28 (F)	30 (G)	32 (H)	35 (J)	40 (K)
5 / (1)	2.8	1 - 2,4	2 (1)		●	●	●	●	●	●	●	●	
6 / (2)	3.5	1,6 - 3	3 (2)		●	●	●	●	●	●	●	●	
8 / (3)	4	2 - 3,5	4 (3)		●	●	●	●	●	●	●	●	
10 / (4)	5.8	2,5 - 5	4 (3) 8 (6)		●	●	●	●	●	●	●	●	
13 / (5)	8	4 - 7	5 (4) 8 (6)			●	●	●	●	●	●	●	
16 / (6)	9.5	6 - 9	5 (4) 8 (6)			●	●	●	●	●	●	●	
20 / (7)	12	8 - 11	8 (6) 12 (8)			●	●	●	●	●	●	●	
22 / (8)	15	9 - 14	8 (6) 12 (8)			●	●	●	●	●	●	●	
25 / (9)	17.3	10,7 - 16	8 (6) 12 (8)			●	●	●	●	●	●	●	
32 / (10)	20.7	15 - 20	8 (6) 12 (8)			●	●	●	●	●	●	●	
38 / (11)	27.7	19 - 27	8 (6) 12 (8)					●	●	●	●	●	
40 / (12)	27.7	19 - 27	8 (6) 12 (8)					●	●	●	●	●	
50 / (14)	37	26 - 36	8 (6) 12 (8)					●	●	●	●	●	●

Material:

HSS
Hardness 62 ± 2 HRC

Execution:

Diameter d₂, starting lead and face surfaces ground.
Special dimensions on request.

Ordering Code (example): without anti-rotation element

2616.10F8.1510

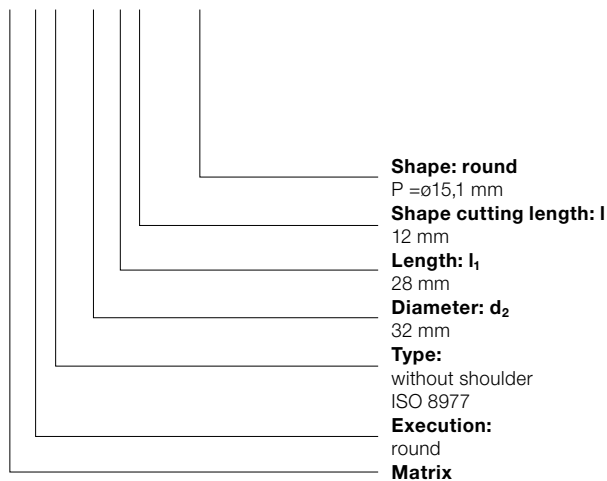

= 1510
Order No
 = (8)
Order Code character
 = (F)
Order No
 = (10)
Order No
 = (6)
Order No
 = (1)
 = 26

MATRIXES WITHOUT SHOULDER, CYLINDRICAL, ISO 8977, ANTI-ROTATION ELEMENTS

Anti-rotation element 1 (1)

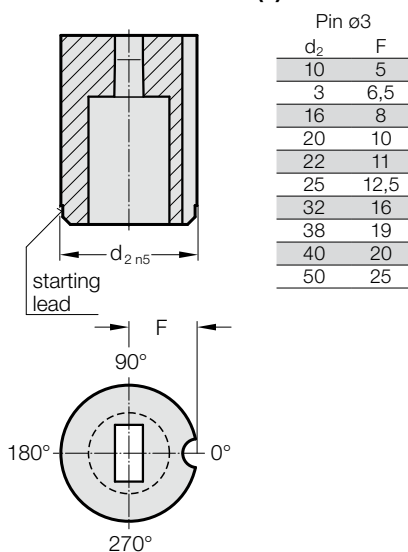

Anti-rotation element 2 (2)

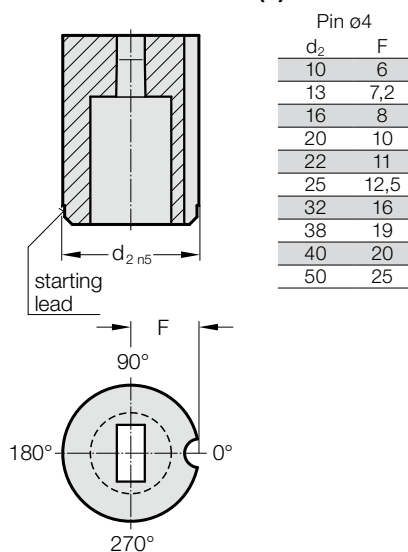

Anti-rotation element 3 (3)

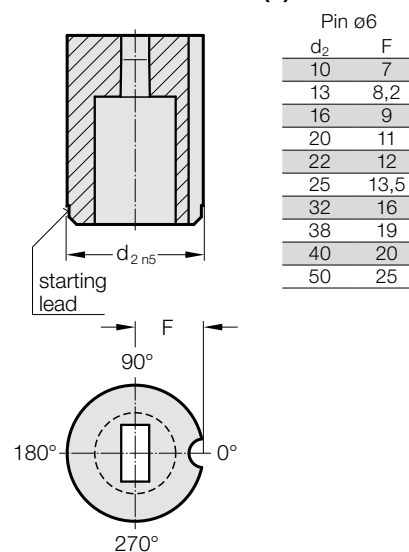

Anti-rotation element 4 (4)

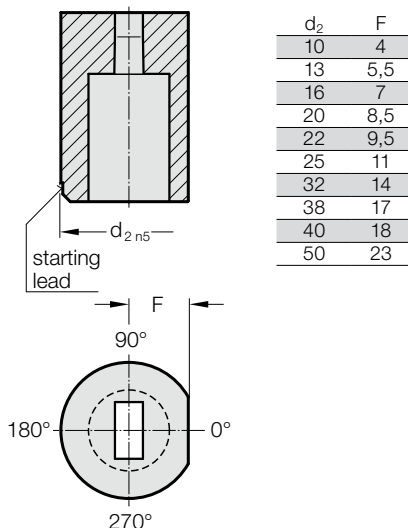

Anti-rotation element 5 (5)

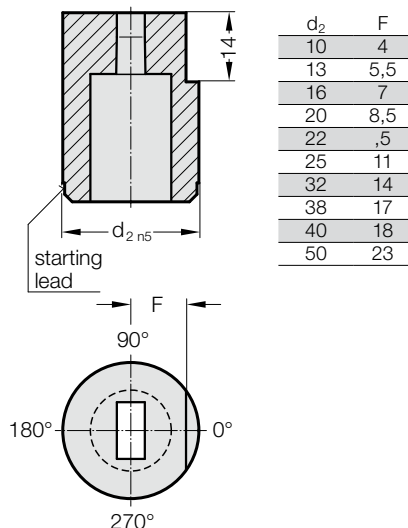

Anti-rotation element 6 (6)

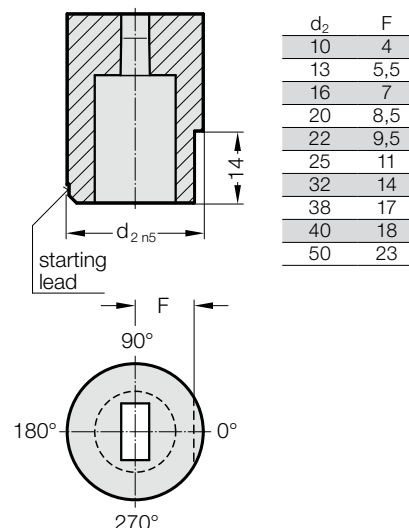

Ordering Code (example): with anti-rotation element from $d_2 \geq 10$ mm

2616.10F8.1510.A4

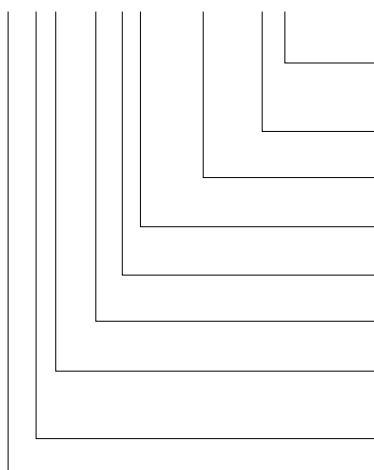

Anti-rotation element:

Polished surface
(continuous)

Angle:
0°

Shape: round
P = \varnothing 15,1 mm

Shape cutting length: l
12 mm

Length: l₁
28 mm

Diameter: d₂
32 mm

Type:
without shoulder
ISO 8977

Execution:
round

Matrix

Order No
= (4)

Order Code character
= (A)

= 1510

Order No
= (8)

Order Code character
= (F)

Order No
= (10)

Order No

= (6)

Order No

= (1)

= 26

MATRIX WITHOUT SHOULDER, SQUARE, ISO 8977



2626.

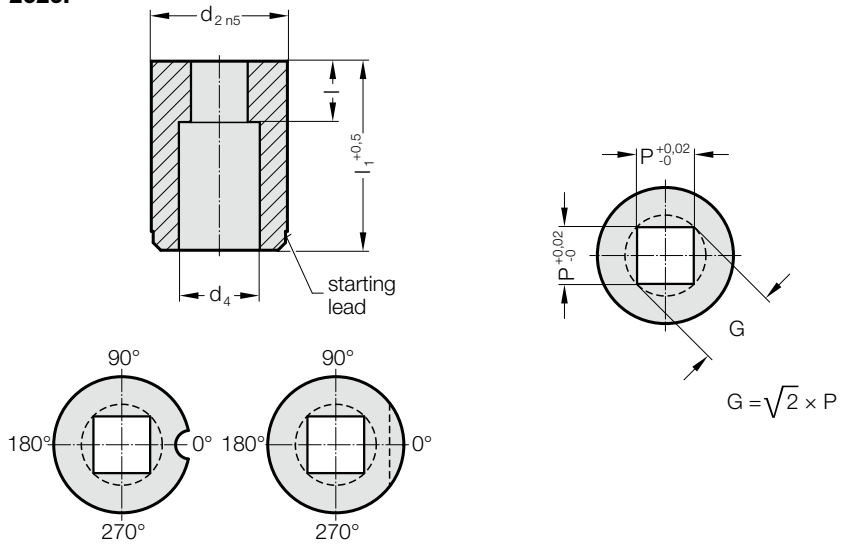

2626. Matrix without shoulder, square, ISO 8977

d ₂ / Order No	d ₄	P _{min}	G _{max}	I / Order No	l ₁ / (Order Code character)	16 (B)	20 (C)	22 (D)	25 (E)	28 (F)	30 (G)	32 (H)	35 (J)	40 (K)
10 / (4)	5.8	1.2	5	4 (3) 8 (6)		●	●	●	●	●	●	●	●	●
13 / (5)	8	2	7	5 (4) 8 (6)			●	●	●	●	●	●	●	●
16 / (6)	9.5	2.4	9	5 (4) 8 (6)			●	●	●	●	●	●	●	●
20 / (7)	12	3.2	11	8 (6) 12 (8)			●	●	●	●	●	●	●	●
22 / (8)	15	4	14	8 (6) 12 (8)			●	●	●	●	●	●	●	●
25 / (9)	17.3	4.8	16	8 (6) 12 (8)			●	●	●	●	●	●	●	●
32 / (10)	20.7	5.5	20	8 (6) 12 (8)			●	●	●	●	●	●	●	●
38 / (11)	27.7	6.4	27	8 (6) 12 (8)					●	●	●	●	●	●
40 / (12)	27.7	6.4	27	8 (6) 12 (8)					●	●	●	●	●	●
50 / (14)	37	9	36	8 (6) 12 (8)					●	●	●	●	●	●

Material:

HSS
Hardness 62 ± 2 HRC

Execution:

Diameter d₂, starting lead and face surfaces ground.
Special dimensions on request.

Note:

With kerf ≤ 0.04 mm, FIBRO rounds off sharp edges if the punch and piercing die bush are ordered together. This reduces the fitting time and the risk of an edge break during operation.

Ordering Code (example): with anti-rotation element

2626.10F8.1350.A3

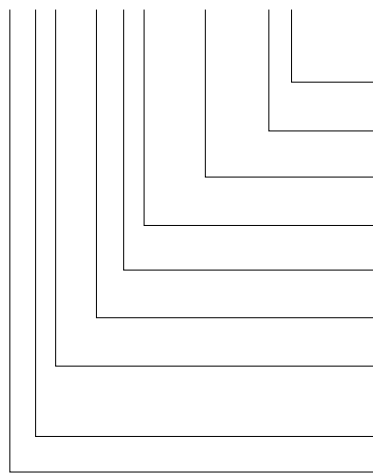

Anti-rotation element:

Pin Ø 6 mm

Angle:

0°

Shape: square, Length P

P = 13,5 mm

Shape cutting length: l

12 mm

Length: l₁

28 mm

Diameter: d₂

32 mm

Type:

without shoulder
ISO 8977

Execution:

square

Matrix

Order No

= (3)

Order Code character

= (A)

= 1350

Order No

= (8)

Order Code character

= (F)

Order No

= (10)

Order No

= (6)

Order No

= (2)

= 26

MATRIXES WITHOUT SHOULDER, CYLINDRICAL, ISO 8977, ANTI-ROTATION ELEMENTS

Anti-rotation element 1 (1)

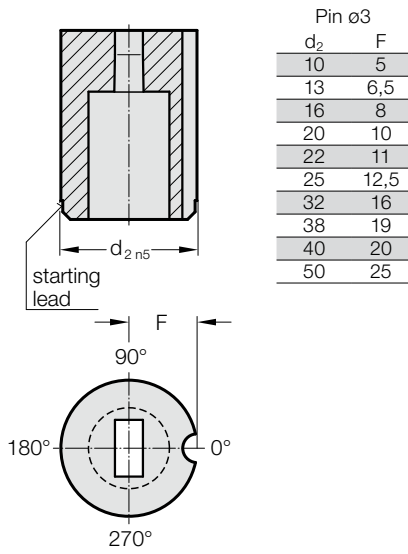

Anti-rotation element 2 (2)

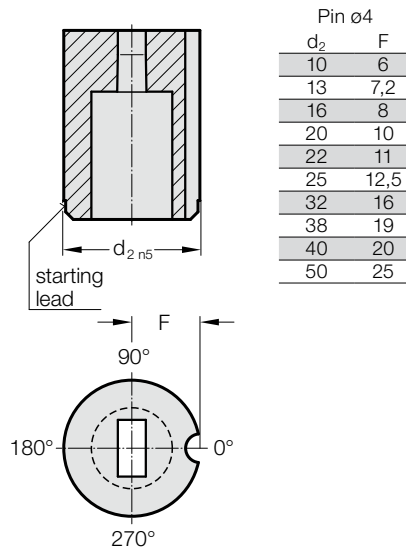

Anti-rotation element 3 (3)

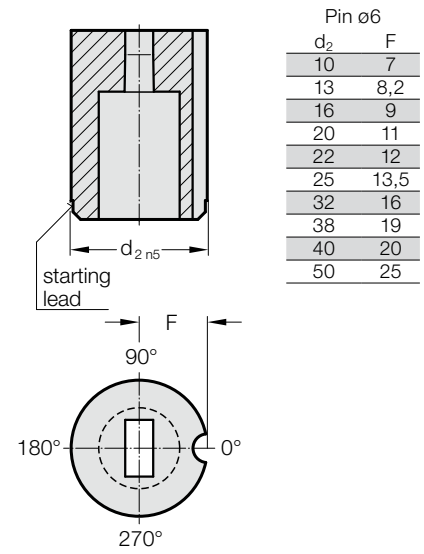

Anti-rotation element 4 (4)

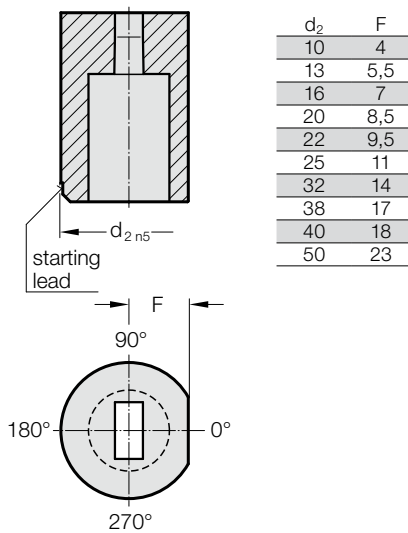

Anti-rotation element 5 (5)

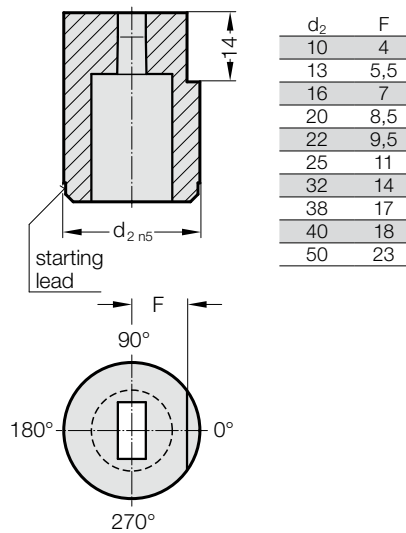

Anti-rotation element 6 (6)

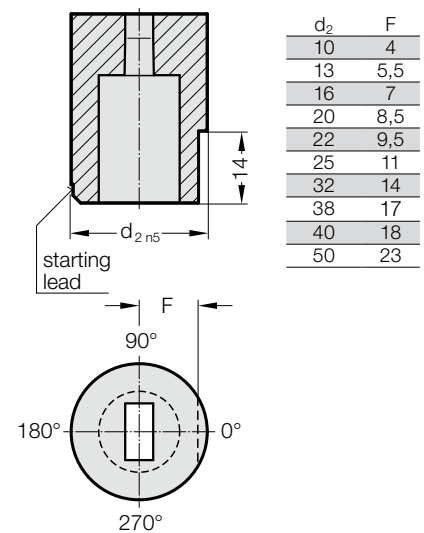

MATRIX WITHOUT SHOULDER, RECTANGULAR, ISO 8977



2636.

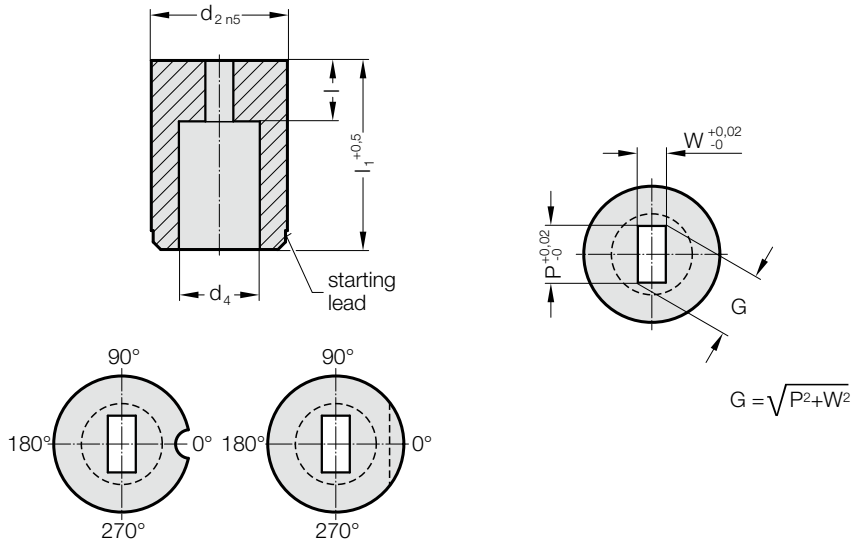

2636. Matrix without shoulder, rectangular, ISO 8977

d ₂ / Order No	d ₄	W _{min}	G _{max}	l / Order No	l ₁ / (Order Code character)	16 (B)	20 (C)	22 (D)	25 (E)	28 (F)	30 (G)	32 (H)	35 (J)	40 (K)
10 / (4)	5.8	1.2	5	4 (3) 8 (6)		●	●	●	●	●	●	●	●	●
13 / (5)	8	2	7	5 (4) 8 (6)			●	●	●	●	●	●	●	●
16 / (6)	9.5	2.4	9	5 (4) 8 (6)			●	●	●	●	●	●	●	●
20 / (7)	12	3.2	11	8 (6) 12 (8)			●	●	●	●	●	●	●	●
22 / (8)	15	4	14	8 (6) 12 (8)			●	●	●	●	●	●	●	●
25 / (9)	17.3	4.8	16	8 (6) 12 (8)			●	●	●	●	●	●	●	●
32 / (10)	20.7	5.5	20	8 (6) 12 (8)			●	●	●	●	●	●	●	●
38 / (11)	27.7	6.4	27	8 (6) 12 (8)					●	●	●	●	●	●
40 / (12)	27.7	6.4	27	8 (6) 12 (8)					●	●	●	●	●	●
50 / (14)	37	9	36	8 (6) 12 (8)					●	●	●	●	●	●

Material:

HSS
Hardness 62 ± 2 HRC

Execution:

Diameter d₂, starting lead and face surfaces ground.
Special dimensions on request.

Note:

With kerf ≤ 0.04 mm, FIBRO rounds off sharp edges if the punch and piercing die bush are ordered together. This reduces the fitting time and the risk of an edge break during operation.

Ordering Code (example): with anti-rotation element

2636.10F8.1350.0650.B4

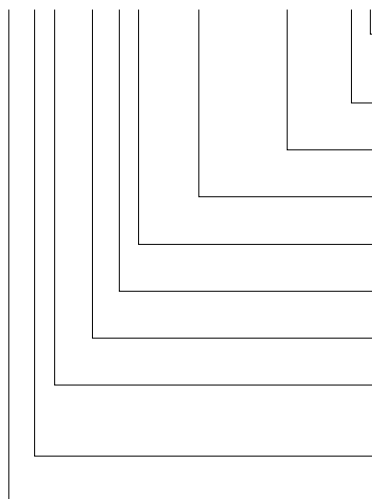

Anti-rotation element:

Polished surface
(continuous)

Angle:

90°

Shape: rectangular, Width W

W = 6,5 mm

Shape: rectangular, Length P

P = 13,5 mm

Shape cutting length: l

12 mm

Length: l₁

28 mm

Diameter: d₂

32 mm

Type:

without shoulder

ISO 8977

Execution:

rectangular

Matrix

Order No

= (4)

Order Code character

= (B)

= 0650

= 1350

Order No

= (8)

Order Code character

= (F)

Order No

= (10)

Order No

= (6)

Order No

= (3)

= 26

MATRIXES WITHOUT SHOULDER, CYLINDRICAL, ISO 8977, ANTI-ROTATION ELEMENTS

Anti-rotation element 1 (1)

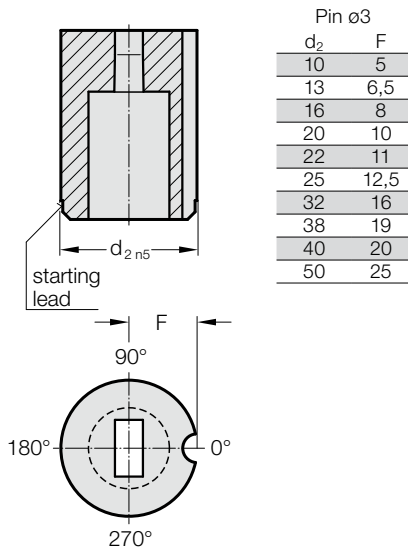

Anti-rotation element 2 (2)

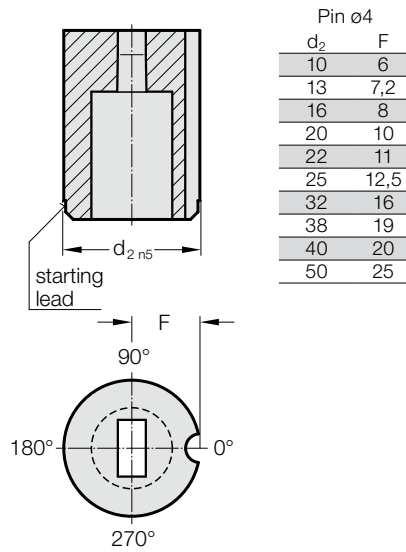

Anti-rotation element 3 (3)

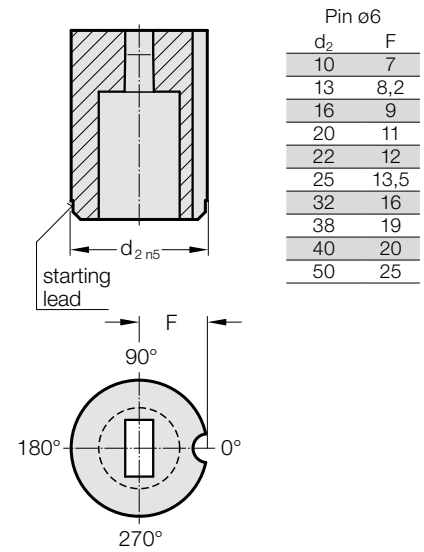

Anti-rotation element 4 (4)

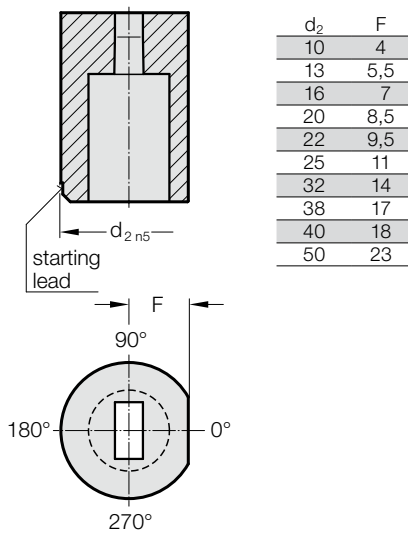

Anti-rotation element 5 (5)

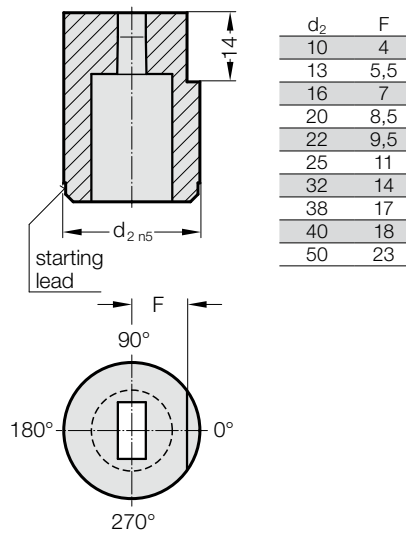

Anti-rotation element 6 (6)

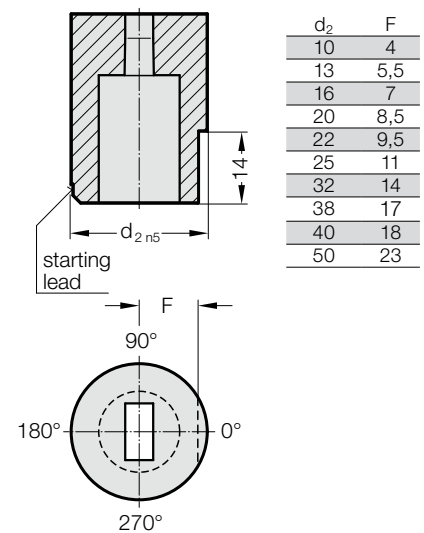

MATRIX WITHOUT SHOULDER, SLOT, ISO 8977



2646.

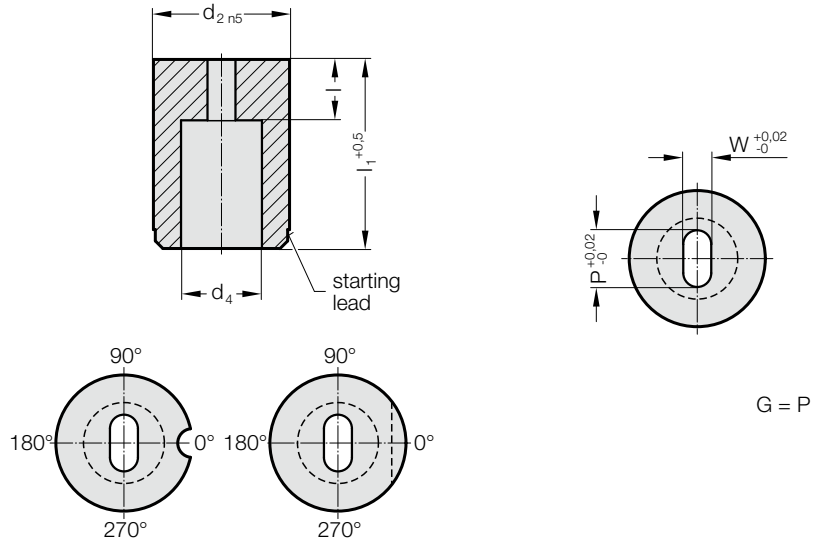

2646. Matrix without shoulder, slot, ISO 8977

d_2 / Order No	d_4	W_{min}	G_{max}	I / Order No	l_1 / (Order Code character)	16 (B)	20 (C)	22 (D)	25 (E)	28 (F)	30 (G)	32 (H)	35 (J)	40 (K)
10 / (4)	5.8	1.2	5	4 (3) 8 (6)		●	●	●	●	●	●	●	●	●
13 / (5)	8	2	7	5 (4) 8 (6)			●	●	●	●	●	●	●	●
16 / (6)	9.5	2.4	9	5 (4) 8 (6)			●	●	●	●	●	●	●	●
20 / (7)	12	3.2	11	8 (6) 12 (8)			●	●	●	●	●	●	●	●
22 / (8)	15	4	14	8 (6) 12 (8)			●	●	●	●	●	●	●	●
25 / (9)	17.3	4.8	16	8 (6) 12 (8)			●	●	●	●	●	●	●	●
32 / (10)	20.7	5.5	20	8 (6) 12 (8)			●	●	●	●	●	●	●	●
38 / (11)	27.7	6.4	27	8 (6) 12 (8)					●	●	●	●	●	●
40 / (12)	27.7	6.4	27	8 (6) 12 (8)					●	●	●	●	●	●
50 / (14)	37	9	36	8 (6) 12 (8)					●	●	●	●	●	●

Material:

HSS
Hardness 62 ± 2 HRC

Execution:

Diameter d_2 , starting lead and face surfaces ground.
Special dimensions on request.

Ordering Code (example): with anti-rotation element

2646.10F8.1350.0650.B2

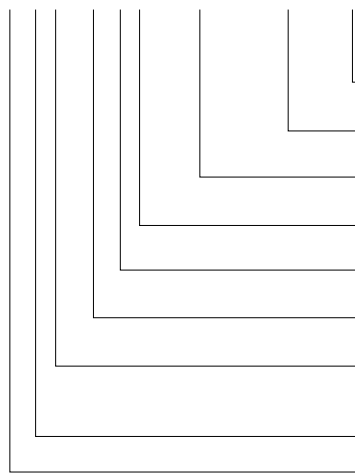

Anti-rotation element:

Pin \varnothing 4 mm

Angle:

90°

Shape: slot, Width W

W = 6,5 mm

Shape: slot, Length P

P = 13,5 mm

Shape cutting length: I

12 mm

Length: l_1

28 mm

Diameter: d_2

32 mm

Type:

without shoulder

ISO 8977

Execution:

slot

Matrix

Order No

= (2)

Order Code character

= (B)

= 0650

= 1350

Order No

= (8)

Order Code character

= (F)

Order No

= (10)

Order No

= (6)

Order No

= (4)

= 26

MATRIXES WITHOUT SHOULDER, CYLINDRICAL, ISO 8977, ANTI-ROTATION ELEMENTS

Anti-rotation element 1 (1)

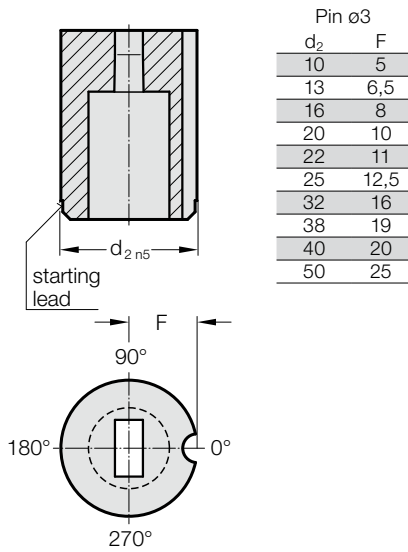

Anti-rotation element 2 (2)

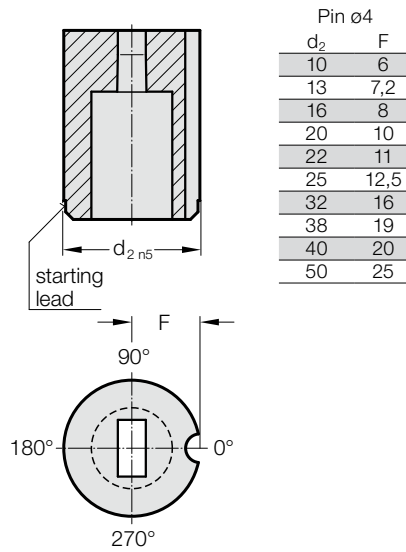

Anti-rotation element 3 (3)

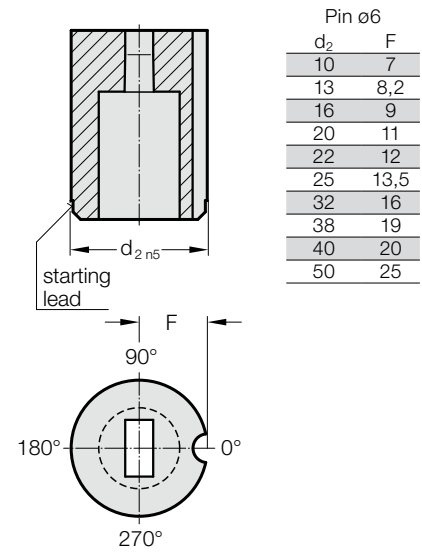

Anti-rotation element 4 (4)

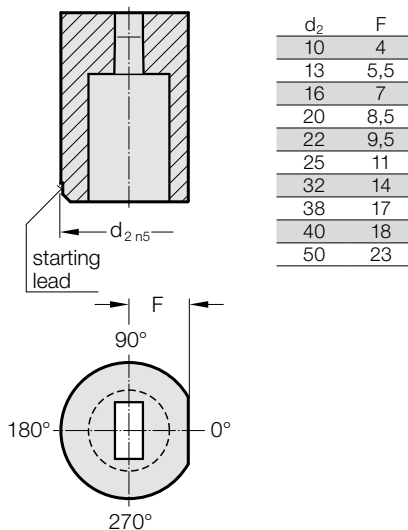

Anti-rotation element 5 (5)

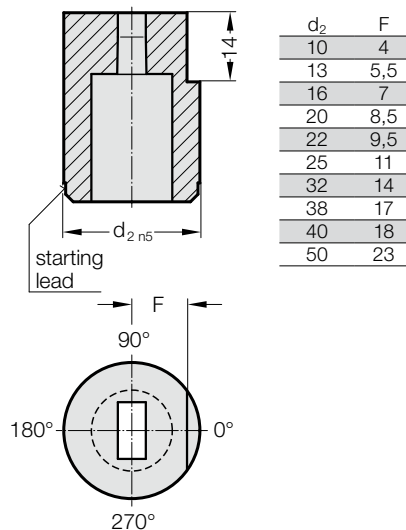

Anti-rotation element 6 (6)

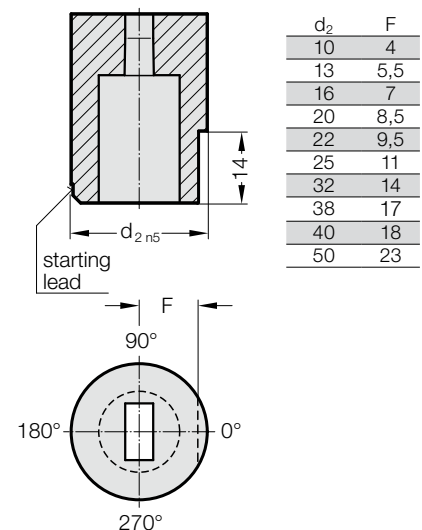

MATRIX WITHOUT SHOULDER, RECTANGLE WITH RADIUSSED CORNERS, ISO 8977

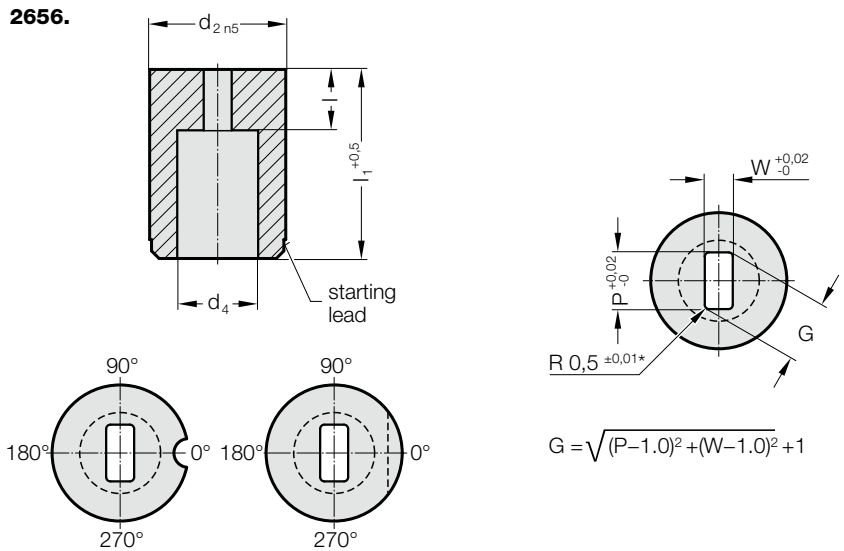

2656. Matrix without shoulder, rectangle with radiused corners, ISO 8977

d_2 / Order No	d_4	W_{min}	G_{max}	l / Order No	l_1 / (Order Code character)	16 (B)	20 (C)	22 (D)	25 (E)	28 (F)	30 (G)	32 (H)	35 (J)	40 (K)
10 / (4)	5.8	1.2	5	4 (3) 8 (6)		●	●	●	●	●	●	●	●	
13 / (5)	8	2	7	5 (4) 8 (6)			●	●	●	●	●	●	●	
16 / (6)	9.5	2.4	9	5 (4) 8 (6)			●	●	●	●	●	●	●	
20 / (7)	12	3.2	11	8 (6) 12 (8)			●	●	●	●	●	●	●	
22 / (8)	15	4	14	8 (6) 12 (8)			●	●	●	●	●	●	●	
25 / (9)	17.3	4.8	16	8 (6) 12 (8)			●	●	●	●	●	●	●	
32 / (10)	20.7	5.5	20	8 (6) 12 (8)			●	●	●	●	●	●	●	
38 / (11)	27.7	6.4	27	8 (6) 12 (8)					●	●	●	●	●	
40 / (12)	27.7	6.4	27	8 (6) 12 (8)					●	●	●	●	●	
50 / (14)	37	9	36	8 (6) 12 (8)					●	●	●	●	●	●

Material:

HSS
Hardness 62 ± 2 HRC

Execution:

Diameter d_2 , starting lead and face surfaces ground.

Special dimensions on request.

* For other radius options, see standardised special shapes.

Ordering Code (example): with anti-rotation element

2656.10F8.1350.0650.A1

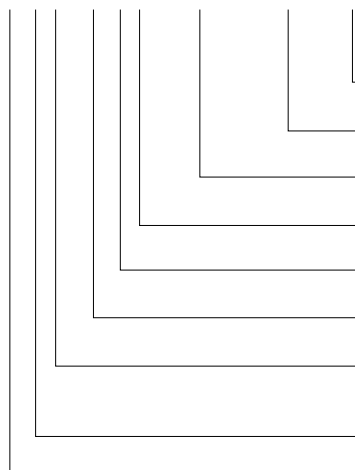

Anti-rotation element:

Pin $\varnothing 3$ mm

Angle:

0°

Shape: rectangle with radiused corners, Width W

$W = 6,5$ mm

Shape: rectangle with radiused corners, Length P

$P = 13,5$ mm

Shape cutting length: l

12 mm

Length: l_1

28 mm

Diameter: d_2

32 mm

Type:

without shoulder

ISO 8977

Execution:

rectangle with radiused corners

Matrix

Order No

= (1)

Order Code character

= (A)

Order Code character

= 0650

Order Code character

= 1350

Order No

= (8)

Order Code character

= (F)

Order No

= (10)

Order No

= (6)

Order No

= (5)

Order No

= 26

MATRIXES WITHOUT SHOULDER, CYLINDRICAL, ISO 8977, ANTI-ROTATION ELEMENTS

Anti-rotation element 1 (1)

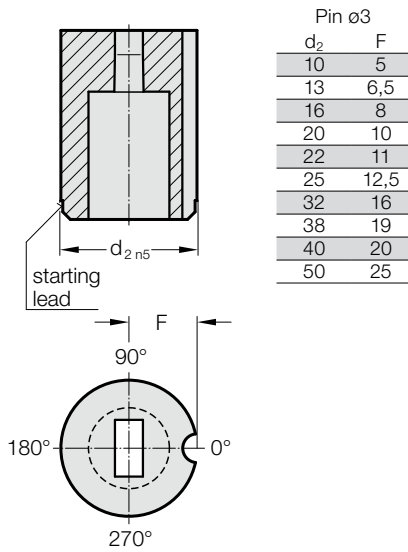

Anti-rotation element 2 (2)

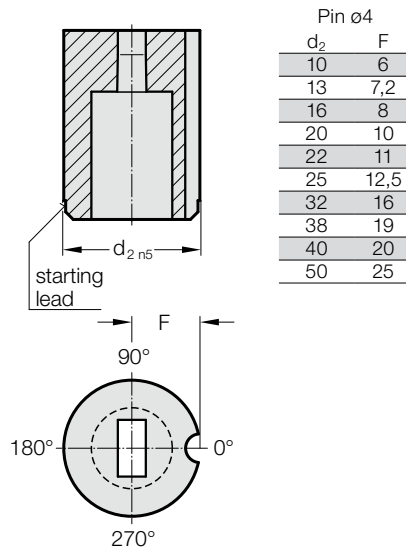

Anti-rotation element 3 (3)

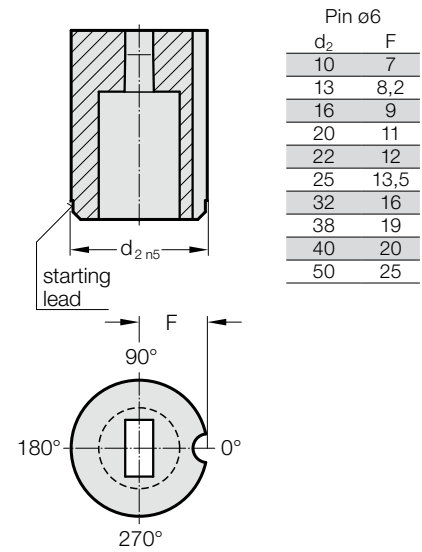

Anti-rotation element 4 (4)

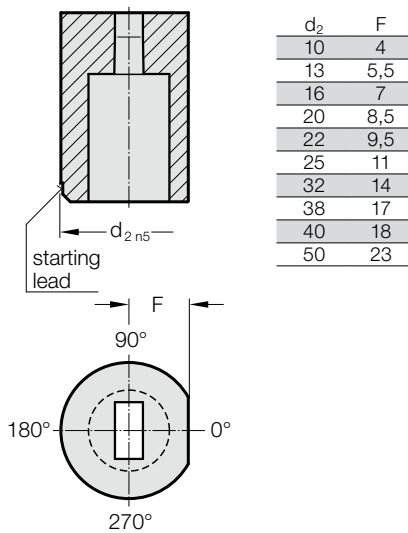

Anti-rotation element 5 (5)

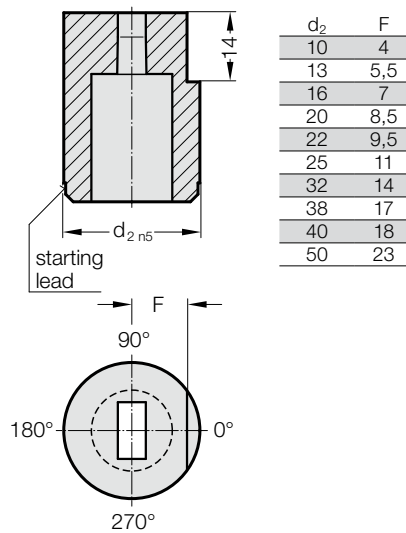

Anti-rotation element 6 (6)

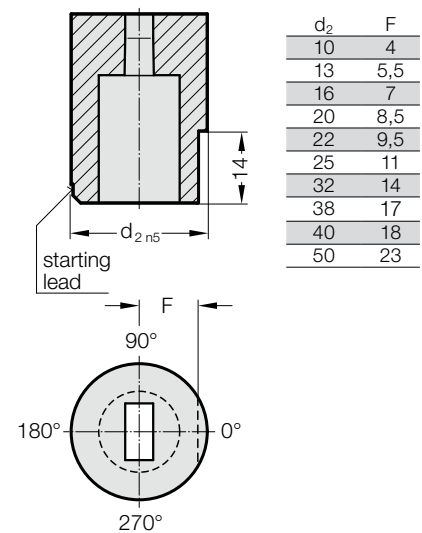

MATRIX WITH SHOULDER, BLANK, ISO 8977

2607.

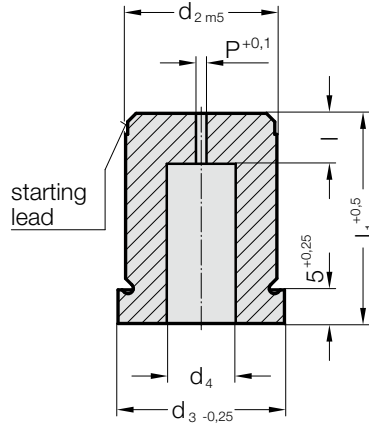

2607. Matrix with shoulder, blank, ISO 8977

d ₂ / Order No	d ₃	d ₄	P	I / Order No	I ₁ / (Order Code character)	16 (B)	20 (C)	22 (D)	25 (E)	28 (F)	30 (G)	32 (H)	35 (J)
5 / (1)	8	2.8	0.8	2 (1)		●	●	●	●	●	●	●	●
6 / (2)	9	3.5	1	3 (2)		●	●	●	●	●	●	●	●
8 / (3)	11	4	1	4 (3)		●	●	●	●	●	●	●	●
10 / (4)	13	5.8	1	4 (3) 8 (6)		●	●	●	●	●	●	●	●
13 / (5)	16	8	1.2	5 (4) 8 (6)			●	●	●	●	●	●	●
16 / (6)	19	9.5	1.2	5 (4) 8 (6)			●	●	●	●	●	●	●
20 / (7)	23	12	1.5	8 (6) 12 (8)			●	●	●	●	●	●	●
22 / (8)	25	15	1.5	8 (6) 12 (8)			●	●	●	●	●	●	●
25 / (9)	28	17.3	1.5	8 (6) 12 (8)			●	●	●	●	●	●	●
32 / (10)	35	20.7	1.5	8 (6) 12 (8)			●	●	●	●	●	●	●
38 / (11)	41	27.7	1.5	8 (6) 12 (8)			●	●	●	●	●	●	●
40 / (12)	43	27.7	1.5	8 (6) 12 (8)			●	●	●	●	●	●	●
50 / (14)	53	37	1.5	8 (6) 12 (8)			●	●	●	●	●	●	●

Ordering Code (example):

2607.11E6

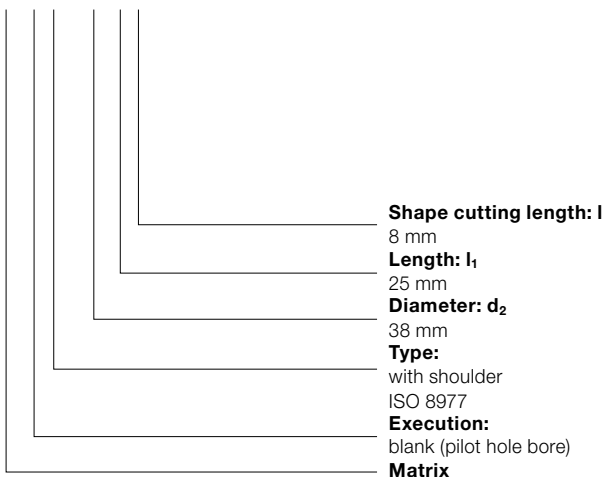

Order No
 = (6)
Order Code character
 = (E)
Order No
 = (11)
Order No
 = (7)
Order No
 = (0)
 = 26

Material:

HSS
 Hardness 62 ± 2 HRC

Execution:

Diameter d₂, starting lead and face surfaces ground.
 Diameter P is a bored pilot hole for wire EDM.
 Special dimensions on request.

MATRIX WITH SHOULDER, ROUND, ISO 8977



2617.

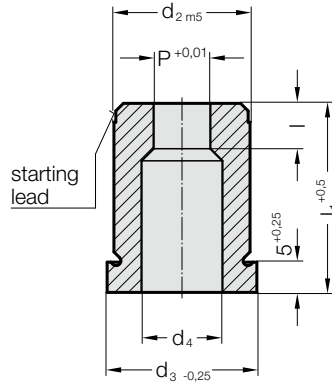

2617. Matrix with shoulder, round, ISO 8977

d ₂ / Order No	d ₃	d ₄	P	l / Order No	l ₁ / (Order Code character)	16 (B)	20 (C)	22 (D)	25 (E)	28 (F)	30 (G)	32 (H)	35 (J)
5 / (1)	8	2.8	1 - 2,4	2 (1)		●	●	●	●	●	●	●	●
6 / (2)	9	3.5	1,6 - 3	3 (2)		●	●	●	●	●	●	●	●
8 / (3)	11	4	2 - 3,5	4 (3)		●	●	●	●	●	●	●	●
10 / (4)	13	5.8	2,5 - 5	4 (3) 8 (6)		●	●	●	●	●	●	●	●
13 / (5)	16	8	4 - 7	5 (4) 8 (6)			●	●	●	●	●	●	●
16 / (6)	19	9.5	6 - 9	5 (4) 8 (6)			●	●	●	●	●	●	●
20 / (7)	23	12	8 - 11	8 (6) 12 (8)			●	●	●	●	●	●	●
22 / (8)	25	15	9 - 14	8 (6) 12 (8)			●	●	●	●	●	●	●
25 / (9)	28	17.3	10,7 - 16	8 (6) 12 (8)			●	●	●	●	●	●	●
32 / (10)	35	20.7	15 - 20	8 (6) 12 (8)			●	●	●	●	●	●	●
38 / (11)	41	27.7	19 - 27	8 (6) 12 (8)			●	●	●	●	●	●	●
40 / (12)	43	27.7	19 - 27	8 (6) 12 (8)			●	●	●	●	●	●	●
50 / (14)	53	37	26 - 36	8 (6) 12 (8)			●	●	●	●	●	●	●

Material:

HSS
Hardness 62 ± 2 HRC

Execution:

Diameter d₂, starting lead and face surfaces ground.
Special dimensions on request.

Ordering Code (example): without anti-rotation element

2617.10F8.1510

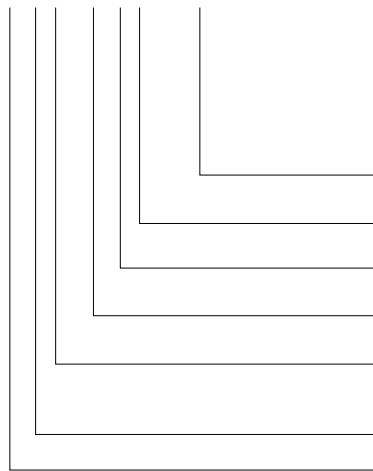

Shape: round
P = ø15,1 mm
Shape cutting length: l
12 mm
Length: l₁
28 mm
Diameter: d₂
32 mm
Type:
with shoulder
ISO 8977
Execution:
round
Matrix

= 1510
Order No
= (8)
Order Code character
= (F)
Order No
= (10)
Order No
= (7)
Order No
= (1)
= 26

MATRIXES WITH SHOULDER, CYLINDRICAL, ISO 8977, ANTI-ROTATION ELEMENTS

Anti-rotation element 1 (1)

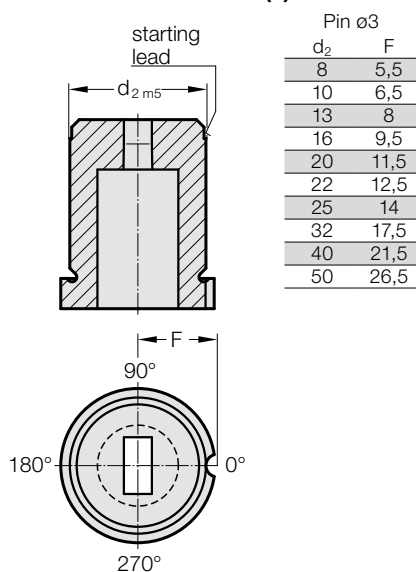

Anti-rotation element 2 (2)

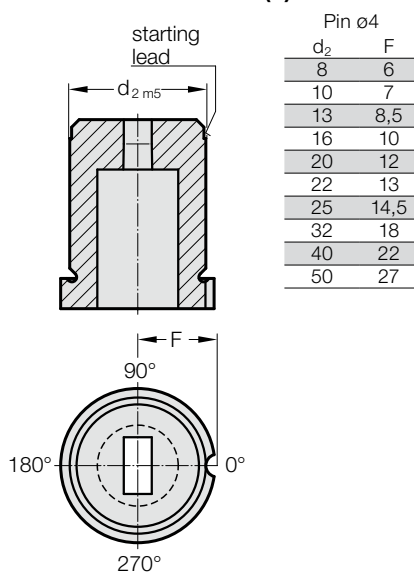

Anti-rotation element 3 (3)

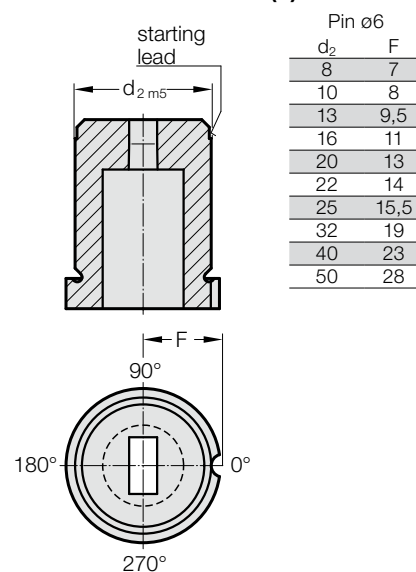

Anti-rotation element 4 (4)

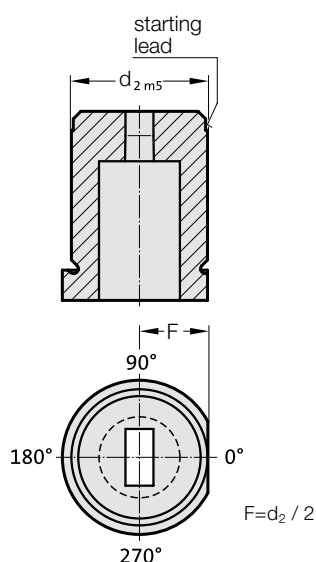

Ordering Code (example): with anti-rotation element from $d_2 \geq 8$ mm

2617.10F8.1510.A4

	Anti-rotation element: Polished surface (continuous)	Order No = (4)
	Angle: 0°	Order Code character = (A)
	Shape: round P = $\varnothing 15,1$ mm	= 1510
	Shape cutting length: l 12 mm	Order No = (8)
	Length: l₁ 28 mm	Order Code character = (F)
	Diameter: d₂ 32 mm	Order No = (10)
	Type: with shoulder ISO 8977	Order No = (7)
	Execution: round	Order No = (1)
	Matrix	= 26

MATRIX WITH SHOULDER, SQUARE, ISO 8977



2627.

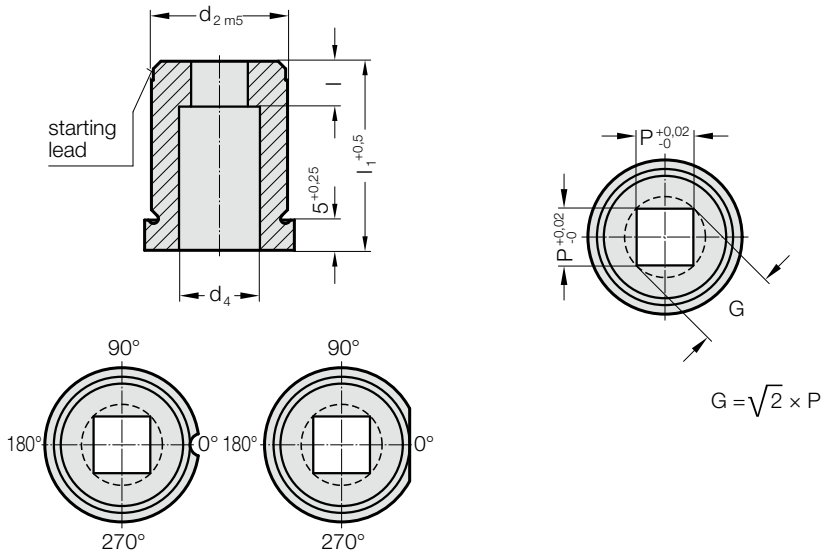

2627. Matrix with shoulder, square, ISO 8977

d ₂ / Order No	d ₃	d ₄	P _{min}	G _{max}	I / Order No	l ₁ / (Order Code character)	16 (B)	20 (C)	22 (D)	25 (E)	28 (F)	30 (G)	32 (H)	35 (J)
8 / (3)	11	4	1.2	3.5	4 (3)		●	●	●	●	●	●	●	●
10 / (4)	13	5.8	1.2	5	4 (3) 8 (6)		●	●	●	●	●	●	●	●
13 / (5)	16	8	2	7	5 (4) 8 (6)		●	●	●	●	●	●	●	●
16 / (6)	19	9.5	2.4	9	5 (4) 8 (6)		●	●	●	●	●	●	●	●
20 / (7)	23	12	3.2	11	8 (6) 12 (8)		●	●	●	●	●	●	●	●
22 / (8)	25	15	4	14	8 (6) 12 (8)		●	●	●	●	●	●	●	●
25 / (9)	28	17.3	4.8	16	8 (6) 12 (8)		●	●	●	●	●	●	●	●
32 / (10)	35	20.7	5.5	20	8 (6) 12 (8)		●	●	●	●	●	●	●	●
38 / (11)	41	27.7	6.4	27	8 (6) 12 (8)		●	●	●	●	●	●	●	●
40 / (12)	43	27.7	6.4	27	8 (6) 12 (8)		●	●	●	●	●	●	●	●
50 / (14)	53	37	6.4	36	8 (6) 12 (8)		●	●	●	●	●	●	●	●

Material:

HSS
Hardness 62 ± 2 HRC

Execution:

Diameter d₂, starting lead and face surfaces ground.
Special dimensions on request.

Note:

With kerf ≤ 0.04 mm, FIBRO rounds off sharp edges if the punch and piercing die bush are ordered together. This reduces the fitting time and the risk of an edge break during operation.

Ordering Code (example): with anti-rotation element

2627.10F8.1350.A3

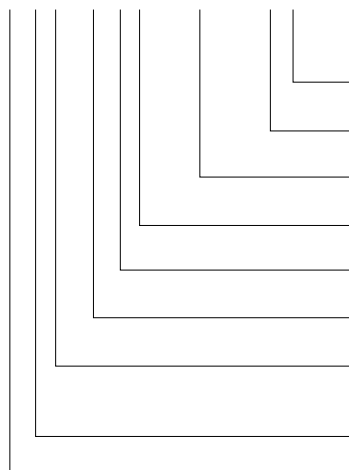

Anti-rotation element:

Pin Ø 6 mm

Angle:

0°

Shape: square, Length P

P = 13,5 mm

Shape cutting length: l

12 mm

Length: l₁

28 mm

Diameter: d₂

32 mm

Type:

with shoulder

ISO 8977

Execution:

square

Matrix

Order No

= (3)

Order Code character

= (A)

= 1350

Order No

= (8)

Order Code character

= (F)

Order No

= (10)

Order No

= (7)

Order No

= (2)

= 26

MATRIXES WITH SHOULDER, CYLINDRICAL, ISO 8977, ANTI-ROTATION ELEMENTS

Anti-rotation element 1 (1)

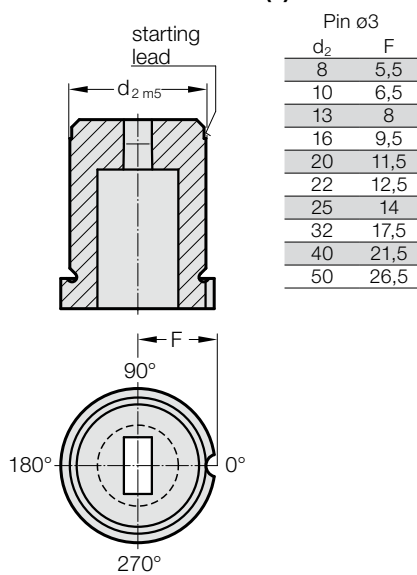

Anti-rotation element 2 (2)

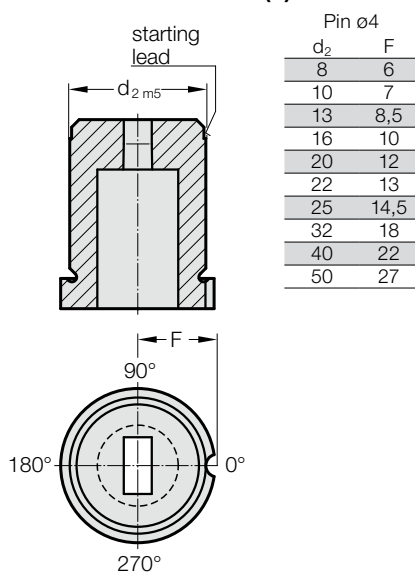

Anti-rotation element 3 (3)

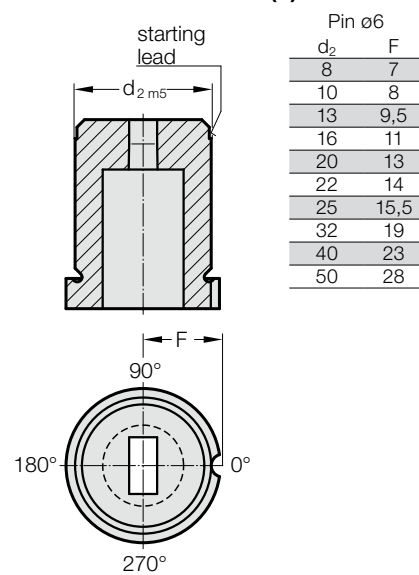

Anti-rotation element 4 (4)

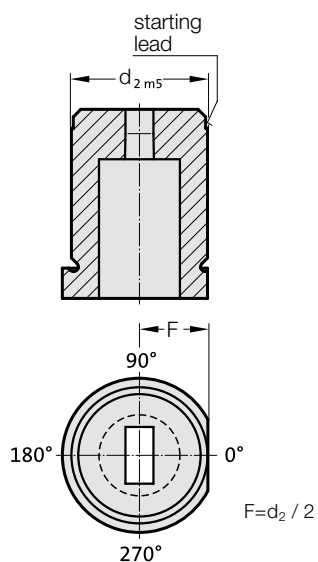

MATRIX WITH SHOULDER, RECTANGULAR, ISO 8977



2637.

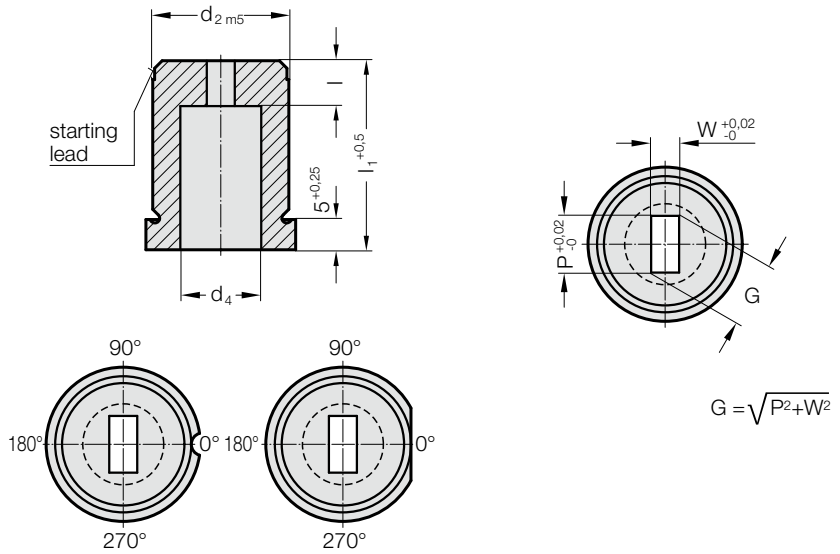

2637. Matrix with shoulder, rectangular, ISO 8977

d ₂ / Order No	d ₃	d ₄	W _{min}	G _{max}	l / Order No	l ₁ / (Order Code character)	16 (B)	20 (C)	22 (D)	25 (E)	28 (F)	30 (G)	32 (H)	35 (J)
8 / (3)	11	4	1.2	3.5	4 (3)		●	●	●	●	●	●	●	●
10 / (4)	13	5.8	1.2	5	4 (3) 8 (6)		●	●	●	●	●	●	●	●
13 / (5)	16	8	2	7	5 (4) 8 (6)		●	●	●	●	●	●	●	●
16 / (6)	19	9.5	2.4	9	5 (4) 8 (6)		●	●	●	●	●	●	●	●
20 / (7)	23	12	3.2	11	8 (6) 12 (8)		●	●	●	●	●	●	●	●
22 / (8)	25	15	4	14	8 (6) 12 (8)		●	●	●	●	●	●	●	●
25 / (9)	28	17.3	4.8	16	8 (6) 12 (8)		●	●	●	●	●	●	●	●
32 / (10)	35	20.7	5.5	20	8 (6) 12 (8)		●	●	●	●	●	●	●	●
38 / (11)	41	27.7	6.4	27	8 (6) 12 (8)		●	●	●	●	●	●	●	●
40 / (12)	43	27.7	6.4	27	8 (6) 12 (8)		●	●	●	●	●	●	●	●
50 / (14)	53	37	6.4	36	8 (6) 12 (8)		●	●	●	●	●	●	●	●

Material:

HSS
Hardness 62 ± 2 HRC

Execution:

Diameter d₂, starting lead and face surfaces ground.
Special dimensions on request.

Note:

With kerf ≤ 0.04 mm, FIBRO rounds off sharp edges if the punch and piercing die bush are ordered together. This reduces the fitting time and the risk of an edge break during operation.

Ordering Code (example): with anti-rotation element

2637.10F8.1350.0650.B2

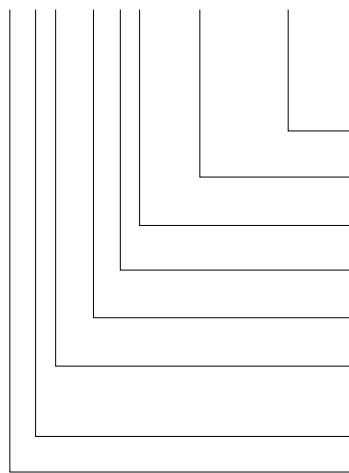

Anti-rotation element:

Pin Ø 4 mm

Angle:

90°

Shape: rectangular, Width W

W = 6,5 mm

Shape: rectangular, Length P

P = 13,5 mm

Shape cutting length: l

12 mm

Length: l₁

28 mm

Diameter: d₂

32 mm

Type:

with shoulder

ISO 8977

Execution:

rectangular

Matrix

Order No

= (2)

Order Code character

= (B)

= 0650

= 1350

Order No

= (8)

Order Code character

= (F)

Order No

= (10)

Order No

= (7)

Order No

= (3)

= 26

MATRIXES WITH SHOULDER, CYLINDRICAL, ISO 8977, ANTI-ROTATION ELEMENTS

Anti-rotation element 1 (1)

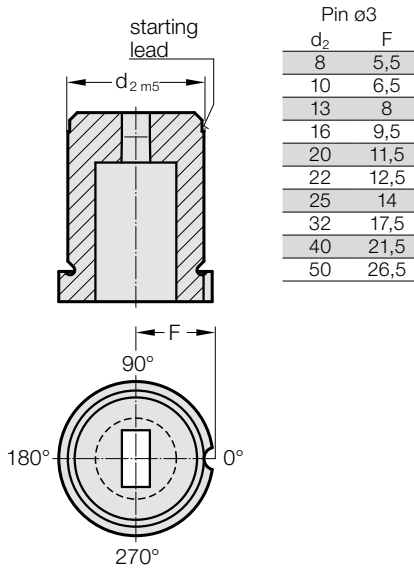

Anti-rotation element 2 (2)

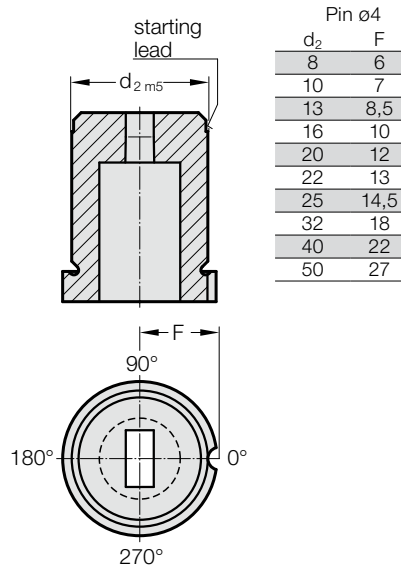

Anti-rotation element 3 (3)

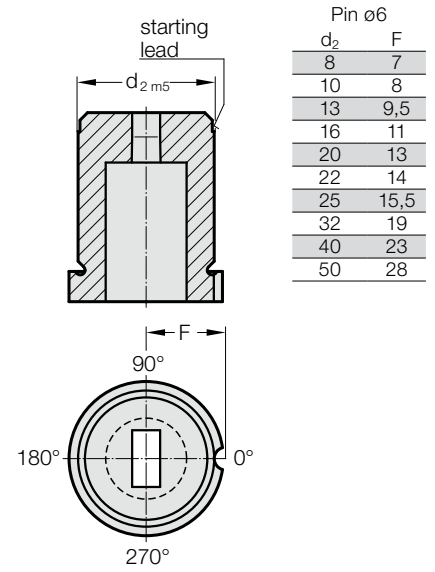

Anti-rotation element 4 (4)

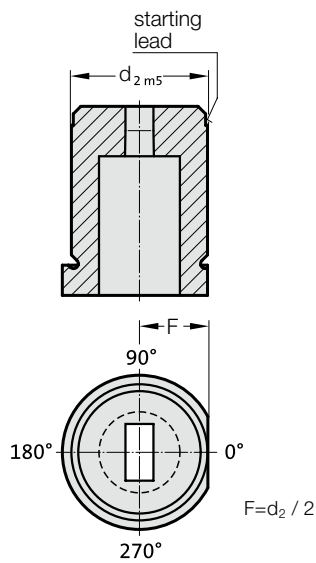

MATRIX WITH SHOULDER, SLOT, ISO 8977



2647.

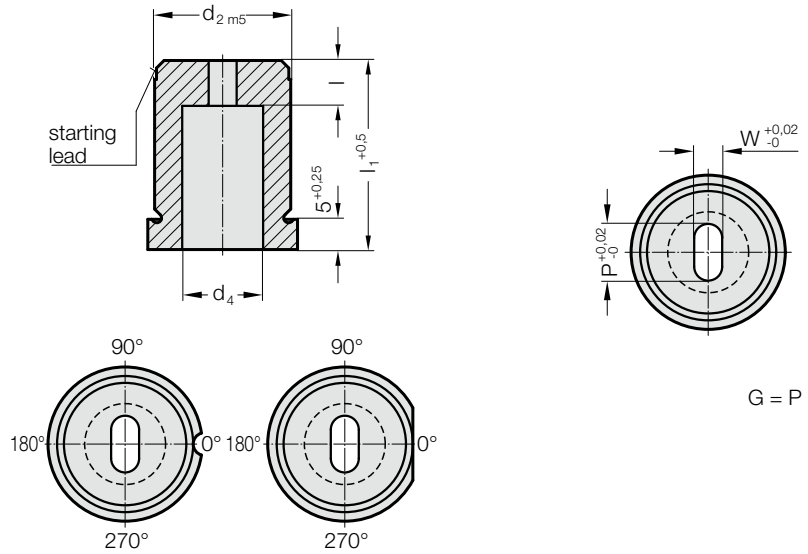

G = P

2647. Matrix with shoulder, slot, ISO 8977

d ₂ / Order No	d ₃	d ₄	W _{min}	G _{max}	l / Order No	l ₁ / (Order Code character)	16 (B)	20 (C)	22 (D)	25 (E)	28 (F)	30 (G)	32 (H)	35 (J)
8 / (3)	11	4	1.2	3.5	4 (3)		●	●	●	●	●	●	●	●
10 / (4)	13	5.8	1.2	5	4 (3) 8 (6)		●	●	●	●	●	●	●	●
13 / (5)	16	8	2	7	5 (4) 8 (6)		●	●	●	●	●	●	●	●
16 / (6)	19	9.5	2.4	9	5 (4) 8 (6)		●	●	●	●	●	●	●	●
20 / (7)	23	12	3.2	11	8 (6) 12 (8)		●	●	●	●	●	●	●	●
22 / (8)	25	15	4	14	8 (6) 12 (8)		●	●	●	●	●	●	●	●
25 / (9)	28	17.3	4.8	16	8 (6) 12 (8)		●	●	●	●	●	●	●	●
32 / (10)	35	20.7	5.5	20	8 (6) 12 (8)		●	●	●	●	●	●	●	●
38 / (11)	41	27.7	6.4	27	8 (6) 12 (8)		●	●	●	●	●	●	●	●
40 / (12)	43	27.7	6.4	27	8 (6) 12 (8)		●	●	●	●	●	●	●	●
50 / (14)	53	37	6.4	36	8 (6) 12 (8)		●	●	●	●	●	●	●	●

Material:

HSS
Hardness 62 ± 2 HRC

Execution:

Diameter d₂, starting lead and face surfaces ground.
Special dimensions on request.

Ordering Code (example): with anti-rotation element

2647.10F8.1350.0650.A3

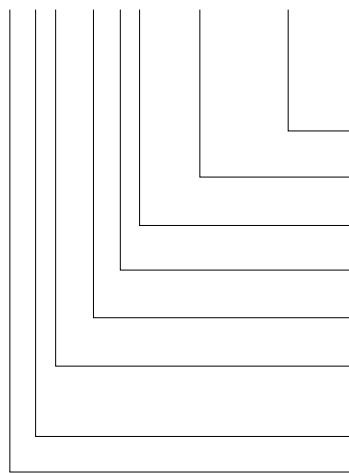

Anti-rotation element:

Pin Ø 6 mm

Angle:

0°

Shape: slot, Width W

W = 6,5 mm

Shape: slot, Length P

P = 13,5 mm

Shape cutting length: l

12 mm

Length: l₁

28 mm

Diameter: d₂

32 mm

Type:

with shoulder

ISO 8977

Execution:

slot

Matrix

Order No

= (3)

Order Code character

= (A)

= 0650

= 1350

Order No

= (8)

Order Code character

= (F)

Order No

= (10)

Order No

= (7)

Order No

= (4)

= 26

MATRIXES WITH SHOULDER, CYLINDRICAL, ISO 8977, ANTI-ROTATION ELEMENTS

Anti-rotation element 1 (1)

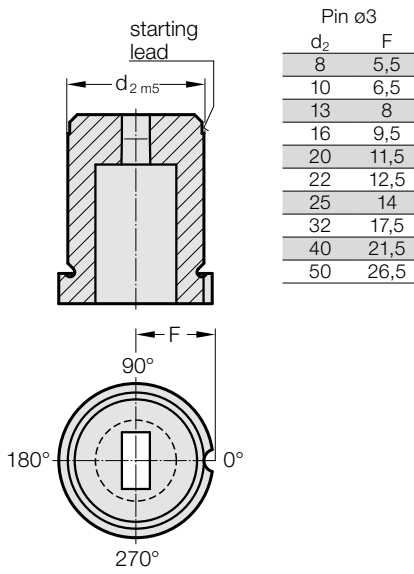

Anti-rotation element 2 (2)

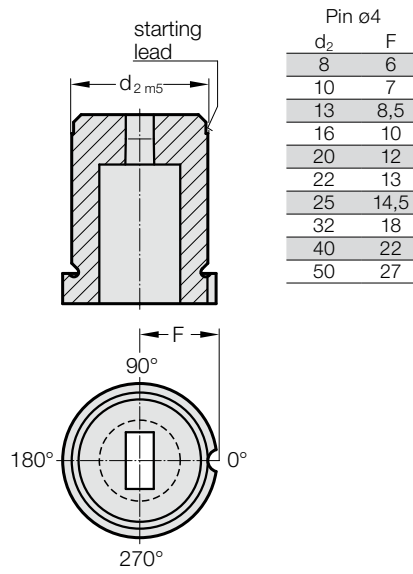

Anti-rotation element 3 (3)

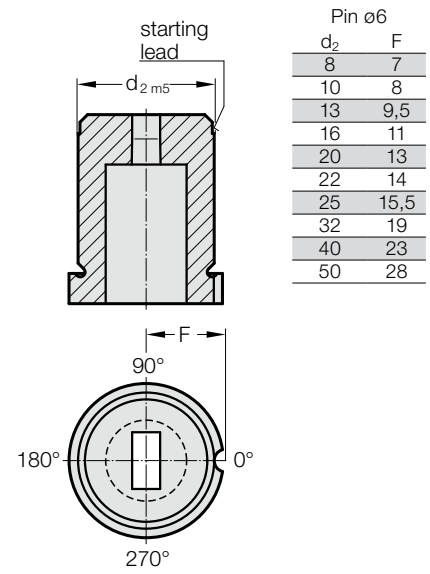

Anti-rotation element 4 (4)

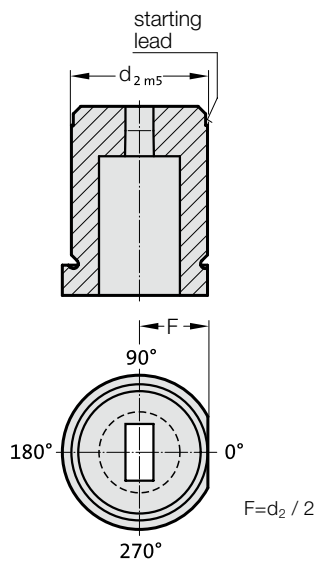

MATRIX WITH SHOULDER, RECTANGLE WITH RADIUSSED CORNERS, ISO 8977



2657.

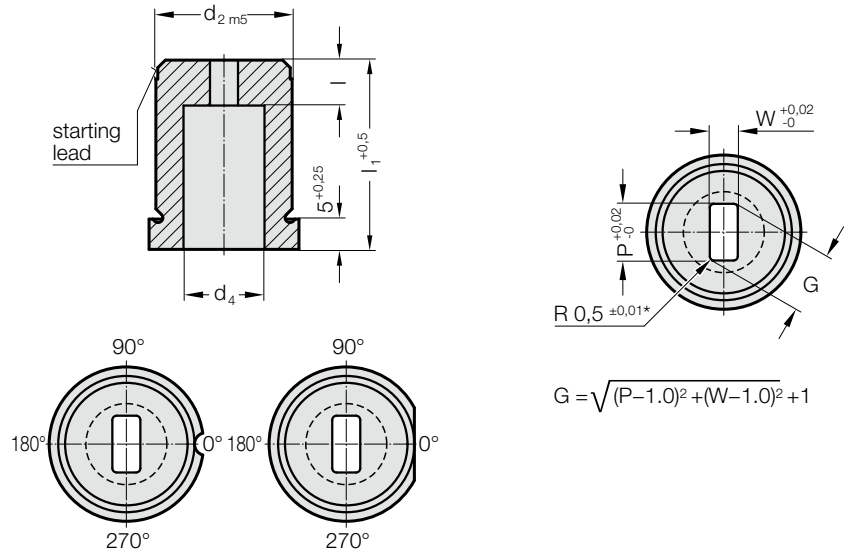

2657. Matrix with shoulder, rectangle with radiussed corners, ISO 8977

d ₂ / Order No	d ₃	d ₄	W _{min}	G _{max}	l / Order No	l ₁ / (Order Code character)	16 (B)	20 (C)	22 (D)	25 (E)	28 (F)	30 (G)	32 (H)	35 (J)
8 / (3)	11	4	1.2	3.5	4 (3)		●	●	●	●	●	●	●	●
10 / (4)	13	5.8	1.2	5	4 (3) 8 (6)		●	●	●	●	●	●	●	●
13 / (5)	16	8	2	7	5 (4) 8 (6)		●	●	●	●	●	●	●	●
16 / (6)	19	9.5	2.4	9	5 (4) 8 (6)		●	●	●	●	●	●	●	●
20 / (7)	23	12	3.2	11	8 (6) 12 (8)		●	●	●	●	●	●	●	●
22 / (8)	25	15	4	14	8 (6) 12 (8)		●	●	●	●	●	●	●	●
25 / (9)	28	17.3	4.8	16	8 (6) 12 (8)		●	●	●	●	●	●	●	●
32 / (10)	35	20.7	5.5	20	8 (6) 12 (8)		●	●	●	●	●	●	●	●
38 / (11)	41	27.7	6.4	27	8 (6) 12 (8)		●	●	●	●	●	●	●	●
40 / (12)	43	27.7	6.4	27	8 (6) 12 (8)		●	●	●	●	●	●	●	●
50 / (14)	53	37	6.4	36	8 (6) 12 (8)		●	●	●	●	●	●	●	●

Material:

HSS
Hardness 62 ± 2 HRC

Execution:

Diameter d₂, starting lead and face surfaces ground.

Special dimensions on request.

* For other radius options, see standardised special shapes.

Ordering Code (example): with anti-rotation element

2657.10F8.1350.0650.A1

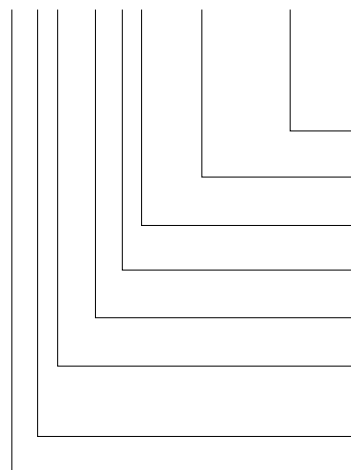

Anti-rotation element:

Pin Ø 3 mm

Angle:

0°

Shape: rectangle with radiussed corners, Width W

W = 6,5 mm

Shape: rectangle with radiussed corners, Length P

P = 13,5 mm

Shape cutting length: l

12 mm

Length: l₁

28 mm

Diameter: d₂

32 mm

Type:

with shoulder

ISO 8977

Execution:

rectangle with radiussed corners

Matrix

Order No

= (3)

Order Code character

= (A)

Order Code character

= 0650

Order Code character

= 1350

Order No

= (8)

Order Code character

= (F)

Order No

= (10)

Order No

= (7)

Order No

= (5)

Order No

= 26

MATRIXES WITH SHOULDER, CYLINDRICAL, ISO 8977, ANTI-ROTATION ELEMENTS

Anti-rotation element 1 (1)

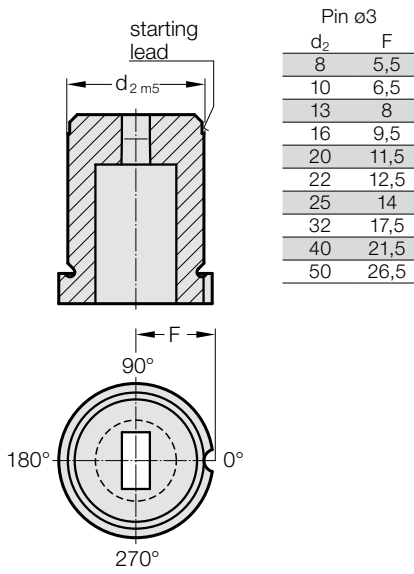

Anti-rotation element 2 (2)

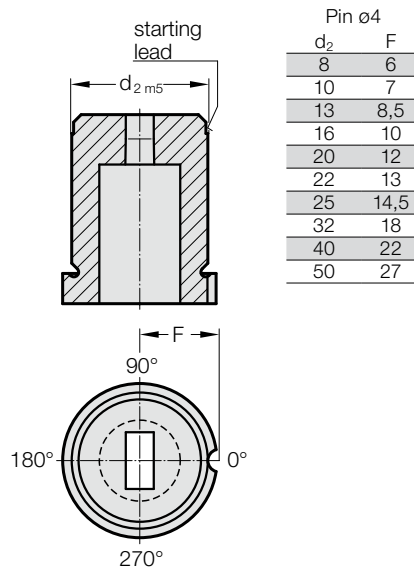

Anti-rotation element 3 (3)

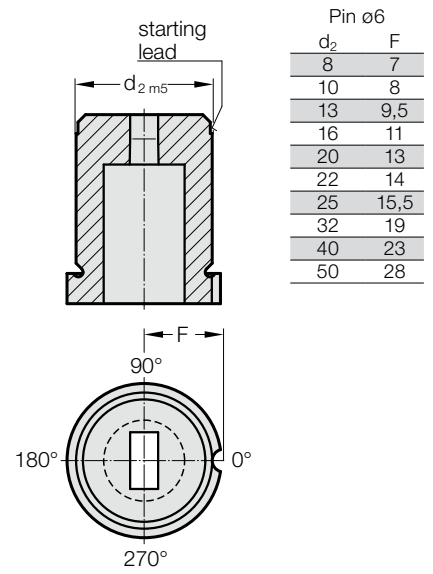

Anti-rotation element 4 (4)

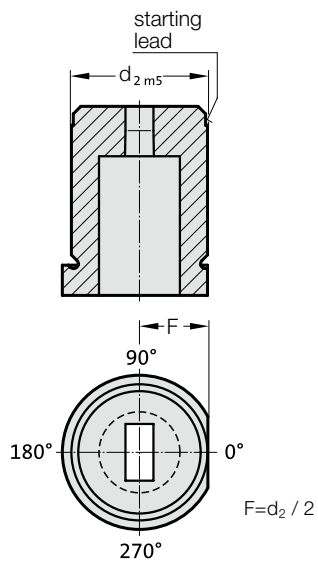

MATRIXES, AUTOMOTIVE STANDARD



MATRIX WITHOUT SHOULDER, BLANK, AUTOMOTIVE STANDARD

2605.

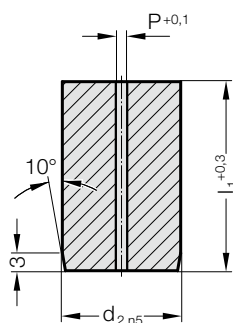

2605. Matrix without shoulder, blank, Automotive Standard

d ₂ / Order No	P	l ₁ / (Order Code character)	13 (A)	16 (B)	20 (C)	22 (D)	25 (E)	28 (F)	30 (G)	32 (H)	35 (J)	40 (K)
10 / (4)	0.8		●	●	●	●	●	●	●	●	●	
13 / (5)	0.8		●	●	●	●	●	●	●	●	●	
16 / (6)	1.5				●	●	●	●	●	●	●	
20 / (7)	1.5				●	●	●	●	●	●	●	
22 / (8)	1.5					●	●	●	●	●	●	
25 / (9)	1.5				●	●	●	●	●	●	●	
32 / (10)	1.5				●	●	●	●	●	●	●	
38 / (11)	1.5				●	●	●	●	●	●	●	●
40 / (12)	1.5					●	●	●	●	●	●	●
45 / (13)	1.5					●	●	●	●	●	●	●
50 / (14)	1.5					●	●	●	●	●	●	●
56 / (15)	1.5					●	●	●	●	●	●	●
63 / (16)	1.5					●	●	●	●	●	●	●
71 / (17)	1.5					●	●	●	●	●	●	●
76 / (18)	1.5						●	●	●	●	●	●
85 / (19)	1.5						●	●	●	●	●	●
90 / (20)	1.5						●	●	●	●	●	●
100 / (21)	1.5						●	●	●	●	●	●

Ordering Code (example):

2605.10F

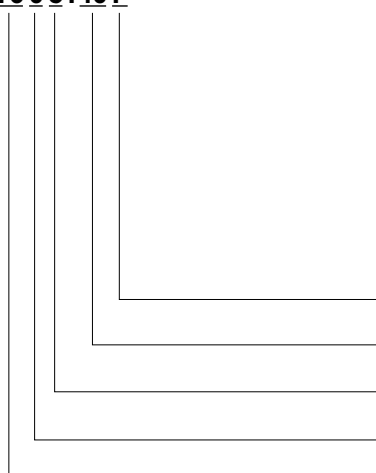

Length: l
28 mm
Diameter: d₂
32 mm
Type: without shoulder
Automotive Standard
Execution:
Blank (pilot hole bore)
Matrix

Order Code character
= (F)
Order No
= (10)
Order No
= (5)
Order No
= (0)
= 26

Material:

HSS
Hardness 62 ± 2 HRC

Execution:

Diameter d₂ and face surfaces ground.
Diameter P is a bored pilot hole for wire EDM.
Special dimensions on request.

MATRIX WITHOUT SHOULDER, ROUND, AUTOMOTIVE STANDARD



2615.

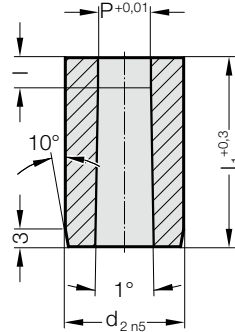

2615. Matrix without shoulder, round, Automotive Standard

d ₂ / Order No	P	I / Order No	l ₁ / (Order Code character)	13 (A)	16 (B)	20 (C)	22 (D)	25 (E)	28 (F)	30 (G)	32 (H)	35 (J)	40 (K)
10 / (4)	1,6 - 6,8	3 (2) 4 (3) 5 (4)		●	●	●	●	●	●	●	●	●	
13 / (5)	3 - 8,8	3 (2) 5 (4) 8 (6)		●	●	●	●	●	●	●	●	●	
16 / (6)	7,4 - 10,8	3 (2) 5 (4) 8 (6)				●	●	●	●	●	●	●	
20 / (7)	9,5 - 13,6	3 (2) 5 (4) 10 (7)				●	●	●	●	●	●	●	
22 / (8)	10,5 - 15	3 (2) 6 (5) 10 (7)				●	●	●	●	●	●	●	
25 / (9)	12 - 17	3 (2) 6 (5) 10 (7)				●	●	●	●	●	●	●	
32 / (10)	16 - 22	3 (2) 6 (5) 12 (8)				●	●	●	●	●	●	●	
38 / (11)	18 - 27	3 (2) 8 (6) 12 (8)				●	●	●	●	●	●	●	●
40 / (12)	18 - 27	3 (2) 8 (6) 12 (8)					●	●	●	●	●	●	●
45 / (13)	18 - 35	3 (2) 8 (6) 12 (8)					●	●	●	●	●	●	●
50 / (14)	18 - 40	3 (2) 8 (6) 12 (8)					●	●	●	●	●	●	●
56 / (15)	18 - 45	3 (2) 8 (6) 12 (8)					●	●	●	●	●	●	●
63 / (16)	18 - 50	3 (2) 8 (6) 12 (8)					●	●	●	●	●	●	●
71 / (17)	18 - 56	3 (2) 8 (6) 12 (8)					●	●	●	●	●	●	●
76 / (18)	25 - 60	3 (2) 8 (6) 12 (8)						●	●	●	●	●	●
85 / (19)	25 - 66	3 (2) 8 (6) 12 (8)						●	●	●	●	●	●
90 / (20)	32 - 70	3 (2) 8 (6) 12 (8)						●	●	●	●	●	●
100 / (21)	32 - 78	3 (2) 8 (6) 12 (8)						●	●	●	●	●	●

Material:

HSS
Hardness 62 ± 2 HRC

Execution:

Diameter d₂ and end faces ground.
Special dimensions on request.

Ordering Code (example): without / with anti-rotation element

2615.10F8.2190/.A3

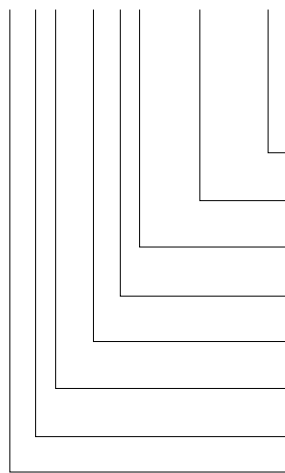

Anti-rotation element:

Pin Ø 6 mm

Angle:

0°

Shape: round

P = Ø 21,9 mm

Shape cutting length: l

12 mm

Length: l₁

28 mm

Diameter: d₂

32 mm

Type: without shoulder
Automotive Standard

Execution:

round

Matrix

Order No

= (3)

Order Code character

= (A)

= (2190)

Order No

= (8)

Order Code character

= (F)

Order No

= (10)

Order No

= (5)

Order No

= (1)

= 26

MATRIXES WITHOUT SHOULDER, AUTOMOTIVE STANDARD, ANTI-ROTATION ELEMENTS

Anti-rotation element 1 (1)

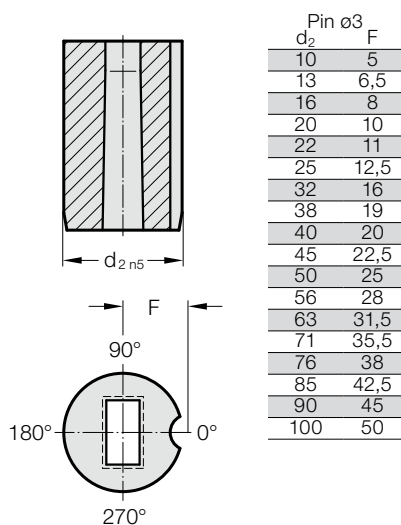

Anti-rotation element 2 (2)

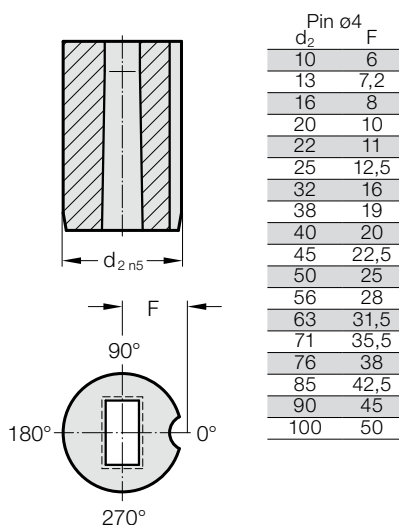

Anti-rotation element 3 (3)

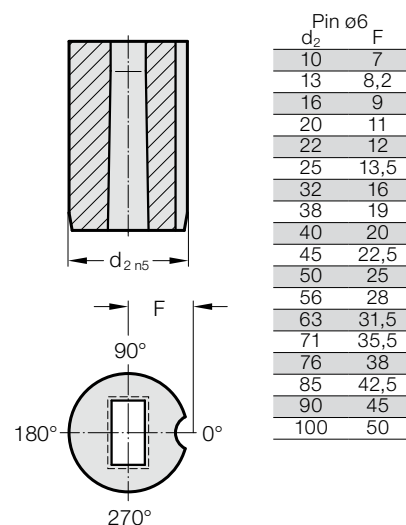

Anti-rotation element 4 (4)

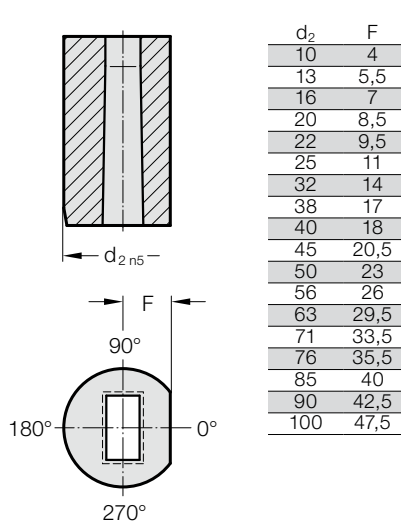

Anti-rotation element 5 (5)

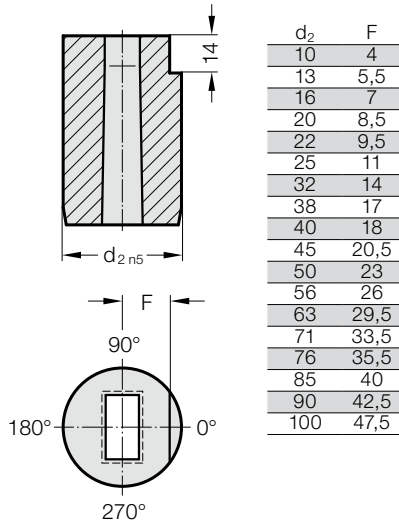

Anti-rotation element 6 (6)

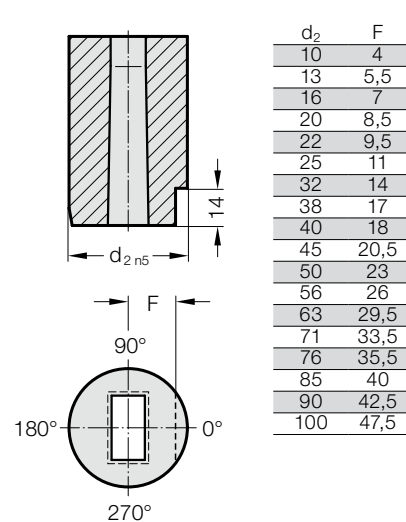

MATRIX WITHOUT SHOULDER, SQUARE, AUTOMOTIVE STANDARD



2625.

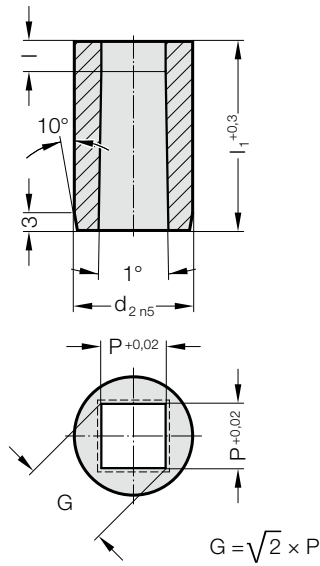

2625. Matrix without shoulder, square, Automotive Standard

d ₂ / Order No	P _{min}	G _{max}	I / Order No	I ₁ / (Order Code character)	13 (A)	16 (B)	20 (C)	22 (D)	25 (E)	28 (F)	30 (G)	32 (H)	35 (J)	40 (K)
10 / (4)	1.3	6.8	3 (2) 4 (3) 5 (4)		●	●	●	●	●	●	●	●	●	●
13 / (5)	1.9	8.8	3 (2) 5 (4) 8 (6)		●	●	●	●	●	●	●	●	●	●
16 / (6)	1.9	10.8	3 (2) 5 (4) 8 (6)				●	●	●	●	●	●	●	●
20 / (7)	1.9	13.6	3 (2) 5 (4) 10 (7)				●	●	●	●	●	●	●	●
22 / (8)	1.9	15	3 (2) 6 (5) 10 (7)				●	●	●	●	●	●	●	●
25 / (9)	1.9	17	3 (2) 6 (5) 10 (7)				●	●	●	●	●	●	●	●
32 / (10)	1.9	22	3 (2) 6 (5) 12 (8)				●	●	●	●	●	●	●	●
38 / (11)	1.9	27	3 (2) 8 (6) 12 (8)				●	●	●	●	●	●	●	●
40 / (12)	1.9	27	3 (2) 8 (6) 12 (8)				●	●	●	●	●	●	●	●
45 / (13)	2.4	35	3 (2) 8 (6) 12 (8)				●	●	●	●	●	●	●	●
50 / (14)	4	40	3 (2) 8 (6) 12 (8)				●	●	●	●	●	●	●	●
56 / (15)	4	45	3 (2) 8 (6) 12 (8)				●	●	●	●	●	●	●	●
63 / (16)	4	50	3 (2) 8 (6) 12 (8)				●	●	●	●	●	●	●	●
71 / (17)	4	56	3 (2) 8 (6) 12 (8)				●	●	●	●	●	●	●	●
76 / (18)	5.6	60	3 (2) 8 (6) 12 (8)				●	●	●	●	●	●	●	●
85 / (19)	5.6	66	3 (2) 8 (6) 12 (8)				●	●	●	●	●	●	●	●
90 / (20)	5.6	70	3 (2) 8 (6) 12 (8)				●	●	●	●	●	●	●	●
100 / (21)	5.6	78	3 (2) 8 (6) 12 (8)				●	●	●	●	●	●	●	●

Material:

HSS
Hardness 62 ± 2 HRC

Execution:

Diameter d₂ and end faces ground.
Special dimensions on request.

Note:

With kerf ≤ 0.04 mm, FIBRO rounds off sharp edges if the punch and piercing die bush are ordered together. This reduces the fitting time and the risk of an edge break during operation.

Ordering Code (example): with anti-rotation element

2625.10F8.1350.A3

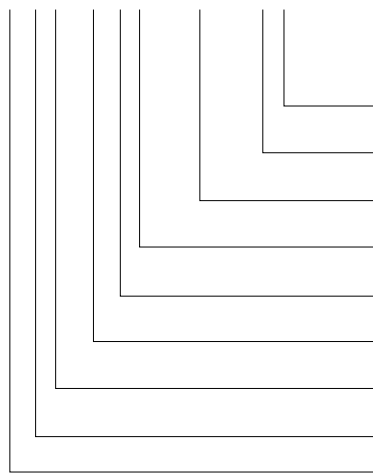

Anti-rotation element:

Pin ∅ 6 mm

Angle:

0°

Shape: square, Length P

P = 13,5 mm

Shape cutting length: l

12 mm

Length: l₁

28 mm

Diameter: d₂

32 mm

Type: without shoulder

Automotive Standard

Execution:

square

Matrix

Order No

= (3)

Order Code character

= (A)

= (1350)

Order No

= (8)

Order Code character

= (F)

Order No

= (10)

Order No

= (5)

Order No

= (2)

= 26

MATRIXES WITHOUT SHOULDER, AUTOMOTIVE STANDARD, ANTI-ROTATION ELEMENTS

Anti-rotation element 1 (1)

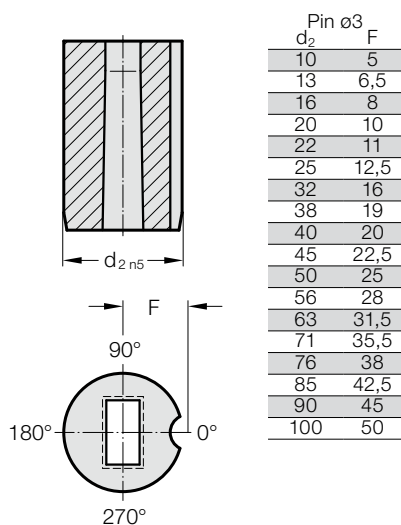

Anti-rotation element 2 (2)

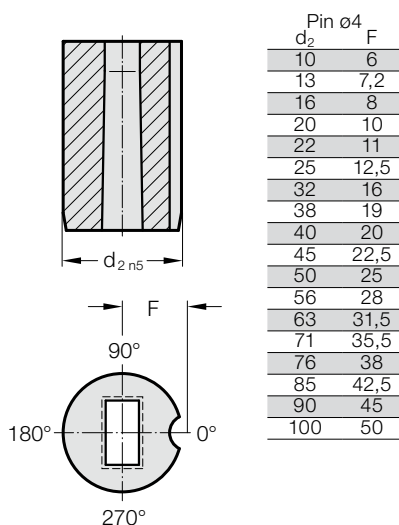

Anti-rotation element 3 (3)

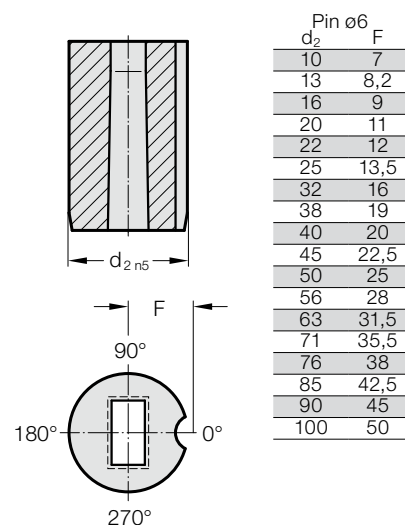

Anti-rotation element 4 (4)

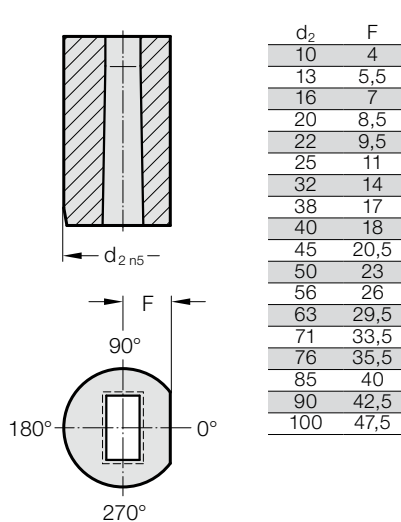

Anti-rotation element 5 (5)

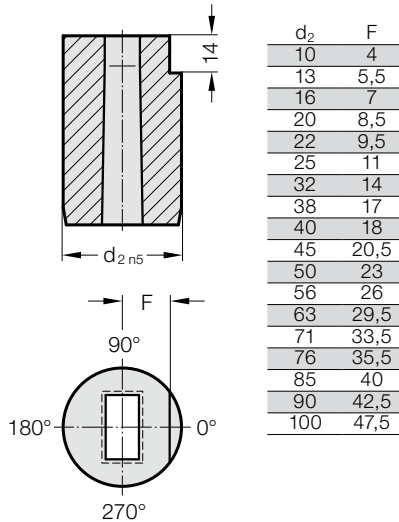

Anti-rotation element 6 (6)

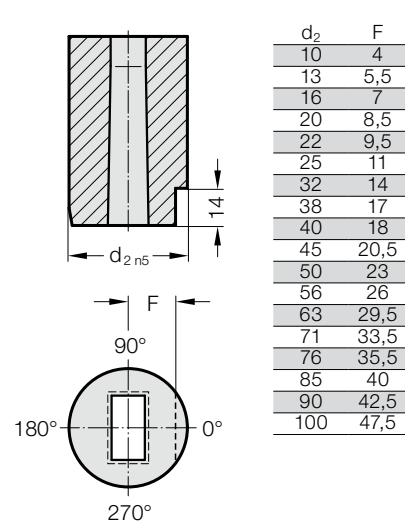

MATRIX WITHOUT SHOULDER, RECTANGULAR, AUTOMOTIVE STANDARD



2635.

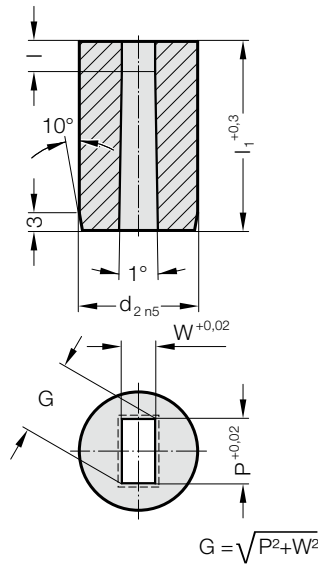

2635. Matrix without shoulder, rectangular, Automotive Standard

d ₂ / Order No	W _{min}	G _{max}	I / Order No	I ₁ / (Order Code character)	13	16	20	22	25	28	30	32	35	40
					(A)	(B)	(C)	(D)	(E)	(F)	(G)	(H)	(J)	(K)
10 / (4)	1.3	6.8	3 (2) 4 (3) 5 (4)		●	●	●	●	●	●	●	●	●	●
13 / (5)	1.9	8.8	3 (2) 5 (4) 8 (6)		●	●	●	●	●	●	●	●	●	●
16 / (6)	1.9	10.8	3 (2) 5 (4) 8 (6)				●	●	●	●	●	●	●	●
20 / (7)	1.9	13.6	3 (2) 5 (4) 10 (7)				●	●	●	●	●	●	●	●
22 / (8)	1.9	15	3 (2) 6 (5) 10 (7)				●	●	●	●	●	●	●	●
25 / (9)	1.9	17	3 (2) 6 (5) 10 (7)				●	●	●	●	●	●	●	●
32 / (10)	1.9	22	3 (2) 6 (5) 12 (8)				●	●	●	●	●	●	●	●
38 / (11)	1.9	27	3 (2) 8 (6) 12 (8)				●	●	●	●	●	●	●	●
40 / (12)	1.9	27	3 (2) 8 (6) 12 (8)				●	●	●	●	●	●	●	●
45 / (13)	2.4	35	3 (2) 8 (6) 12 (8)				●	●	●	●	●	●	●	●
50 / (14)	4	40	3 (2) 8 (6) 12 (8)				●	●	●	●	●	●	●	●
56 / (15)	4	45	3 (2) 8 (6) 12 (8)				●	●	●	●	●	●	●	●
63 / (16)	4	50	3 (2) 8 (6) 12 (8)				●	●	●	●	●	●	●	●
71 / (17)	4	56	3 (2) 8 (6) 12 (8)				●	●	●	●	●	●	●	●
76 / (18)	5.6	60	3 (2) 8 (6) 12 (8)				●	●	●	●	●	●	●	●
85 / (19)	5.6	66	3 (2) 8 (6) 12 (8)				●	●	●	●	●	●	●	●
90 / (20)	5.6	70	3 (2) 8 (6) 12 (8)				●	●	●	●	●	●	●	●
100 / (21)	5.6	78	3 (2) 8 (6) 12 (8)				●	●	●	●	●	●	●	●

Material:

HSS
Hardness 62 ± 2 HRC

Execution:

Diameter d₂ and end faces ground.
Special dimensions on request.

Note:

With kerf ≤ 0.04 mm, FIBRO rounds off sharp edges if the punch and piercing die bush are ordered together. This reduces the fitting time and the risk of an edge break during operation.

Ordering Code (example): with anti-rotation element

2635.10F8.1350.0650.A3

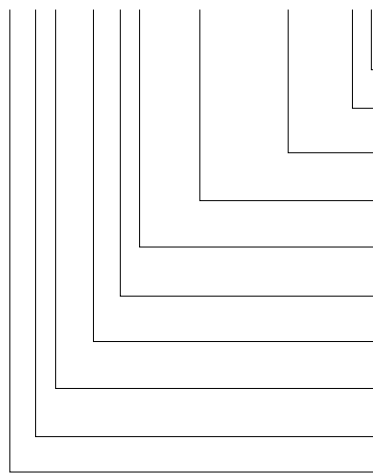

Anti-rotation element:

Pin ∅ 6 mm

Angle:

0°

Shape: rectangular, Width W

W = 6,5 mm

Shape: rectangular, Length P

P = 13,5 mm

Shape cutting length: l

12 mm

Length: l₁

28 mm

Diameter: d₂

32 mm

Type: without shoulder

Automotive Standard

Execution:

rectangular

Matrix

Order No

= (3)

Order Code character

= (A)

= (0650)

= (1350)

Order No

= (8)

Order Code character

= (F)

Order No

= (10)

Order No

= (5)

Order No

= (3)

= 26

MATRIXES WITHOUT SHOULDER, AUTOMOTIVE STANDARD, ANTI-ROTATION ELEMENTS

Anti-rotation element 1 (1)

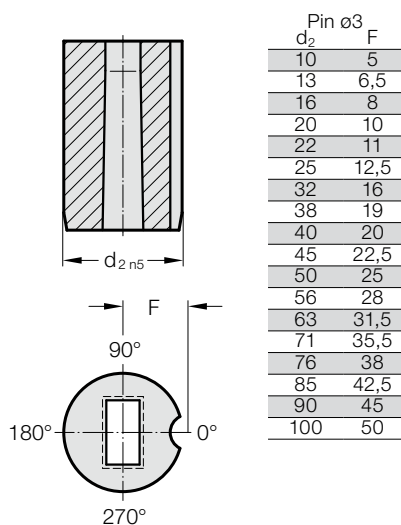

Anti-rotation element 2 (2)

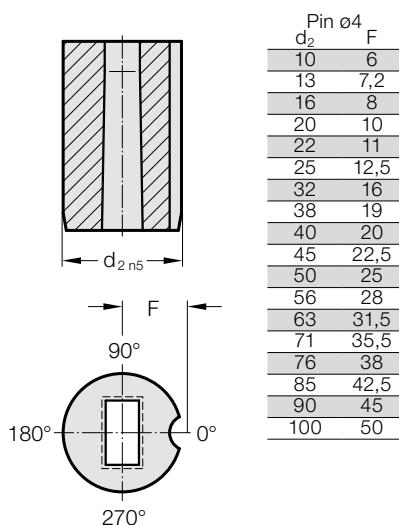

Anti-rotation element 3 (3)

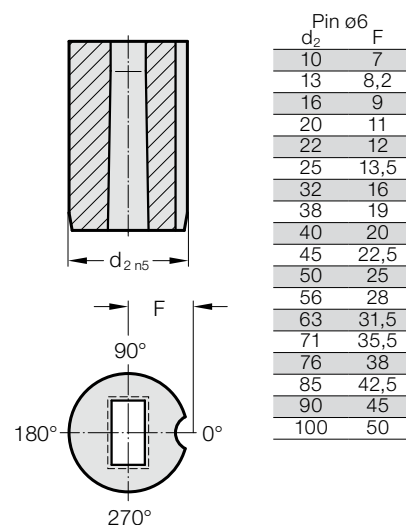

Anti-rotation element 4 (4)

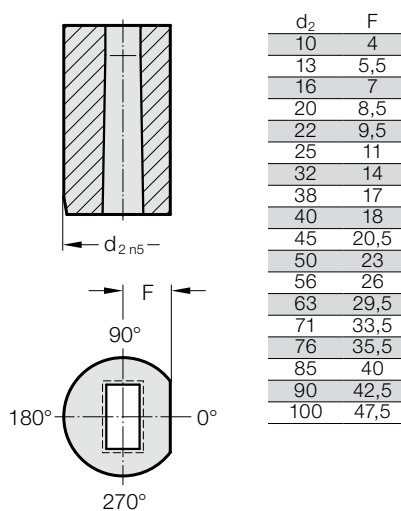

Anti-rotation element 5 (5)

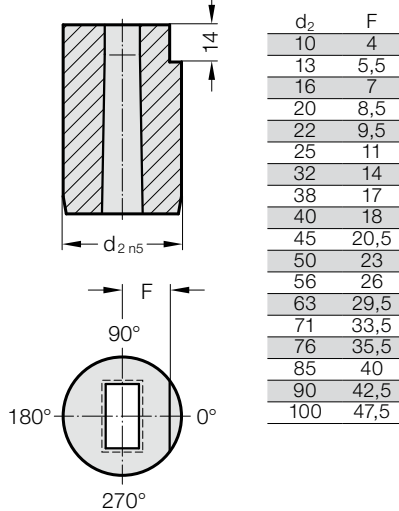

Anti-rotation element 6 (6)

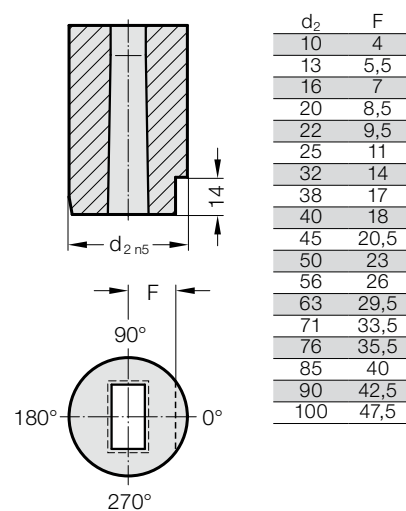

MATRIX WITHOUT SHOULDER, SLOT, AUTOMOTIVE STANDARD



2645.

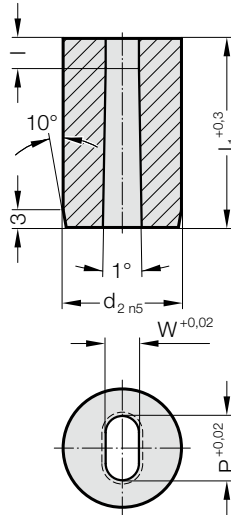

G = P

2645. Matrix without shoulder, slot, Automotive Standard

d ₂ / Order No	W _{min}	G _{max}	I / Order No	I ₁ / (Order Code character)	13	16	20	22	25	28	30	32	35	40
					(A)	(B)	(C)	(D)	(E)	(F)	(G)	(H)	(J)	(K)
10 / (4)	1.3	6.8	3 (2) 4 (3) 5 (4)		●	●	●	●	●	●	●	●	●	●
13 / (5)	1.9	8.8	3 (2) 5 (4) 8 (6)		●	●	●	●	●	●	●	●	●	●
16 / (6)	1.9	10.8	3 (2) 5 (4) 8 (6)				●	●	●	●	●	●	●	●
20 / (7)	1.9	13.6	3 (2) 5 (4) 10 (7)				●	●	●	●	●	●	●	●
22 / (8)	1.9	15	3 (2) 6 (5) 10 (7)				●	●	●	●	●	●	●	●
25 / (9)	1.9	17	3 (2) 6 (5) 10 (7)				●	●	●	●	●	●	●	●
32 / (10)	1.9	22	3 (2) 6 (5) 12 (8)				●	●	●	●	●	●	●	●
38 / (11)	1.9	27	3 (2) 8 (6) 12 (8)				●	●	●	●	●	●	●	●
40 / (12)	1.9	27	3 (2) 8 (6) 12 (8)				●	●	●	●	●	●	●	●
45 / (13)	2.4	35	3 (2) 8 (6) 12 (8)				●	●	●	●	●	●	●	●
50 / (14)	4	40	3 (2) 8 (6) 12 (8)				●	●	●	●	●	●	●	●
56 / (15)	4	45	3 (2) 8 (6) 12 (8)				●	●	●	●	●	●	●	●
63 / (16)	4	50	3 (2) 8 (6) 12 (8)				●	●	●	●	●	●	●	●
71 / (17)	4	56	3 (2) 8 (6) 12 (8)				●	●	●	●	●	●	●	●
76 / (18)	5.6	60	3 (2) 8 (6) 12 (8)				●	●	●	●	●	●	●	●
85 / (19)	5.6	66	3 (2) 8 (6) 12 (8)				●	●	●	●	●	●	●	●
90 / (20)	5.6	70	3 (2) 8 (6) 12 (8)				●	●	●	●	●	●	●	●
100 / (21)	5.6	78	3 (2) 8 (6) 12 (8)				●	●	●	●	●	●	●	●

Material:

HSS

Hardness 62 ± 2 HRC

Execution:

Diameter d₂ and end faces ground.

Special dimensions on request.

Ordering Code (example): with anti-rotation element

2645.10F8.1350.0650.A3

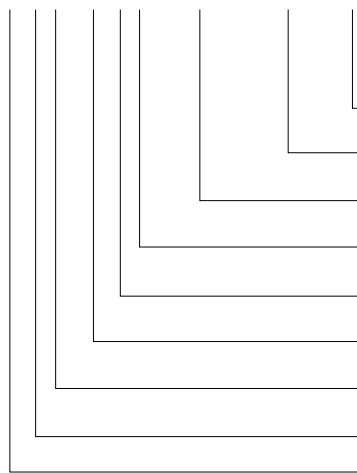

Anti-rotation element:

Pin ∅ 6 mm

Angle:

0°

Shape: slot, Width W

W = 6,5 mm

Shape: slot, Length P

P = 13,5 mm

Shape cutting length: l

12 mm

Length: l₁

28 mm

Diameter: d₂

32 mm

Type: without shoulder

Automotive Standard

Execution:

slot

Matrix

Order No

= (3)

Order Code character

= (A)

= (0650)

= (1350)

Order No

= (8)

Order Code character

= (F)

Order No

= (10)

Order No

= (5)

Order No

= (4)

= 26

MATRIXES WITHOUT SHOULDER, AUTOMOTIVE STANDARD, ANTI-ROTATION ELEMENTS

Anti-rotation element 1 (1)

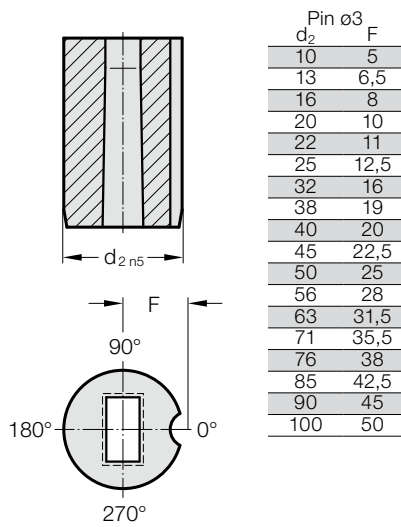

Anti-rotation element 2 (2)

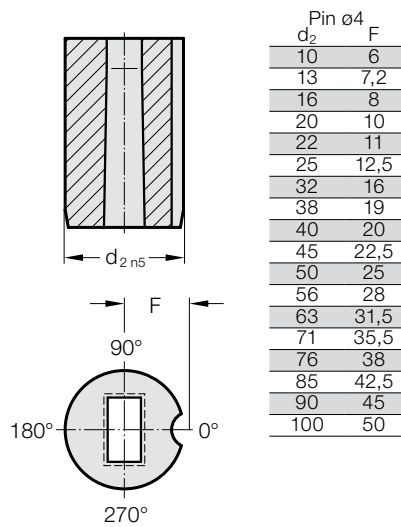

Anti-rotation element 3 (3)

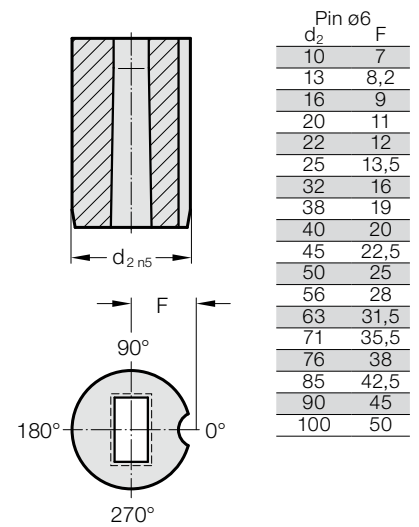

Anti-rotation element 4 (4)

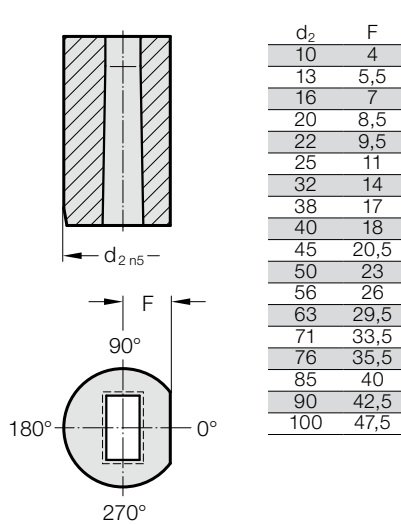

Anti-rotation element 5 (5)

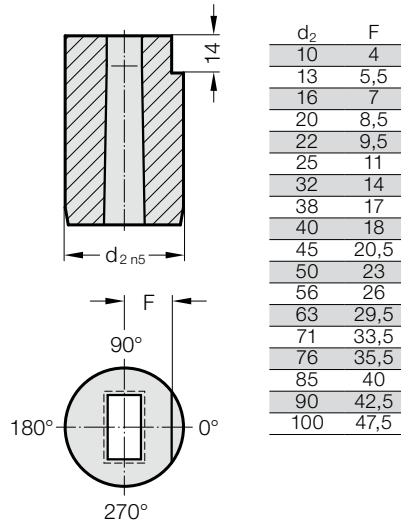

Anti-rotation element 6 (6)

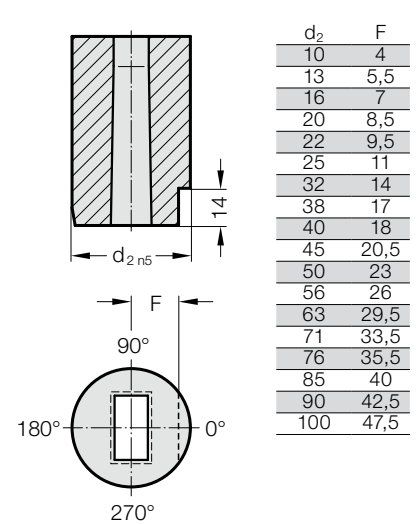

MATRIX WITHOUT SHOULDER, RECTANGLE WITH RADIUSED CORNERS, AUTOMOTIVE STANDARD



2655.

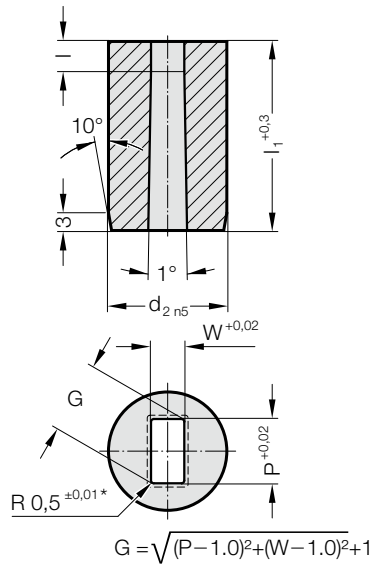

2655. Matrix without shoulder, rectangle with radiused corners, Automotive Standard

d ₂ / Order No	W _{min}	G _{max}	I / Order No	I ₁ / (Order Code character)	13	16	20	22	25	28	30	32	35	40
					(A)	(B)	(C)	(D)	(E)	(F)	(G)	(H)	(J)	(K)
10 / (4)	1.3	6.8	3 (2) 4 (3) 5 (4)		●	●	●	●	●	●	●	●	●	●
13 / (5)	1.9	8.8	3 (2) 5 (4) 8 (6)		●	●	●	●	●	●	●	●	●	●
16 / (6)	1.9	10.8	3 (2) 5 (4) 8 (6)				●	●	●	●	●	●	●	●
20 / (7)	1.9	13.6	3 (2) 5 (4) 10 (7)				●	●	●	●	●	●	●	●
22 / (8)	1.9	15	3 (2) 6 (5) 10 (7)				●	●	●	●	●	●	●	●
25 / (9)	1.9	17	3 (2) 6 (5) 10 (7)				●	●	●	●	●	●	●	●
32 / (10)	1.9	22	3 (2) 6 (5) 12 (8)				●	●	●	●	●	●	●	●
38 / (11)	1.9	27	3 (2) 8 (6) 12 (8)				●	●	●	●	●	●	●	●
40 / (12)	1.9	27	3 (2) 8 (6) 12 (8)				●	●	●	●	●	●	●	●
45 / (13)	2.4	35	3 (2) 8 (6) 12 (8)				●	●	●	●	●	●	●	●
50 / (14)	4	40	3 (2) 8 (6) 12 (8)				●	●	●	●	●	●	●	●
56 / (15)	4	45	3 (2) 8 (6) 12 (8)				●	●	●	●	●	●	●	●
63 / (16)	4	50	3 (2) 8 (6) 12 (8)				●	●	●	●	●	●	●	●
71 / (17)	4	56	3 (2) 8 (6) 12 (8)				●	●	●	●	●	●	●	●
76 / (18)	5.6	60	3 (2) 8 (6) 12 (8)				●	●	●	●	●	●	●	●
85 / (19)	5.6	66	3 (2) 8 (6) 12 (8)				●	●	●	●	●	●	●	●
90 / (20)	5.6	70	3 (2) 8 (6) 12 (8)				●	●	●	●	●	●	●	●
100 / (21)	5.6	78	3 (2) 8 (6) 12 (8)				●	●	●	●	●	●	●	●

Material:

HSS
Hardness 62 ± 2 HRC

Execution:

Diameter d₂ and end faces ground.
Special dimensions on request.

* For other radius options, see standardised special shapes.

Ordering Code (example): with anti-rotation element

2655.10F8.1350.0650.A3

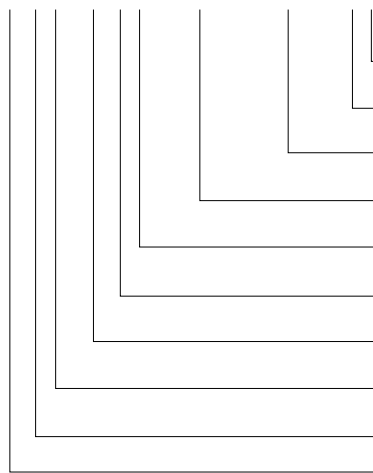

Anti-rotation element: Order No = (3)
Pin ∅ 6 mm
Angle: Order Code character = (A)
0°
Shape: rectangle with radiused corners, Width W = (0650)
W = 6,5 mm
Shape: rectangle with radiused corners, Length P = (1350)
P = 13,5 mm
Shape cutting length: l Order No = (8)
12 mm
Length: l₁ Order Code character = (F)
28 mm
Diameter: d₂ Order No = (10)
32 mm
Type: without shoulder Order No = (5)
Automotive Standard
Execution: Order No = (5)
rectangle with radiused corners
Matrixes = (26)

MATRIXES WITHOUT SHOULDER, AUTOMOTIVE STANDARD, ANTI-ROTATION ELEMENTS

Anti-rotation element 1 (1)

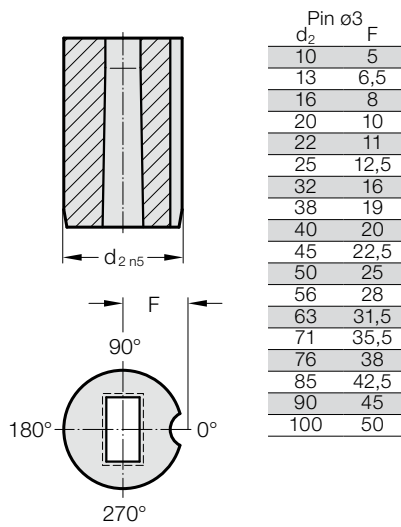

Anti-rotation element 2 (2)

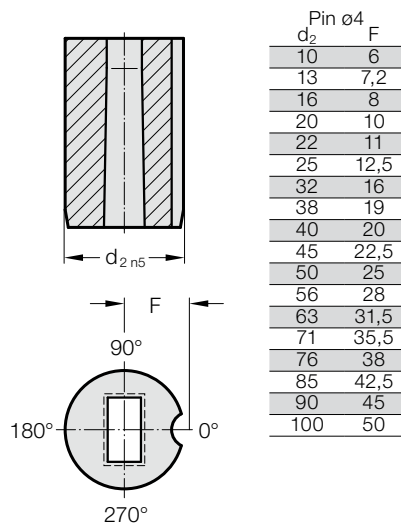

Anti-rotation element 3 (3)

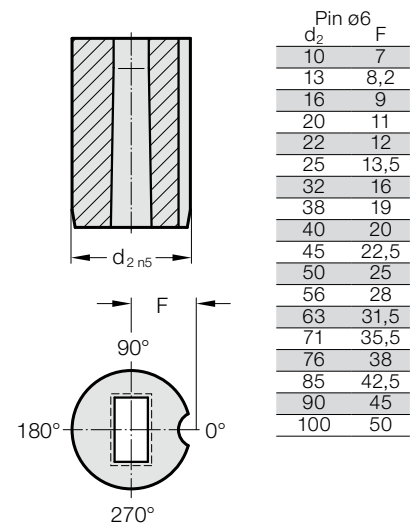

Anti-rotation element 4 (4)

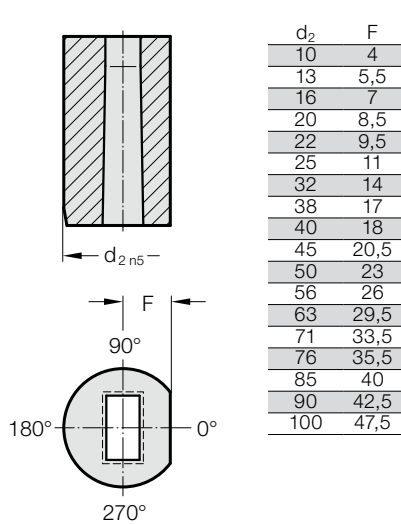

Anti-rotation element 5 (5)

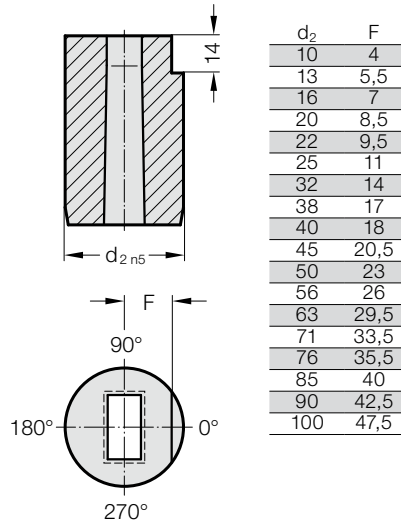

Anti-rotation element 6 (6)

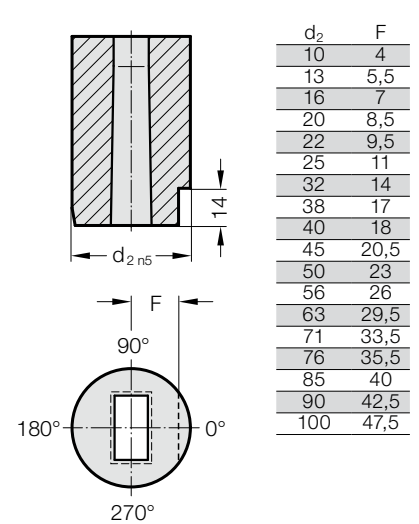

MATRIXES DIN 9845



MATRIX WITHOUT COLLAR, DIN 9845 SHAPE A



260.

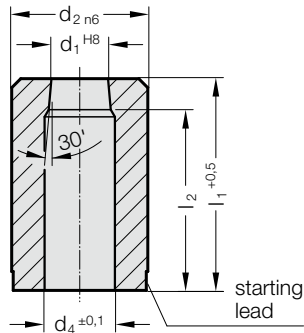

260. Matrix without collar, DIN 9845 Shape A

Gradation		d_2	l_1	20	28
d_1	d_1				
0,5 - 1	0.1	5	l_2	18	
1,1 - 2	0.1	6		17	25
2,1 - 3	0.1	7		17	25
3,1 - 4	0.1	8		17	25
4,1 - 5	0.1	10		16	24
5,1 - 6	0.1	12		16	24
6,1 - 8	0.1	15		16	24
8,1 - 10	0.1	18		16	24
10,1 - 12	0.1	22		15	23
12,1 - 15	0.1	26		15	23
15,1 - 18	0.1	30			

Material:

HSS

Order No 260.3.

Hardness 62 ± 2 HRC

Description of FIBRO materials for tool and die components see at the beginning of Chapter E.

Execution:

Diameters d_1 , d_2 and face surfaces ground.

d_4 : For $d_1 \leq 2$ mm, $d_4 = d_1 + 0,3$

For $d_1 = 2,1$ mm to 4,0 mm, $d_4 = d_1 + 0,5$

For $d_1 = 4,1$ mm to 8,0 mm, $d_4 = d_1 + 0,7$

For $d_1 \geq 8,1$ mm, $d_4 = d_1 + 1$

Other diameters on request.

Ordering Code (example):

Matrix without collar, DIN 9845 Shape A = 260.3.

Cutting diameter d_1 5.1 mm = 0510.

Length l_1 20 mm = 020

Order No = 260.3. 0510. 020

MATRIX WITH COLLAR, DIN 9845 SHAPE B

261.

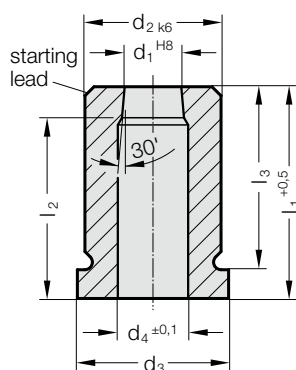

Material:

HSS

Order No 261.3.

Hardness 62 ± 2 HRC

Description of FIBRO materials for tool and die components see at the beginning of Chapter E.

Execution:

Diameters d_1 , d_2 and face surfaces ground.

d_4 : For $d_1 \leq 2$ mm, $d_4 = d_1 + 0,3$

For $d_1 = 2,1$ mm to 4,0 mm, $d_4 = d_1 + 0,5$

For $d_1 = 4,1$ mm to 8,0 mm, $d_4 = d_1 + 0,7$

For $d_1 \geq 8,1$ mm, $d_4 = d_1 + 1$

Other diameters on request.

261. Matrix with collar, DIN 9845 Shape B

d_1	Gradation								
	d_1	d_2	d_3	l_1	20	28	l_1	20	28
0,5 - 1	0.1	5	7	l_2	18		l_3	16	
1,1 - 2	0.1	6	8		17	25		16	24
2,1 - 3	0.1	7	9		17	25		16	24
3,1 - 4	0.1	8	10		17	25		16	24
4,1 - 5	0.1	10	12		16	24		16	24
5,1 - 6	0.1	12	14		16	24		16	24
6,1 - 8	0.1	15	17		16	24		16	24
8,1 - 10	0.1	18	20		16	24		16	24
10,1 - 12	0.1	22	24		15	23		16	24
12,1 - 15	0.1	26	28		15	23		16	24
15,1 - 18	0.1	30	32			23			24

Ordering Code (example):

Matrix with collar, DIN 9845 Shape B = 261.3.

Cutting diameter d_1 5.1 mm = 0510.

Length l_1 20 mm = 020

Order No = 261.3.0510.020

MATRIXES, CYLINDRICAL

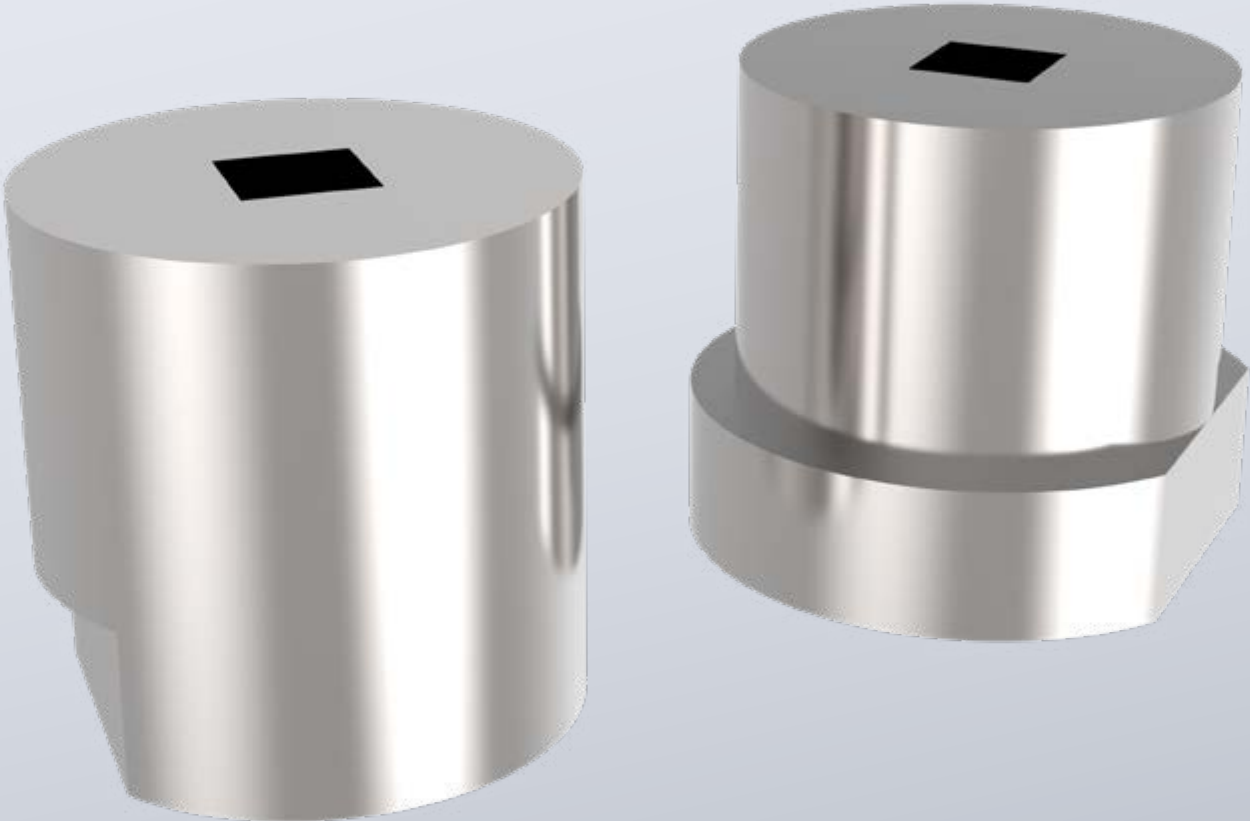

MATRIX WITHOUT COLLAR, CYLINDRICAL



2602.

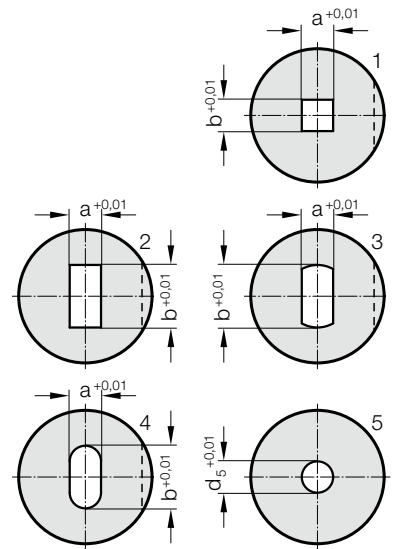
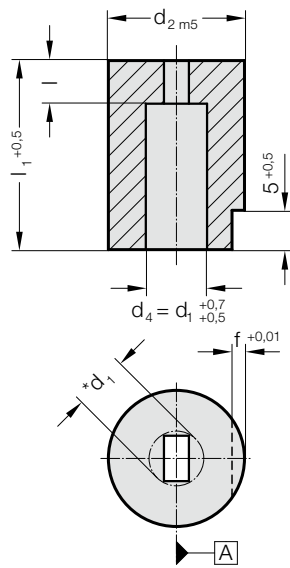

2602. Matrix without collar, cylindrical

d ₁ , d ₅	d ₂	l	f	l ₁	16	19	22	25	28	32
1,8 - 3,2	8	3	1		●	●	●	●	●	●
2 - 5	10	3	1		●	●	●	●	●	●
3 - 7	13	3	1.5		●	●	●	●	●	●
5 - 8	16	5	1.5		●	●	●	●	●	●
7 - 11	20	5	1.5		●	●	●	●	●	●
11 - 16	25	5	2.5		●	●	●	●	●	●
16 - 19	32	7	2.5		●	●	●	●	●	●
19 - 28	40	7	2.5		●	●	●	●	●	●

Material:

HSS

Order No. 2602.3.

Hardness 64 ± 2 HRC

Execution:

Diameter d₂ and end faces ground.

Key flats parallel with reference axis "A" unless otherwise specified.

*d₁ = size over corners

With starting holes for wire-EDM as per 2601.

Ordering Code (example):

Matrix without collar, cylindrical	=	2602.3.
Mount diameter d ₂	20 mm =	020.
Length l ₁	16 mm =	016.
Cutting form Shape	square =	1.
Cutting form width a	320 =	0320.
Cutting form length b	320 =	0320
Order No	=	2602.3. 020. 016. 1. 0320. 0320

MATRIX WITH COLLAR, CYLINDRICAL

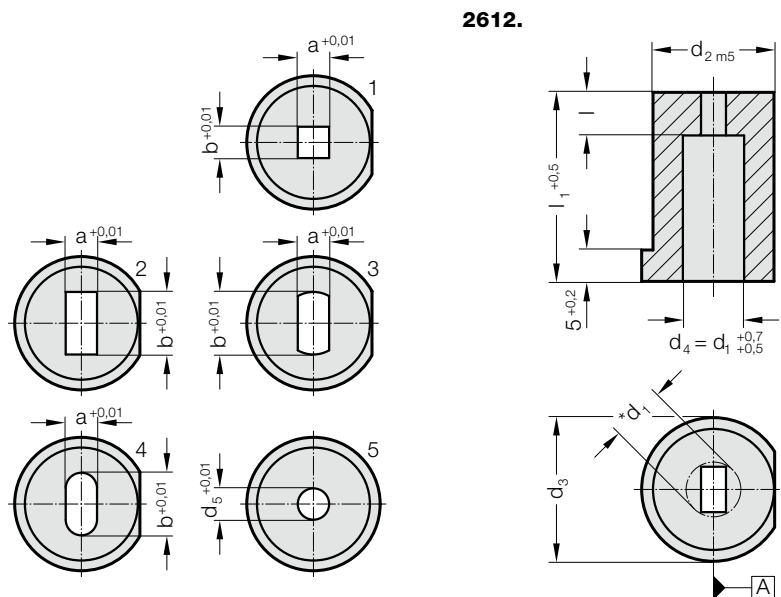

Material:

HSS
 Order No. 2612.3.
 Hardness 64 ± 2 HRC

Execution:

Diameter d_2 and end faces ground.
 Key flats parallel with reference axis "A" unless otherwise specified.
 * d_1 = size over corners

With starting holes for wire-EDM as per 2611.

2612. Matrix with collar, cylindrical

d_1, d_5	d_2	d_3	l	l_1	16	19	22	25	28	32
1,8 - 3,2	8	11	3		●	●	●	●	●	●
2 - 5	10	13	3		●	●	●	●	●	●
3 - 7	13	16	3		●	●	●	●	●	●
5 - 8	16	19	5		●	●	●	●	●	●
7 - 11	20	23	5		●	●	●	●	●	●
11 - 16	25	28	5		●	●	●	●	●	●
16 - 19	32	35	7		●	●	●	●	●	●
19 - 28	40	43	7		●	●	●	●	●	●

Ordering Code (example):

Matrix with collar, cylindrical	=	2612.3.
Mount diameter d_2	20 mm =	020.
Length l_1	16 mm =	016.
Cutting form Shape	square =	1.
Cutting form width a	320 =	0320.
Cutting form length b	320 =	0320
Order No	=	2612.3. 020. 016. 1. 0320. 0320

MATRIXES, CONICAL

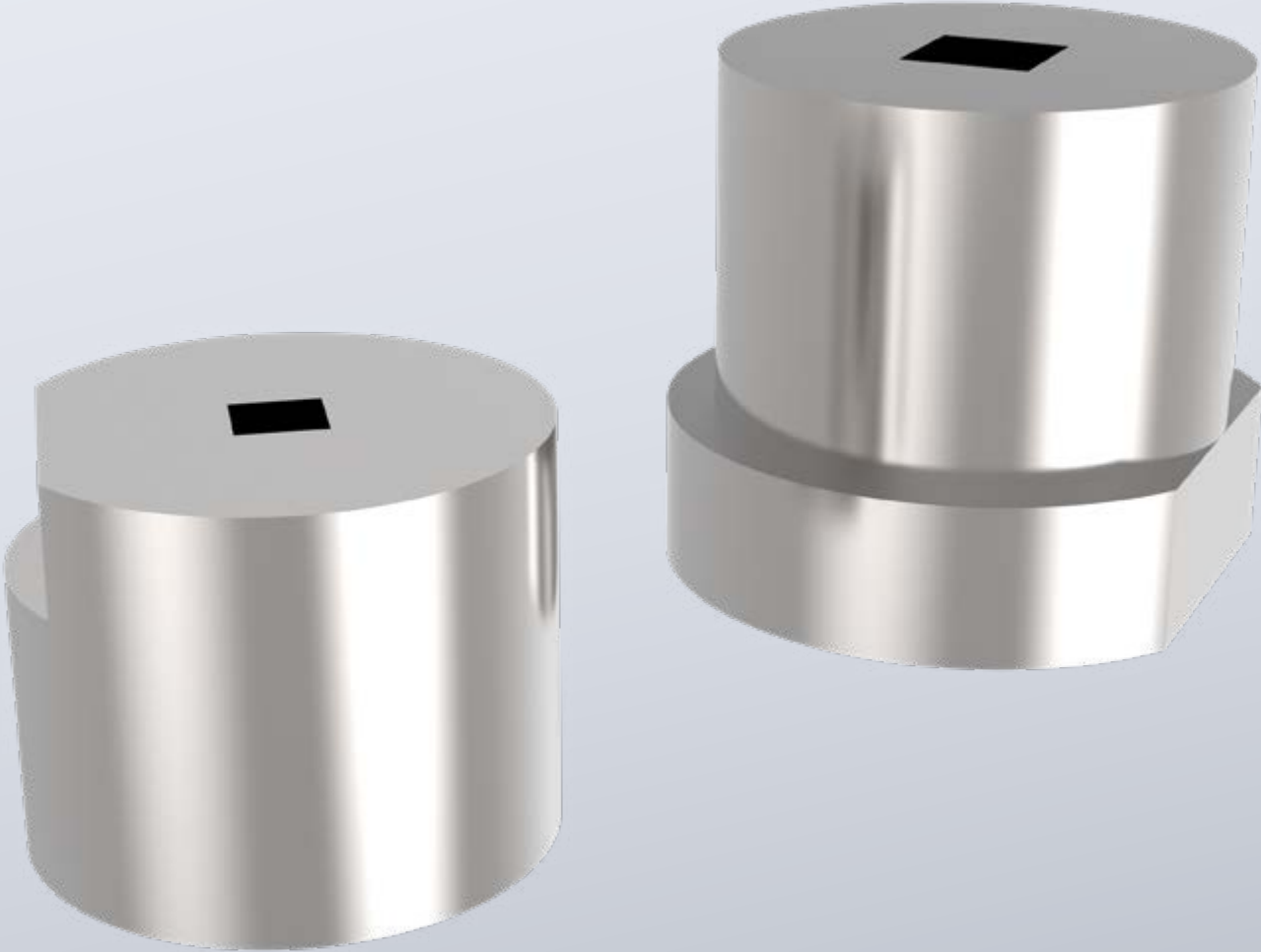

MATRIX WITHOUT COLLAR, CONICAL



2601.

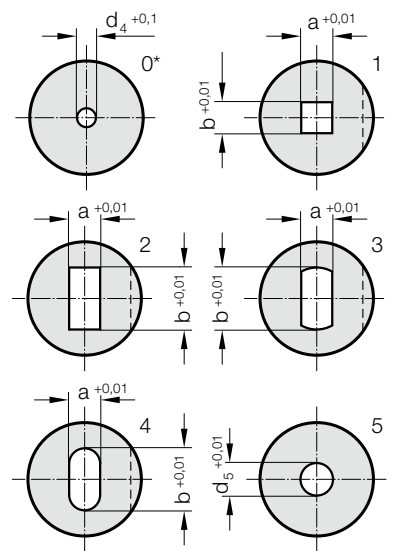
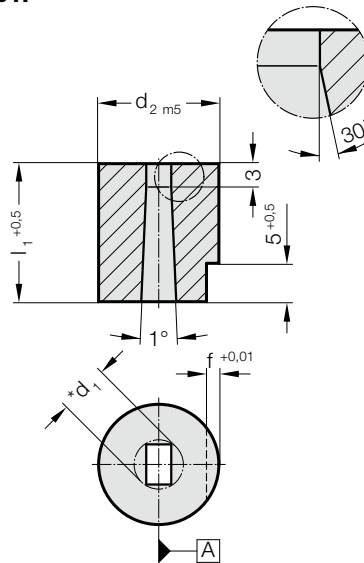

2601. Matrix without collar, conical

d_1, d_5	d_2	d_4	f	l_1	16	19	22	25	28	32
1,8 - 3,2	8	1	1		●	●	●	●	●	●
2 - 5	10	1	1		●	●	●	●	●	●
3 - 7	13	1.5	1.5		●	●	●	●	●	●
5 - 8	16	1.5	1.5		●	●	●	●	●	●
7 - 11	20	1.5	1.5		●	●	●	●	●	●
11 - 16	25	2.5	2.5		●	●	●	●	●	●
16 - 19	32	2.5	2.5		●	●	●	●	●	●
19 - 28	40	2.5	2.5		●	●	●	●	●	●

Material:

HSS

Order No. 2601.3.

Hardness 64 ± 2 HRC

Execution:

Diameter d_2 and end faces ground.

Key flats parallel with reference axis "A" unless otherwise specified.

* d_1 = size over corners

*0 = Execution only with starting hole for wire-EDM

Ordering Code (example):

Matrix without collar, conical	=	2601.3.
Mount diameter d_2	20 mm =	020.
Length l_1	16 mm =	016.
Cutting form Shape	square =	1.
Cutting form width a	320 =	0320.
Cutting form length b	320 =	0320
Order No	=	2601.3. 020. 016. 1. 0320. 0320

MATRIX WITH COLLAR, CONICAL

2611.

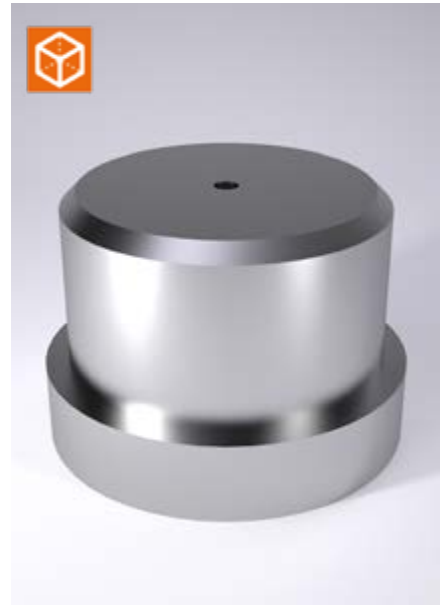
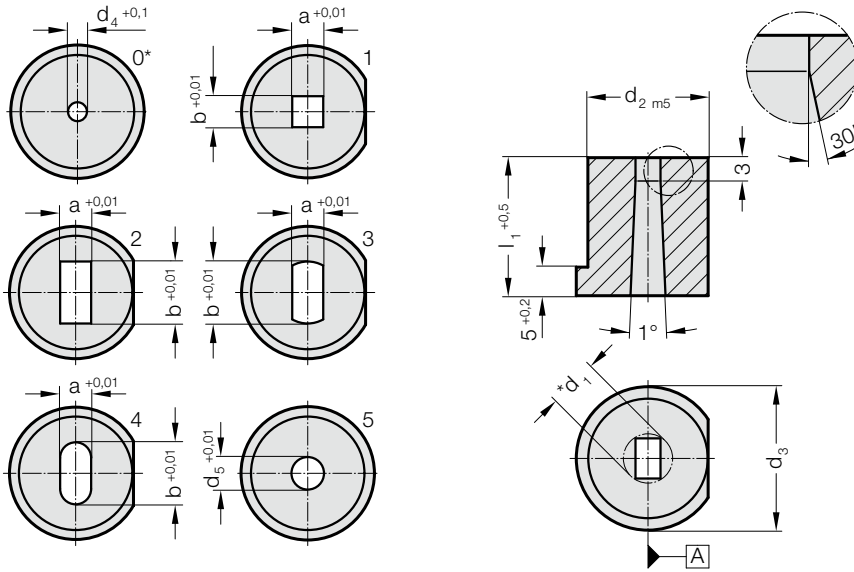

Material:

HSS

Order No. 2611.3.

Hardness 64 ± 2 HRC

Execution:

Diameter d_2 and end faces ground.

Key flats parallel with reference axis "A" unless otherwise specified.

* d_1 = size over corners

*0 = Execution only with starting hole for wire-EDM

2611. Matrix with collar, conical

d_1, d_5	d_2	d_3	d_4	l_1	16	19	22	25	28	32
1,8 - 3,2	8	11	1		●	●	●	●	●	●
2 - 5	10	13	1		●	●	●	●	●	●
3 - 7	13	16	1.5		●	●	●	●	●	●
5 - 8	16	19	1.5		●	●	●	●	●	●
7 - 11	20	23	1.5		●	●	●	●	●	●
11 - 16	25	28	2.5		●	●	●	●	●	●
16 - 19	32	35	2.5		●	●	●	●	●	●
19 - 28	40	43	2.5		●	●	●	●	●	●

Ordering Code (example):

Matrix with collar, conical	=	2611.3.
Mount diameter d_2	20 mm =	020.
Length l_1	16 mm =	016.
Cutting form Shape	square =	1.
Cutting form width a	320 =	0320.
Cutting form length b	320 =	0320.
Order No	=	2611.3.020.016.1.0320.0320

DYNAMIC STRIPPING ELEMENTS (DAE)

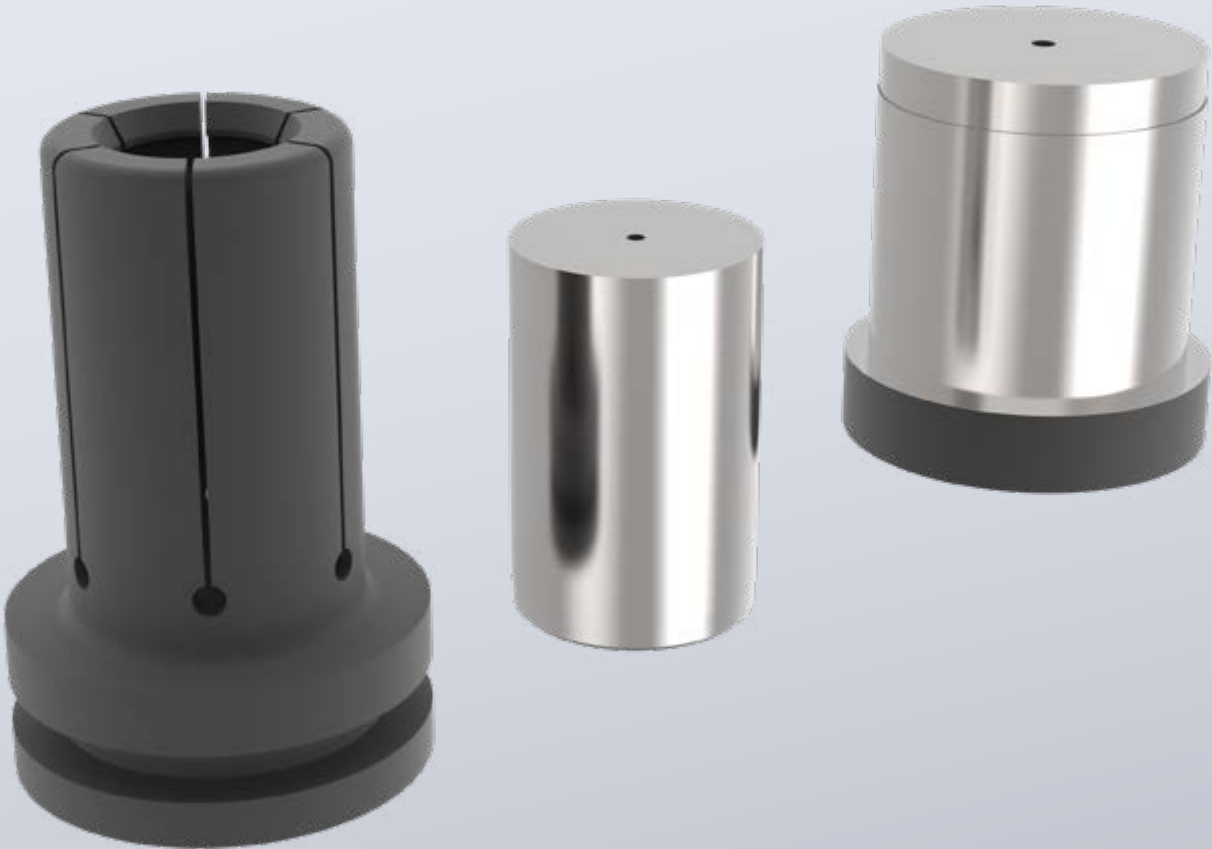

DYNAMIC STRIPPING ELEMENT (DAE)



2618.

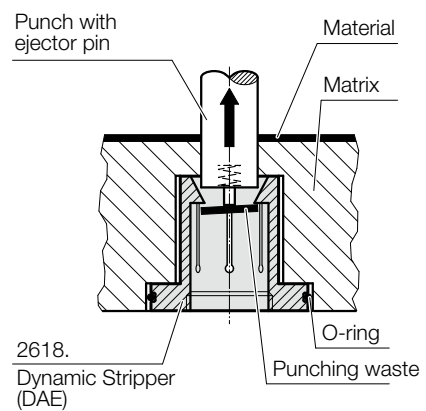
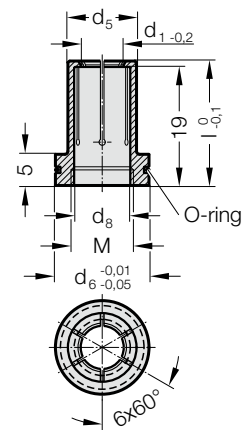

Description:

The dynamic stripper is used in blanking tools for punching operations using material up to 2 mm thick. The stripper is below the die. It is similar in shape to a segmented chuck. After the punching operation the punch enters the stripper with the punch waste still attached. The dynamic stripper opens up to receive the punch. On the return stroke the dynamic stripper strips the punch waste from the punch. The stripping element diameter d_1 is manufactured 0.2 mm smaller than the diameter p of the punch. To ensure reliable stripping the minimum entry depth into the dynamic stripper must be no less than 1 mm.

The dynamic stripper can help to protect both the tool and the product from damage and also accelerate the production rate.

Material:

Steel, hardened

Mounting example

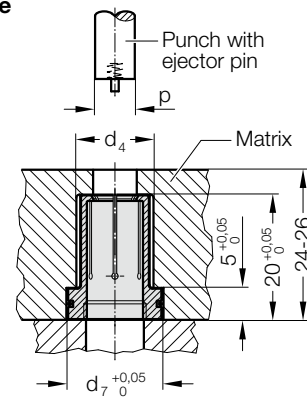

Mounting example

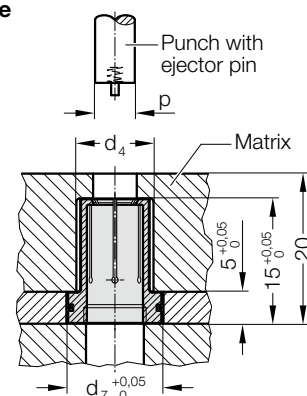

DYNAMIC STRIPPING ELEMENT (DAE)

2618. Dynamic stripping element (DAE)

Cutting punch p	DAE d ₁ Order-Ø	d ₅	d ₆	l	M	Matrix d ₄	d ₇
3.00-3.09	3	7	11	19.95	6	8	11
3.10-3.19	3.1	7	11	19.95	6	8	11
3.20-3.29	3.2	7	11	19.95	6	8	11
3.30-3.39	3.3	7	11	19.95	6	8	11
3.40-3.49	3.4	7	11	19.95	6	8	11
3.50-3.59	3.5	7	11	19.95	6	8	11
3.60-3.69	3.6	7	11	19.95	6	8	11
3.70-3.79	3.7	7	11	19.95	6	8	11
3.80-3.89	3.8	7	11	19.95	6	8	11
3.90-3.99	3.9	7	11	19.95	6	8	11
4.00-4.09	4	7	11	19.95	6	8	11
4.10-4.19	4.1	8	12	19.95	8	9	12
4.20-4.29	4.2	8	12	19.95	8	9	12
4.30-4.39	4.3	8	12	19.95	8	9	12
4.40-4.49	4.4	8	12	19.95	8	9	12
4.50-4.59	4.5	8	12	19.95	8	9	12
4.60-4.69	4.6	8	12	19.95	8	9	12
4.70-4.79	4.7	8	12	19.95	8	9	12
4.80-4.89	4.8	8	12	19.95	8	9	12
4.90-4.99	4.9	8	12	19.95	8	9	12
5.00-5.09	5	8	12	19.95	8	9	12
5.10-5.19	5.1	9	13	19.95	8	10	13
5.20-5.29	5.2	9	13	19.95	8	10	13
5.30-5.39	5.3	9	13	19.95	8	10	13
5.40-5.49	5.4	9	13	19.95	8	10	13
5.50-5.59	5.5	9	13	19.95	8	10	13
5.60-5.69	5.6	9	13	19.95	8	10	13
5.70-5.79	5.7	9	13	19.95	8	10	13
5.80-5.89	5.8	9	13	19.95	8	10	13
5.90-5.99	5.9	9	13	19.95	8	10	13
6.00-6.09	6	9	13	19.95	8	10	13
6.10-6.19	6.1	10	14	19.95	10	11	14
6.20-6.29	6.2	10	14	19.95	10	11	14
6.30-6.39	6.3	10	14	19.95	10	11	14
6.40-6.49	6.4	10	14	19.95	10	11	14
6.50-6.59	6.5	10	14	19.95	10	11	14
6.60-6.69	6.6	10	14	19.95	10	11	14
6.70-6.79	6.7	10	14	19.95	10	11	14
6.80-6.89	6.8	10	14	19.95	10	11	14
6.90-6.99	6.9	10	14	19.95	10	11	14
7.00-7.09	7	10	14	19.95	10	11	14
7.10-7.19	7.1	11	15	19.95	10	12	15
7.20-7.29	7.2	11	15	19.95	10	12	15
7.30-7.39	7.3	11	15	19.95	10	12	15
7.40-7.49	7.4	11	15	19.95	10	12	15
7.50-7.59	7.5	11	15	19.95	10	12	15
7.60-7.69	7.6	11	15	19.95	10	12	15
7.70-7.79	7.7	11	15	19.95	10	12	15
7.80-7.89	7.8	11	15	19.95	10	12	15
7.90-7.99	7.9	11	15	19.95	10	12	15
8.00-8.09	8	11	15	19.95	10	12	15

Ordering Code (example):

Dynamic stripping element (DAE)	=	2618.
Outer diameter d ₅	9 mm =	09.
Order length BL	20 mm =	020.
Order diameter d ₁	5.5 mm =	0550
Order No	=	2618. 09. 020. 0550

MATRIXES FOR DYNAMIC STRIPPER (DAE) - ORDERING CODE (EXAMPLE)

Note:

See table for standard dimensions

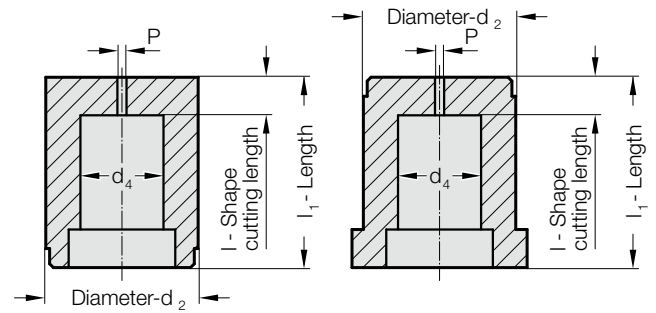
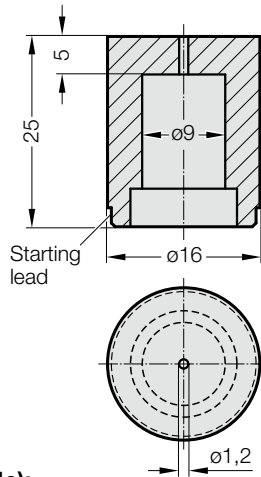

Ordering Code (example):

2618.06.6E4.09

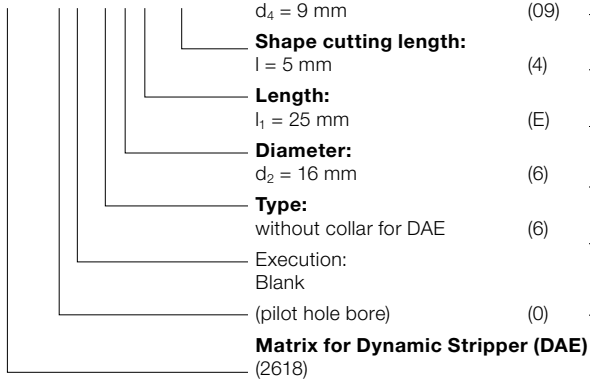

(09)	$d_4 = 9 \text{ mm}$	Shape cutting length: l	Order No
(4)		5	= 4
(E)		Length: l_1	Order Code character
(6)		25	= E
(6)		Diameter: d_2	Order No
(6)		13	= 5
(6)		16	= 6
(6)		20	= 7
(6)		Type:	Order No
(6)		without collar for DAE	= 6
(6)		with collar for DAE	= 7
(0)		Execution:	Order No
(0)		blank (pilot hole bore)	= 0

Matrixes for Dynamic Stripper (DAE)

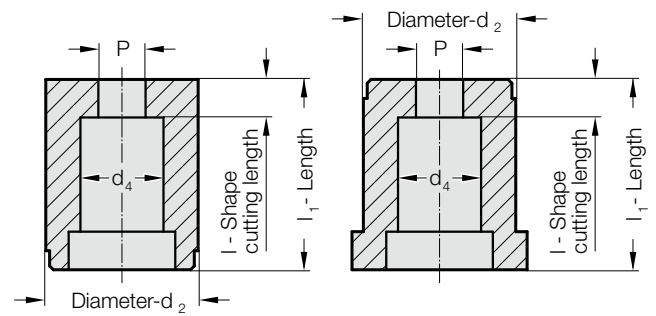
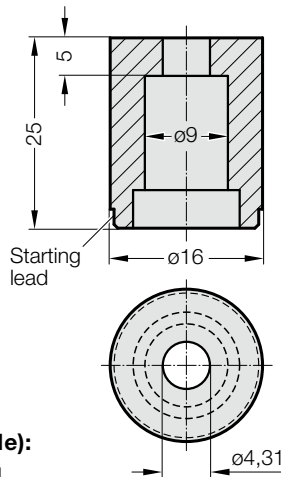

Ordering Code (example):

2618.16.6E4.0431

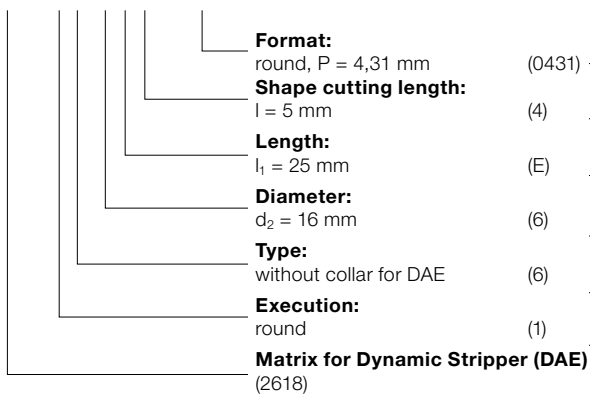

(0431)		Format: round, P = 4,31 mm	
(4)		Shape cutting length: l	Order No
(E)		5	= 4
(6)		Length: l_1	Order Code character
(6)		25	= E
(6)		Diameter: d_2	Order No
(6)		13	= 5
(6)		16	= 6
(6)		20	= 7
(6)		Type:	Order No
(6)		without collar for DAE	= 6
(6)		with collar for DAE	= 7
(1)		Execution:	Order No
(1)		round	= 1

Matrixes for Dynamic Stripper (DAE)

MATRIX WITHOUT COLLAR FOR DYNAMIC STRIPPER (DAE), BLANK

2618.06.

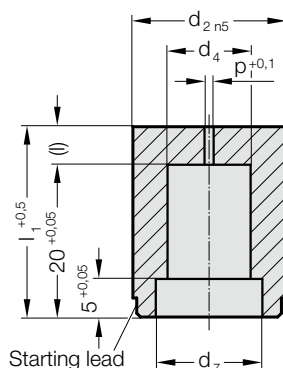

2618.06. Matrix without collar for dynamic stripper (DAE), blank

d ₂ / Order No	d ₄	d ₇	p	l / (Order No)	l ₁ / (Order Code character)
13 / (5)	8	11	1.2	5 / (4)	25 / (E)
16 / (6)	9	12	1.2	5 / (4)	25 / (E)
16 / (6)	10	13	1.5	5 / (4)	25 / (E)
20 / (7)	11	14	1.5	5 / (4)	25 / (E)
20 / (7)	12	15	1.5	5 / (4)	25 / (E)

Ordering Code (example):

2618.06.6E4.09

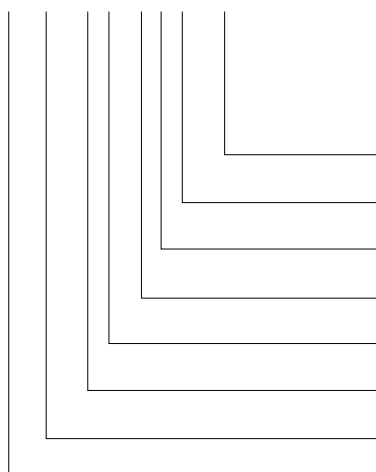

- Diameter d₄**
9 mm = 09
- Shape cutting length: l**
5 mm = (4)
- Length: l₁**
25 mm = (E)
- Diameter d₂**
16 mm = (6)
- Type:**
without collar for DAE = (6)
- Execution:**
blank (pilot hole bore) for Dynamic Stripper (DAE) = (0)
- Matrix**
= 18
- = 26

Material:

HSS
Hardness 62 ± 2 HRC

Execution:

Diameter d₂, starting lead and face surfaces ground.
Diameter P is a bored pilot hole for wire EDM.

Note:

Order dynamic stripping element (DAE) separately.

MATRIX WITH COLLAR FOR DYNAMIC STRIPPER (DAE), BLANK



2618.07.

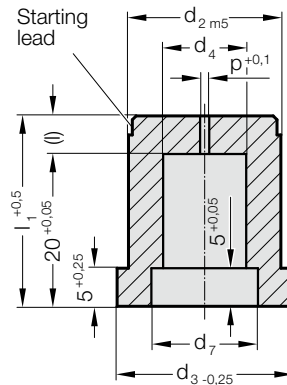

2618.07. Matrix with collar for dynamic stripper (DAE), blank

d ₂ / Order No	d ₃	d ₄	d ₇	p	l / (Order No)	l ₁ / (Order Code character)
13 / (5)	16	8	11	1.2	5 / (4)	25 / (E)
16 / (6)	19	9	12	1.2	5 / (4)	25 / (E)
16 / (6)	19	10	13	1.5	5 / (4)	25 / (E)
20 / (7)	23	11	14	1.5	5 / (4)	25 / (E)
20 / (7)	23	12	15	1.5	5 / (4)	25 / (E)

Material:

HSS
Hardness 62 ± 2 HRC

Execution:

Diameter d₂, starting lead and face surfaces ground.
Diameter P is a bored pilot hole for wire EDM.

Note:

Order dynamic stripping element (DAE) separately.

Ordering Code (example):

2618.07.6E4.09

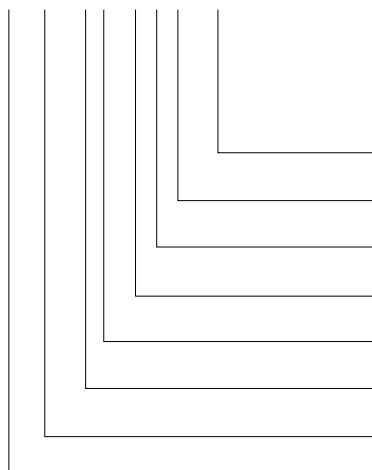

Diameter d₄

9 mm

Shape cutting length: l

5 mm

Length: l₁

25 mm

Diameter d₂

16 mm

Type:

with collar for DAE

Execution:

blank (pilot hole bore)
for Dynamic Stripper
(DAE)

Matrix

= 09

Order No

= (4)

Order Code character

= (E)

Order No

= (6)

Order No

= (7)

Order No

= (0)

= 18

= 26

MATRIX WITHOUT COLLAR FOR DYNAMIC STRIPPER (DAE), ROUND

2618.16.

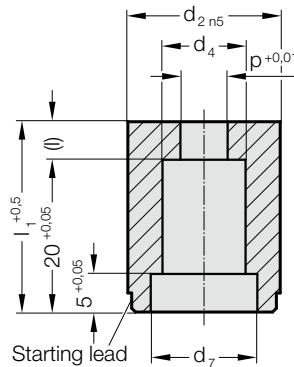

2618.16. Matrix without collar for dynamic stripper (DAE), round

d ₂ / Order No	d ₄	d ₇	l / (Order No)	l ₁ / (Order Code character)	Matrix	DAE	d ₁
					Diameter steps 0.01 P		
13 / (5)	8	11	5 / (4)	25 / (E)	3 - 4,29	7	3-4
16 / (6)	9	12	5 / (4)	25 / (E)	4,3 - 5,29	8	4,1-5
16 / (6)	10	13	5 / (4)	25 / (E)	5,3 - 6,29	9	5,1-6
20 / (7)	11	14	5 / (4)	25 / (E)	6,3 - 7,29	10	6,1-7
20 / (7)	12	15	5 / (4)	25 / (E)	7,3 - 8,29	11	7,1-8

Ordering Code (example):

2618.16.6E4.0431

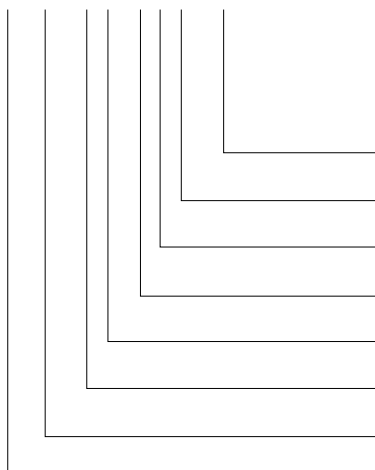

Shape: round
 P = ø4,31 mm
Shape cutting length: l
 5 mm
Length: l₁
 25 mm
Diameter d₂
 16 mm
Type:
 without collar for DAE
Execution:
 round
 for Dynamic Stripper
 (DAE)
Matrix

= 0431
Order No
 = (4)
Order Code character
 = (E)
Order No
 = (6)
Order No
 = (6)
Order No
 = (1)
 = 18
 = 26

Material:

HSS
 Hardness 62 ± 2 HRC

Execution:

Diameter d₂, starting lead and end faces ground.

Note:

Order dynamic stripping element (DAE) separately.

MATRIX WITH COLLAR FOR DYNAMIC STRIPPER (DAE), ROUND



2618.17.

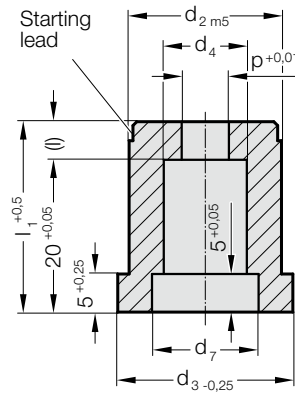

2618.17. Matrix with collar for dynamic stripper (DAE), round

d ₂ / Order No	d ₃	d ₄	d ₇	l / (Order No)	l ₁ / (Order Code character)	Matrix Diameter steps 0.01 P	DAE d ₅	d ₁ Gradation 0.1
13 / (5)	16	8	11	5 / (4)	25 / (E)	3 - 4,29	7	3-4
16 / (6)	19	9	12	5 / (4)	25 / (E)	4,3 - 5,29	8	4,1-5
16 / (6)	19	10	13	5 / (4)	25 / (E)	5,3 - 6,29	9	5,1-6
20 / (7)	23	11	14	5 / (4)	25 / (E)	6,3 - 7,29	10	6,1-7
20 / (7)	23	12	15	5 / (4)	25 / (E)	7,3 - 8,29	11	7,1-8

Material:

HSS
Hardness 62 ± 2 HRC

Execution:

Diameter d₂, starting lead and end faces ground.

Note:

Order dynamic stripping element (DAE) separately.

Ordering Code (example):

2618.17.6E4.0431

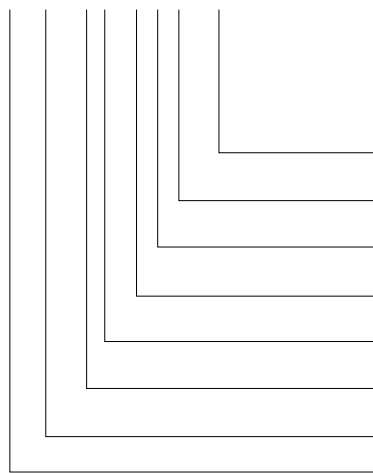

Shape: round
P = ø4,31 mm
Shape cutting length: l
5 mm
Length: l₁
25 mm
Diameter d₂
16 mm
Type:
with collar for DAE
Execution:
round
for Dynamic Stripper
(DAE)
Matrix

= 0431
Order No
= (4)
Order Code character
= (E)
Order No
= (6)
Order No
= (7)
Order No
= (1)
= 18
= 26

STANDARDISED SPECIAL SHAPES

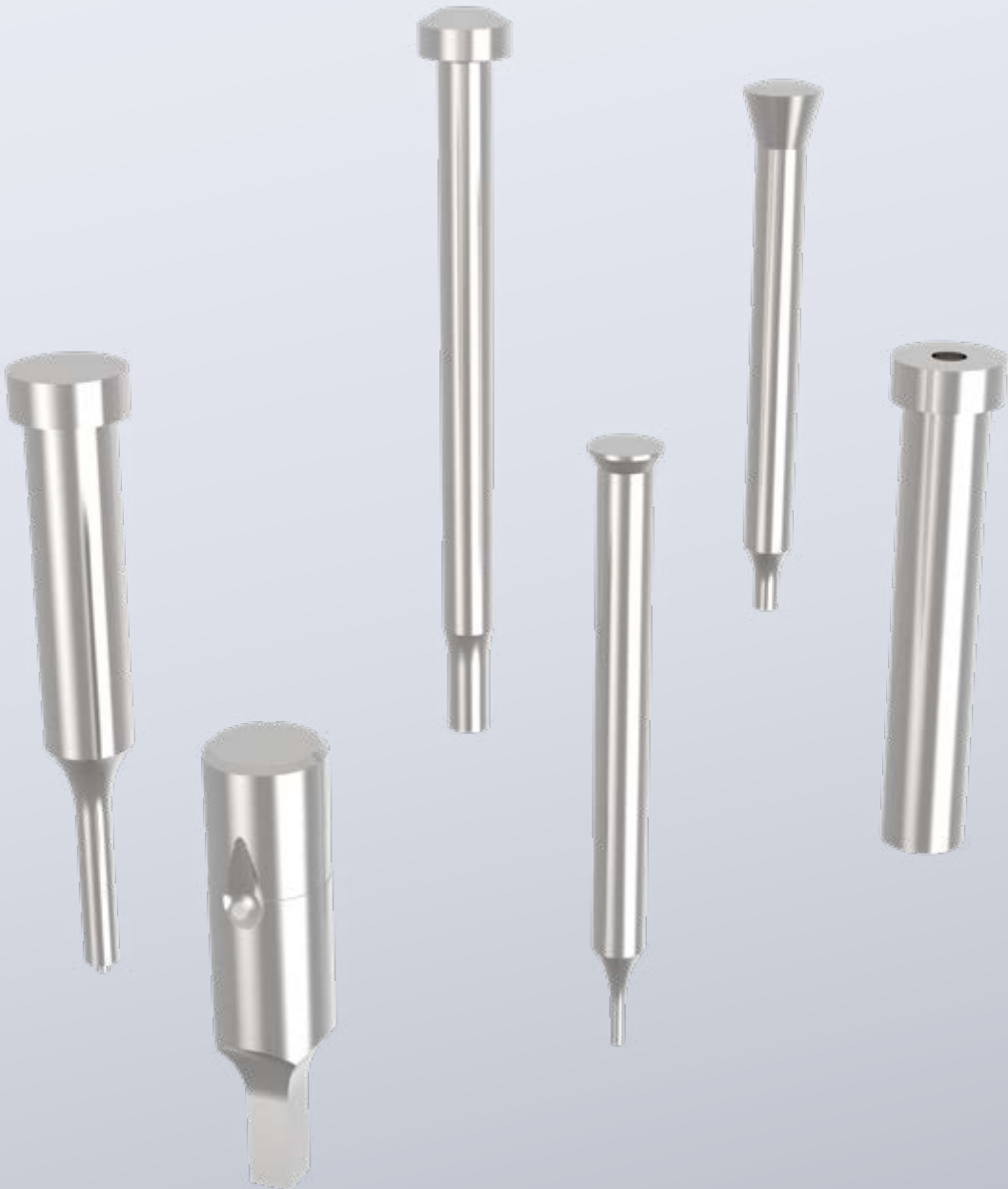

PUNCH/CUTTING BUSHINGS, STANDARDISED SPECIAL FORMS - EXAMPLE ORDERS

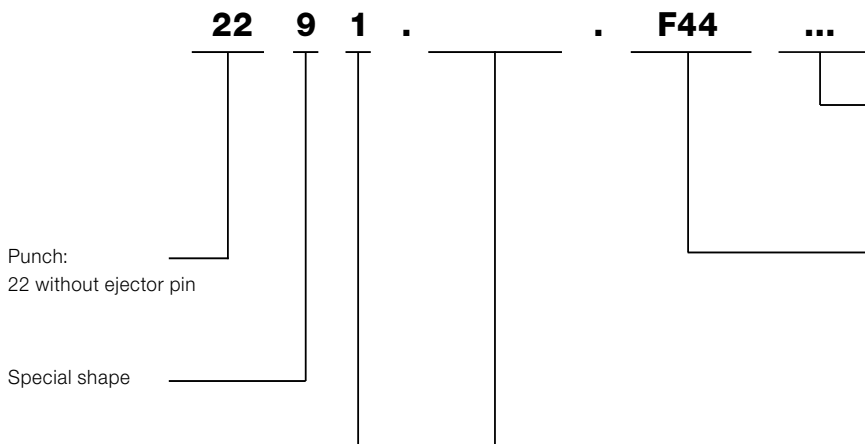

Attention!
All the parameters must be given for special shapes!

Punch:
22 without ejector pin

Special shape

Special shape F 44

Type:	Order No
ISO	= 1
ball-lock, light duty	= 2
ball-lock, heavy duty	= 3
ball-lock, larger cutting edge,= 4 light duty	
ball-lock, larger cutting edge,= 5 heavy duty	

You will find diameters and lengths on the pages of punches you have selected.

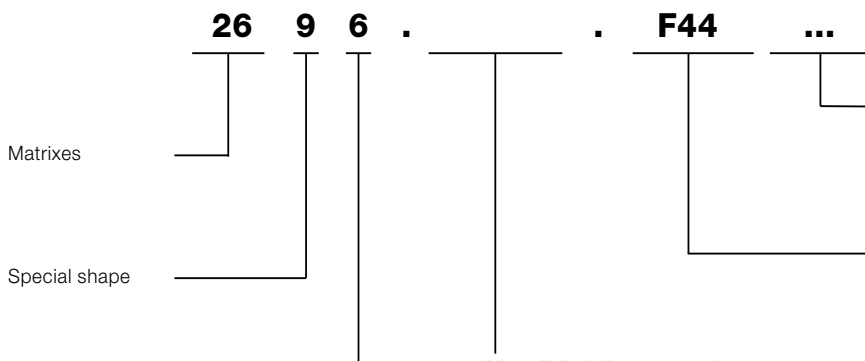
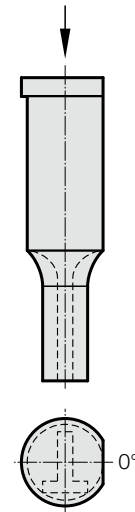

Attention!
All the parameters must be given for special shapes!

Matrixes

Special shape

Special shape F 44

Type:	Order No
Automotive standard	= 5
without shoulder ISO 8977	= 6
with shoulder ISO 8977	= 7

You will find diameters and lengths on the pages of cutting bushes you have selected.

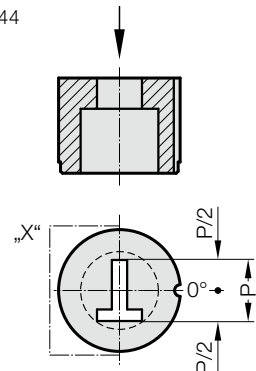

Cutting gap (a)

Roundings with the corresponding sharp corners reduce the cutting gap per side (a). If the cutting gap is 0.04 mm (a) or less, FIBRO will round the sharp edges if the cutting punch and the matrixes are ordered together. This reduces the installation time and the risk of an edge breaking during operation.

Note:

- (1) and (2) - roundings and sharp edges
- (1) rounding on the cutting punch of max. R0.2, corresponds to a sharp edge on the matrix
- (2) rounding on the cutting matrix of max. R0.2, corresponds to a sharp edge on the punch

View „X“

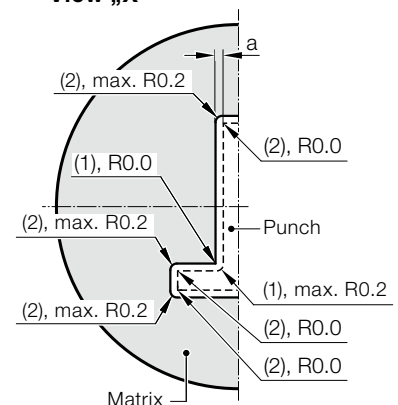

STANDARDISED SPECIAL SHAPES

90°

Round, flattened

F10

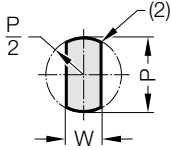

F11

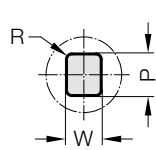

Key-hole shapes

F13

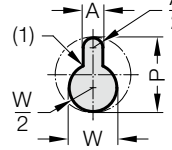

F53

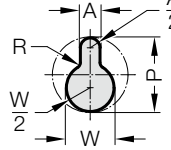

F54

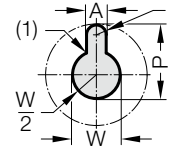

F55

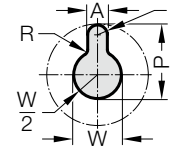

F33

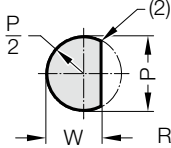

F52

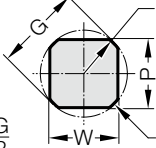

F14

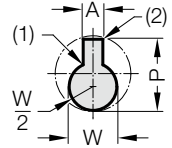

F56

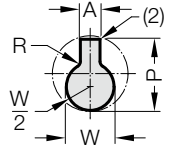

F57

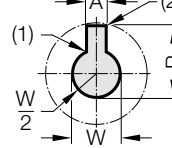

F58

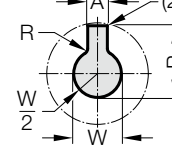

Various

F41

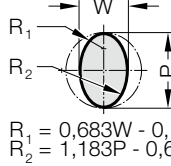

$$R_1 = 0,683W - 0,183P$$

$$R_2 = 1,183P - 0,683W$$

F93

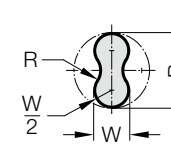

F64

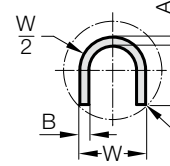

F65

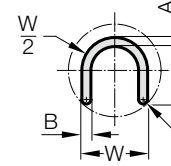

F27

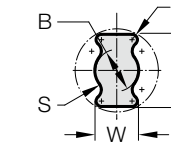

F28

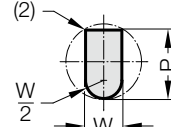

F29

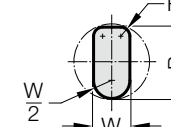

F16

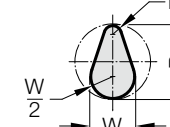

F34

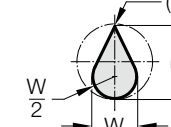

180° Triangles, trapezes

F22

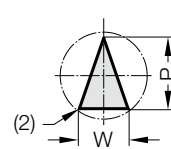

F23

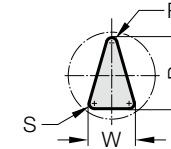

F24

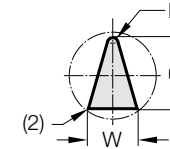

F25

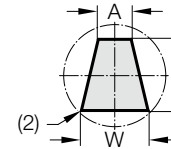

F26

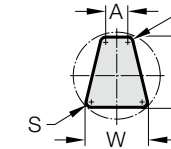

Key-hole

F30

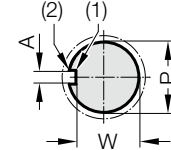

F31

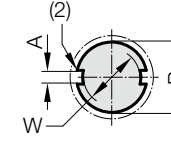

F32

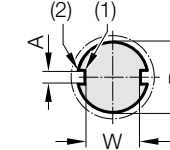

F61

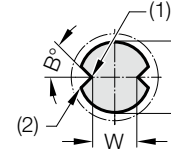

F62

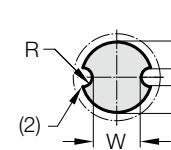

Polygons

F12

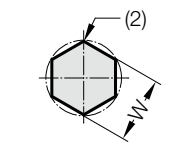

F85

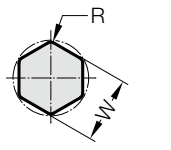

F35

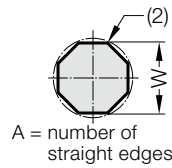

A = number of straight edges

F86

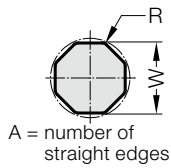

A = number of straight edges

F36

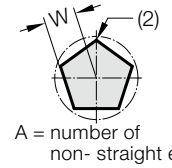

A = number of non-straight edges

F87

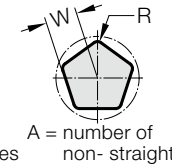

A = number of non-straight edges

F88

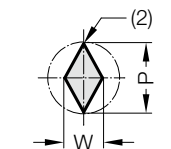

F89

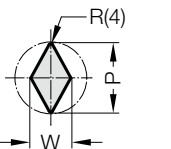

F37

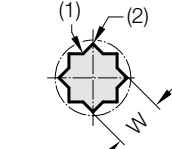

F38

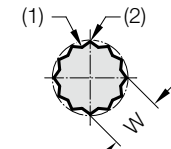

F39

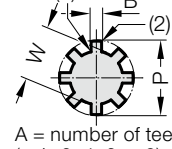

A = number of teeth (only 3, 4, 6 or 8)

F90

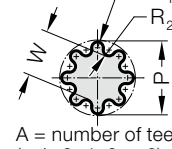

A = number of teeth (only 3, 4, 6 or 8)

270°

0°

PUNCH/CUTTING BUSHINGS, STANDARDISED SPECIAL FORMS - EXAMPLE ORDERS

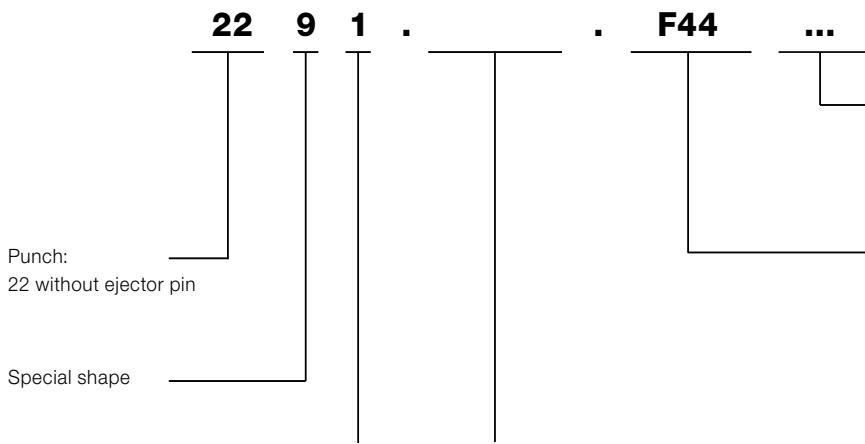

Attention!
All the parameters must be given for special shapes!

Punch:
22 without ejector pin

Special shape

Special shape F 44

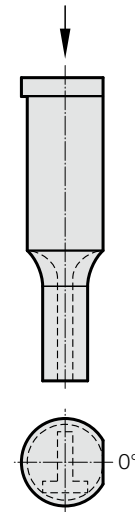

Type:	Order No
ISO	= 1
ball-lock, light duty	= 2
ball-lock, heavy duty	= 3
ball-lock, larger cutting edge,= 4 light duty	
ball-lock, larger cutting edge,= 5 heavy duty	

You will find diameters and lengths on the pages of punches you have selected.

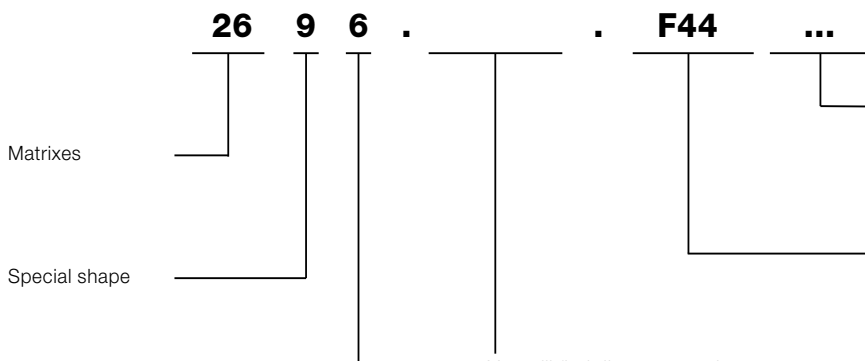

Attention!
All the parameters must be given for special shapes!

Matrixes

Special shape

Special shape F 44

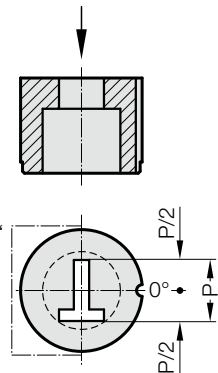

Type:	Order No
Automotive standard	= 5
without shoulder ISO 8977	= 6
with shoulder ISO 8977	= 7

You will find diameters and lengths on the pages of cutting bushes you have selected.

Cutting gap (a)

Roundings with the corresponding sharp corners reduce the cutting gap per side (a). If the cutting gap is 0.04 mm (a) or less, FIBRO will round the sharp edges if the cutting punch and the matrixes are ordered together. This reduces the installation time and the risk of an edge breaking during operation.

Note:

- (1) and (2) - roundings and sharp edges
- (1) rounding on the cutting punch of max. R0.2, corresponds to a sharp edge on the matrix
- (2) rounding on the cutting matrix of max. R0.2, corresponds to a sharp edge on the punch

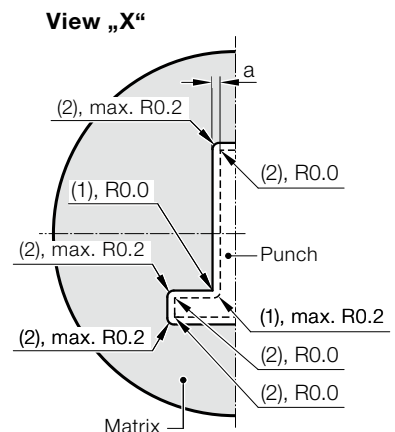

STANDARDISED SPECIAL SHAPES

90°

Multi key-hole shapes

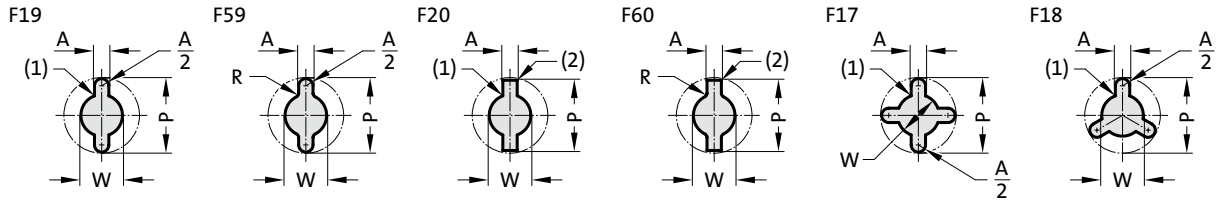

Double T-shapes

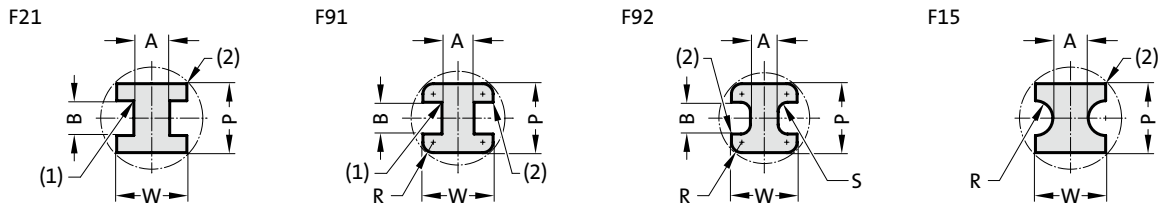

Simple T-shapes

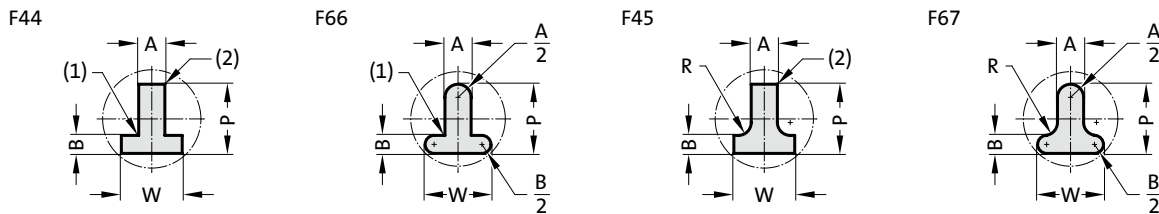

L-shapes

180°

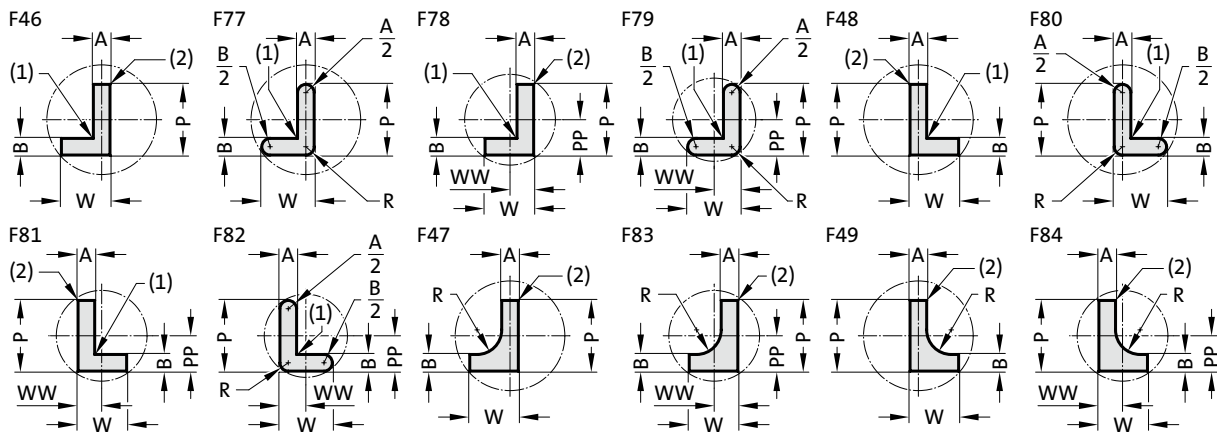

0°

U-shapes

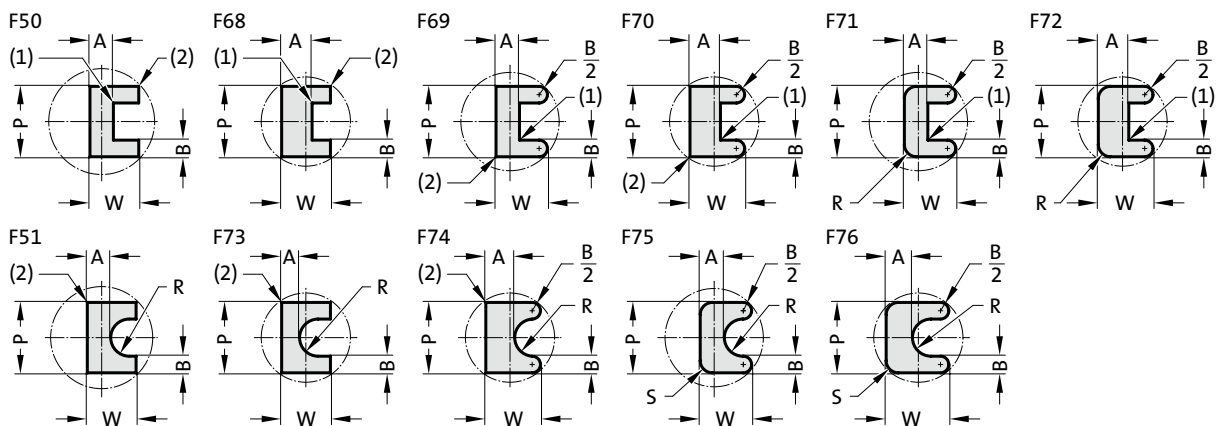

270°

PUNCHING AND EMBOSSING UNIT

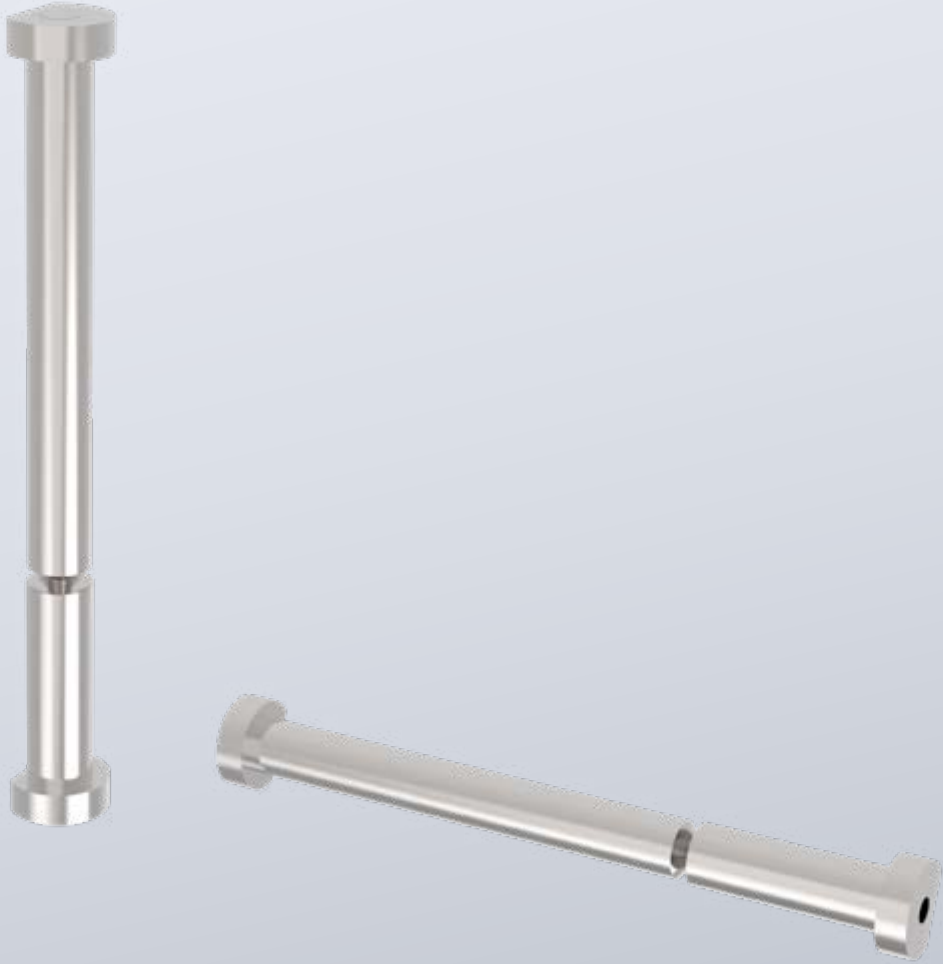

PUNCHING AND EMBOSING UNIT WITH MATRIX FOR PUNCHED HOLES AND SELF TAPPING SCREWS



Material:

HSS

Execution:

The punching and embossing unit with matrix consists of:

1 x embossing die

1 x punch die

1 x matrix

Sheet metal thickness:

max. 0,6 mm = 2282.01.035/039

max. 0,8 mm = 2282.01.042

max. 0,9 mm = 2282.01.048

max. 1,0 mm = 2282.01.055/063

2282.01. Punching and embossing unit with matrix for punched holes and self tapping screws

Order No	Nominal-Ø = Thread size	d ₁	d ₂	d _{3h6}	d _{4k6}	d _{5h6}	d ₆	d ₇	d _{8h6}	d _{9k6}	l ₁	l ₂	l ₃	l ₄	l ₅
2282.01.035	B 3,5	2.75	3.2	7.5	3.75	2.7	2.7	3.1	7.5	3.75	31.3	28	74.5	71.5	60
2282.01.039	B 3,9	3.05	3.4	7.5	3.75	3	3	3.6	7.5	3.75	31.3	28	74.5	71.5	60
2282.01.042	B 4,2	3.15	3.5	8.5	4.25	3.1	3.1	3.7	8	4	31.3	28	74.5	71.5	60
2282.01.048	B 4,8	3.85	4.2	9	4.5	3.8	3.8	4.5	8	4	31.3	28	74.5	71.5	60
2282.01.055	B 5,5	4.35	4.8	9	4.5	4.3	4.3	5	8	4	31.3	28	74.5	71.5	60
2282.01.063	B 6,3	4.85	5.3	10.5	5.25	4.8	4.8	5.5	10	5	31.3	28	74.5	71.5	60

2282.01.

2282.01.xxx.1 Embossing die

2282.01.xxx.2 Punch die

2282.01.xxx.3 Bottom die

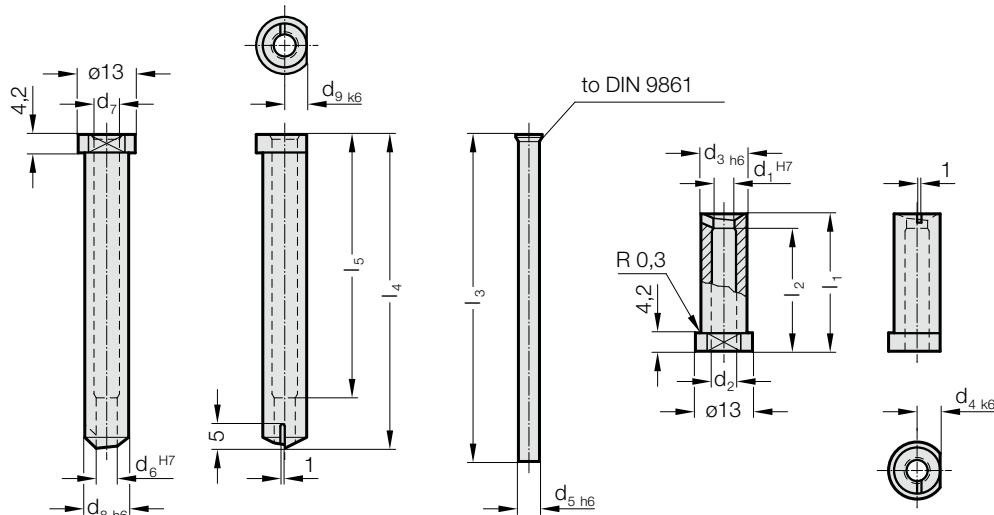

Example of application:

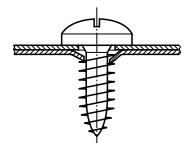

TRIANGLE RETAINERS FOR BALL-LOCK PUNCHES

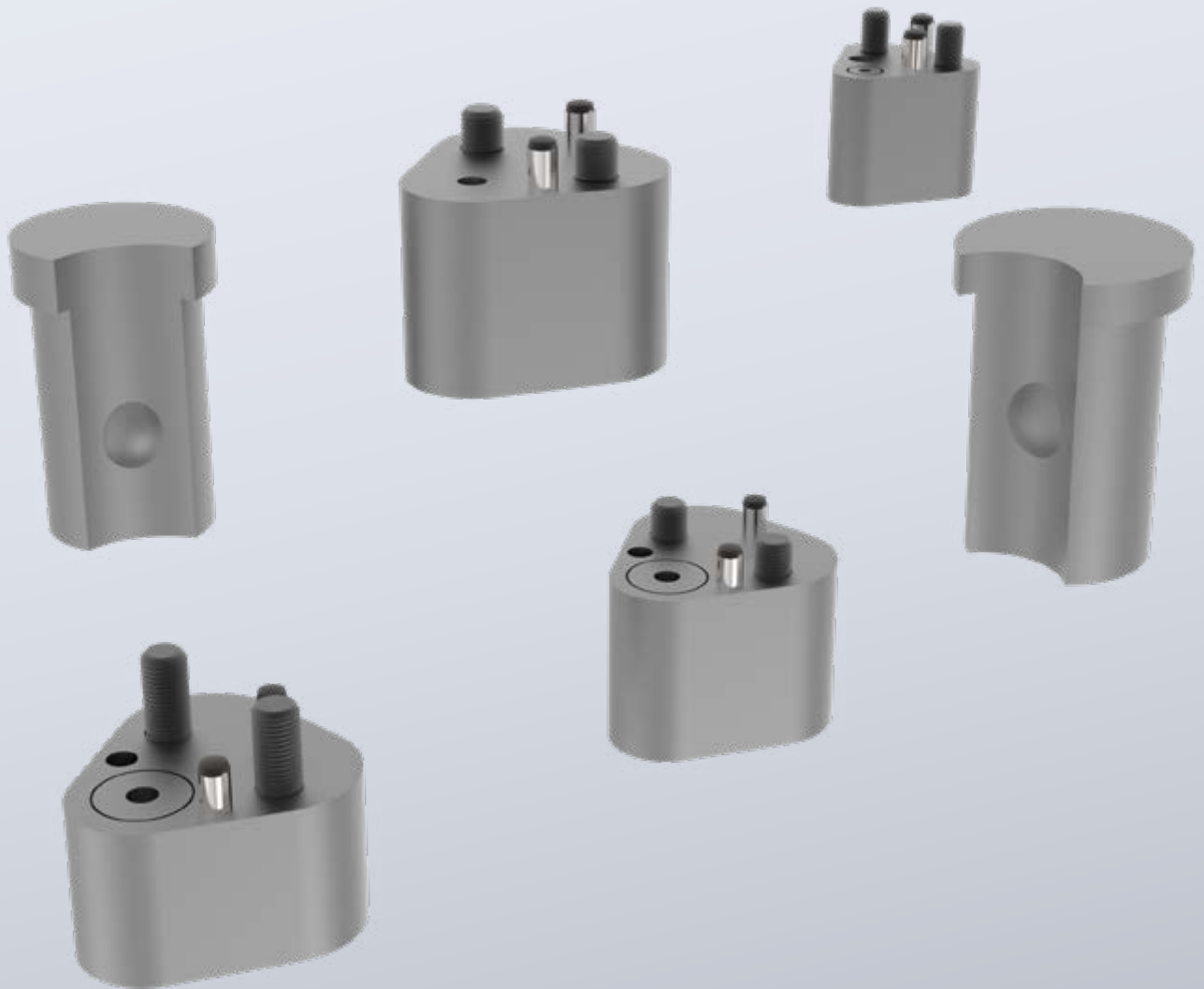

TRIANGLE RETAINER FOR BALL-LOCK PUNCHES, LIGHT DUTY

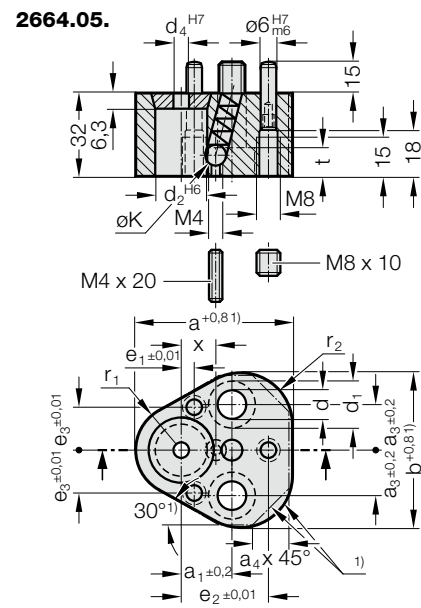

Execution:

Version for metal thicknesses up to 3 mm. The punch locating hole d_2 is manufactured to a tolerance of ± 0.01 mm relative to the 6 stud holes H7. This ensures the interchangeability of the locating plate with other polygon versions.

Note:

Special punch retainers available to order.

1) Contours may vary. Maximum dimensions are specified in the table.

2664.05. Triangle retainer for ball-lock punches, light duty

Order No	d	d ₁	d ₂	d ₄	a	a ₁	a ₃	a ₄	b	e ₁	e ₂	e ₃	ØK	t	r ₁	r ₂	x
2664.05.10	9	15	10	6	44.5	19	11.1	10	43.7	7.5	26.925	9	8	9	9.5	12	8.2
2664.05.13	9	15	13	6	50.8	19	14.3	12	50	6.5	29.97	12	8	9	12.7	15.2	9.5
2664.05.16	9	15	16	6	54	19	15.9	13	53.2	6	31.75	13.5	8	9	14.3	16.8	11.2
2664.05.20	11	18	20	6	60.3	19	17.5	14	59.5	5	33.53	16.5	8	11	17.5	20	13.2
2664.05.25	13.5	20	25	6	69.9	23.8	19.8	16	69.1	7	40.64	22	8	13.5	22.2	24.7	15.7
2664.05.32	13.5	20	32	6	69.9	23.8	19.8	16	69.1	7	40.64	22	8	13.5	22.2	24.7	19.25
2664.05.38	13.5	20	38	6	77.4	27	24	18	76.6	10	43.993	26	8	13.5	26	28.5	22.25

TRIANGLE RETAINER FOR BALL-LOCK PUNCHES, HEAVY DUTY

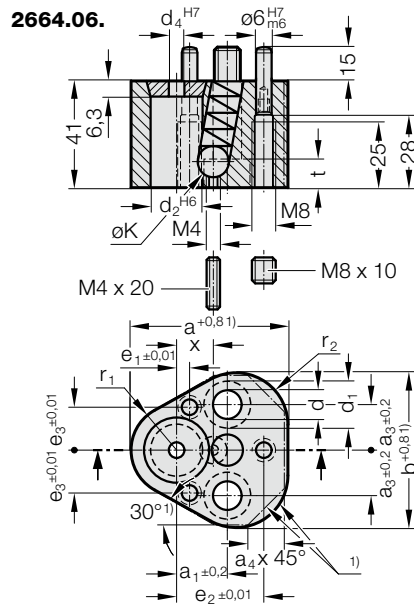

Execution:

Version for metal thicknesses ≥ 3 mm/max. 6 mm. The punch locating hole d_2 is manufactured to a tolerance of ± 0.01 mm relative to the 6 stud holes H7. This ensures the interchangeability of the locating plate with other polygon versions.

Note:

Special punch retainers available to order.

1) Contours may vary. Maximum dimensions are specified in the table.

2664.06. Triangle retainer for ball-lock punches, heavy duty

Order No	d	d ₁	d ₂	d ₄	a	a ₁	a ₃	a ₄	b	e ₁	e ₂	e ₃	ØK	t	r ₁	r ₂	x
2664.06.10	9	15	10	6	44.5	19.05	11.12	10	43.7	7.5	26.92	9	10	9	9.5	12	9.8
2664.06.13	9	15	13	6	50.8	19.05	14.27	12	50	6.5	29.97	12	12	9	12.7	15.2	11.3
2664.06.16	9	15	16	6	54	19.05	15.87	13	53.2	6	31.75	13.5	12	9	13.3	16.8	12.8
2664.06.20	11	18	20	6	60.3	19.05	17.47	14	59.5	5	33.53	16.5	12	11	17.5	20	14.8
2664.06.25	13.5	20	25	6	69.9	23.82	19.84	16	69.1	7	40.64	22	12	13	22.2	24.7	17.3
2664.06.32	13.5	20	32	6	69.9	23.82	19.84	16	69.1	7	40.64	22	12	13	22.2	24.7	20.8
2664.06.40	13.5	20	40	6	77.4	27	24	18	76.6	10	43.99	26	12	13	26	28.5	24.8

TRIANGLE RETAINER FOR BALL-LOCK PUNCHES, LIGHT DUTY

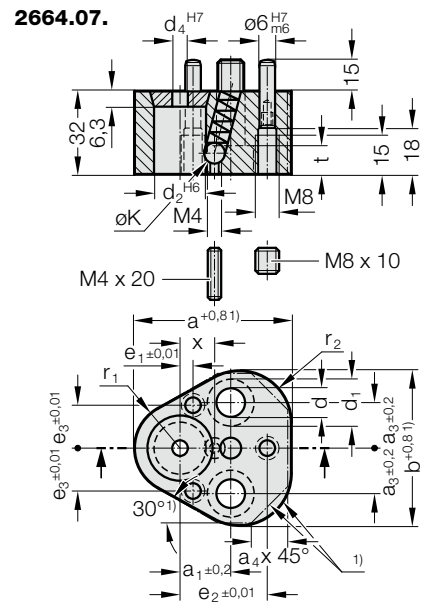

Execution:

Version for metal thicknesses up to 3 mm. The punch locating hole d_2 is manufactured to a tolerance of ± 0.01 mm relative to the 6 stud holes H7. This ensures the interchangeability of the locating plate with other polygon versions.

Note:

Special punch retainers available to order.

1) Contours may vary. Maximum dimensions are specified in the table.

2664.07. Triangle retainer for ball-lock punches, light duty

Order No	d	d ₁	d ₂	d ₄	a	a ₁	a ₃	a ₄	b	e ₁	e ₂	e ₃	ØK	t	r ₁	r ₂	x
2664.07.06	6.6	11	6	3	35	19	11.1	6	37.5	9	23	8	6	7	8	8	5.7

TRIANGLE RETAINER FOR BALL-LOCK PUNCHES, HEAVY DUTY

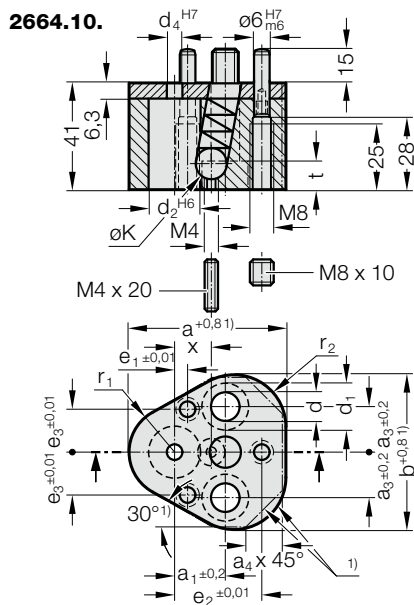

Execution:

Version for metal thicknesses ≥ 3 mm/max. 6 mm. The punch locating hole d_2 is manufactured to a tolerance of ± 0.01 mm relative to the 6 stud holes H7. This ensures the interchangeability of the locating plate with other polygon versions.

Note:



Special punch retainers available to order.
Pressure plate welded.

1) Contours may vary. Maximum dimensions are specified in the table.

2664.10. Triangle retainer for ball-lock punches, heavy duty

Order No	d	d ₁	d ₂	d ₄	a	a ₁	a ₃	a ₄	b	e ₁	e ₂	e ₃	ØK	t	r ₁	r ₂	x
2664.10.10	9	15	10	6	44.5	19	11.1	10	43.7	7.5	26.925	9	10	9	9.5	12	9.8
2664.10.13	9	15	13	6	50.8	19	14.3	12	50	6.5	29.97	12	12	9	12.7	15.2	11.3
2664.10.16	9	15	16	6	54	19	15.9	13	53.2	6	31.75	13.5	12	9	14.3	16.8	12.8
2664.10.20	11	18	20	6	60.3	19	17.5	14	59.5	5	33.53	16.5	12	11	17.5	20	14.8
2664.10.25	13.5	20	25	6	69.9	23.8	19.8	16	69.1	7	40.64	22	12	13.5	22.2	24.7	17.3
2664.10.32	13.5	20	32	6	69.9	23.8	19.8	16	69.1	7	40.64	22	12	13.5	22.2	24.7	20.8
2664.10.40	13.5	20	40	6	77.4	27	24	18	76.6	10	43.993	26	12	13	26	28.5	24.8

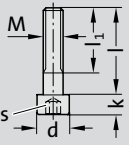
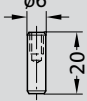
ACCESSORIES FOR RETAINERS, TRIANGULAR, FOR BALL-LOCK PUNCHES

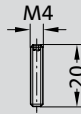
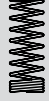
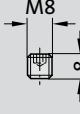
	2192.10.	236.1.	2666.04.	2192.72.	2666.06.	2192.72.	
							
Retainer	ø d ₂	Socket head cap screw	Dowel pin	Ball	Ball release pin	Spring	Pin screw
2664.05.	10	2192.10.08.035	236.1.0600.020	2666.04.008	2192.72.04.020	2666.06.008	2192.72.08.008
	13	2192.10.08.035	236.1.0600.020	2666.04.008	2192.72.04.020	2666.06.008	2192.72.08.008
	16	2192.10.08.035	236.1.0600.020	2666.04.008	2192.72.04.020	2666.06.008	2192.72.08.008
	20	2192.10.10.035	236.1.0600.020	2666.04.008	2192.72.04.020	2666.06.008	2192.72.08.008
	25	2192.10.12.035	236.1.0600.020	2666.04.008	2192.72.04.020	2666.06.008	2192.72.08.008
	32	2192.10.12.035	236.1.0600.020	2666.04.008	2192.72.04.020	2666.06.008	2192.72.08.008
	38	2192.10.12.035	236.1.0600.020	2666.04.008	2192.72.04.020	2666.06.008	2192.72.08.008
2664.06./10.	10	2192.10.08.040	236.1.0600.020	2666.04.010	2192.72.04.020	2666.06.010	2192.72.08.008
	13	2192.10.08.040	236.1.0600.020	2666.04.012	2192.72.04.020	2666.06.012	2192.72.08.008
	16	2192.10.08.040	236.1.0600.020	2666.04.012	2192.72.04.020	2666.06.012	2192.72.08.008
	20	2192.10.10.050	236.1.0600.020	2666.04.012	2192.72.04.020	2666.06.012	2192.72.08.008
	25	2192.10.12.050	236.1.0600.020	2666.04.012	2192.72.04.020	2666.06.012	2192.72.08.008
	32	2192.10.12.050	236.1.0600.020	2666.04.012	2192.72.04.020	2666.06.012	2192.72.08.008
	40	2192.10.12.050	236.1.0600.020	2666.04.012	2192.72.04.020	2666.06.012	2192.72.08.008
2664.07.	6	2192.10.06.035	236.1.0600.020	2666.04.006	2192.72.04.020	2666.06.006	2192.72.08.008

Ball release tool

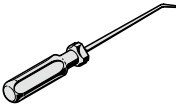
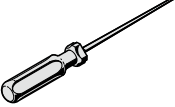
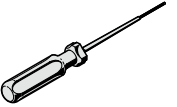
Hook shape	straight shape	straight shape with threaded tip
2666.05.01	2666.05.02	2666.05.03
		

ACCU-LOCK FIXTURE DEVICE FOR BALL-LOCK PUNCHES, LIGHT DUTY

2668.2.

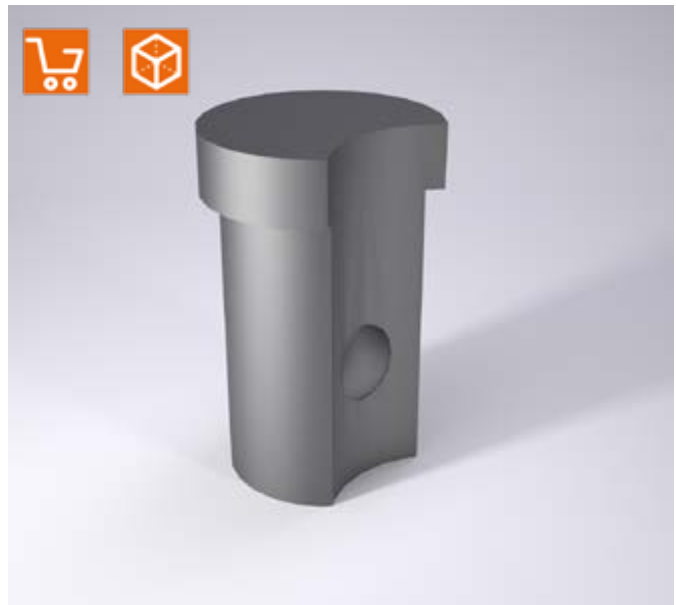
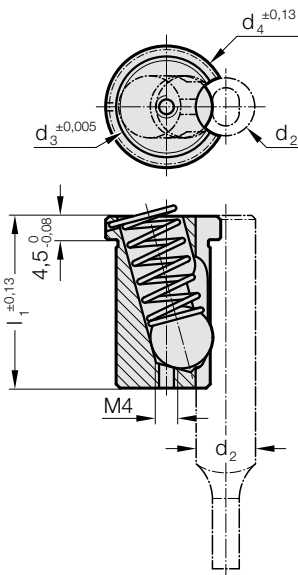

Note:

Use ball release tool 2666.05.02, straight.

Mounting example

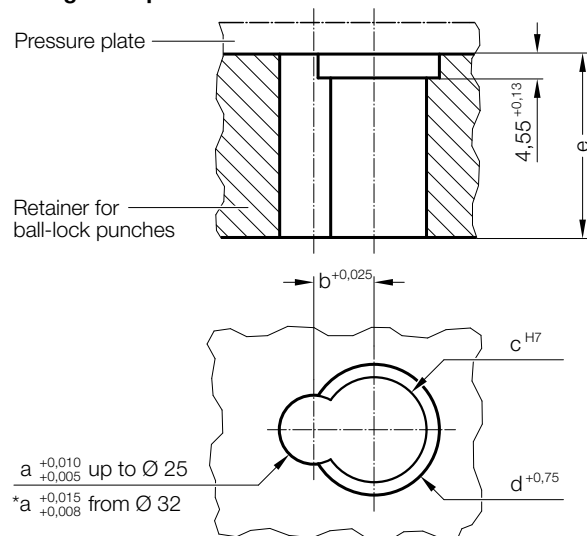

2668.2. ACCU-LOCK Fixture device for ball-lock punches, light duty

Order No	d ₂	d ₃	d ₄	l ₁	a	b	c	d	e
2668.2.06	6	12	14.6	25.7	6	6.5	12.013	15	25.7
2668.2.10	10	14	16.6	25.7	10	9	14.013	17	25.7
2668.2.13	13	14	16.6	25.7	13	10.5	14.013	17	25.7
2668.2.16	16	14	16.6	25.7	16	12	14.013	17	25.7
2668.2.20	20	16	18.6	25.7	20	14	16.013	19	25.7
2668.2.25	25	16	18.6	25.7	25	16.5	16.013	19	25.7
2668.2.32	32	16	18.6	25.7	32	20	16.013	19	25.7
2668.2.38	38	16	18.6	25.7	38	23	16.013	19	25.7

ACCU-LOCK FIXTURE DEVICE FOR BALL-LOCK PUNCHES, HEAVY DUTY



2668.3.

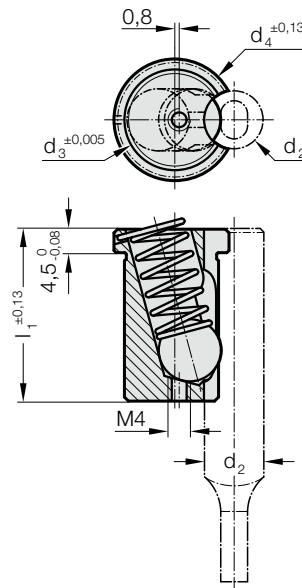

Mounting example

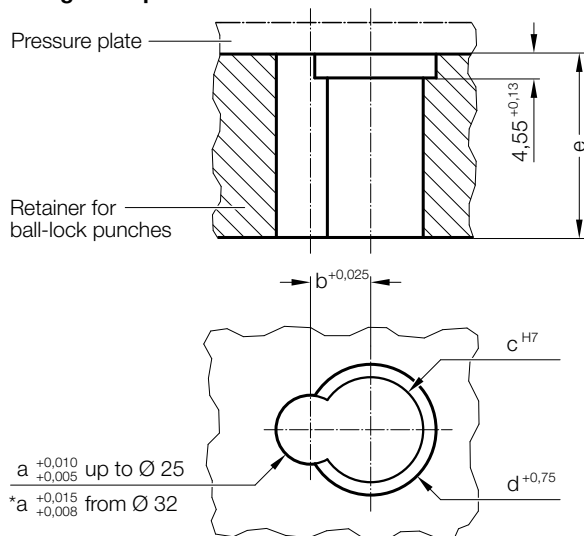

Note:

Use ball release tool 2666.05.02, straight.

2668.3. ACCU-LOCK Fixture device for ball-lock punches, heavy duty

Order No	d ₂	d ₃	d ₄	l ₁	a	b	c	d	e
2668.3.10	10	16	19.6	34.7	10	10	16.013	20	34.7
2668.3.13	13	20	24.6	34.7	13	11.5	20.013	25	34.7
2668.3.16	16	20	24.6	34.7	16	13	20.013	25	34.7
2668.3.20	20	20	24.6	34.7	20	15	20.013	25	34.7
2668.3.25	25	20	24.6	34.7	25	17.5	20.013	25	34.7
2668.3.32	32	20	24.6	34.7	32	21	20.013	25	34.7
2668.3.40	40	20	24.6	34.7	40	25	20.013	25	34.7

TRIANGLE RETAINERS FOR PUNCHES ISO 8020

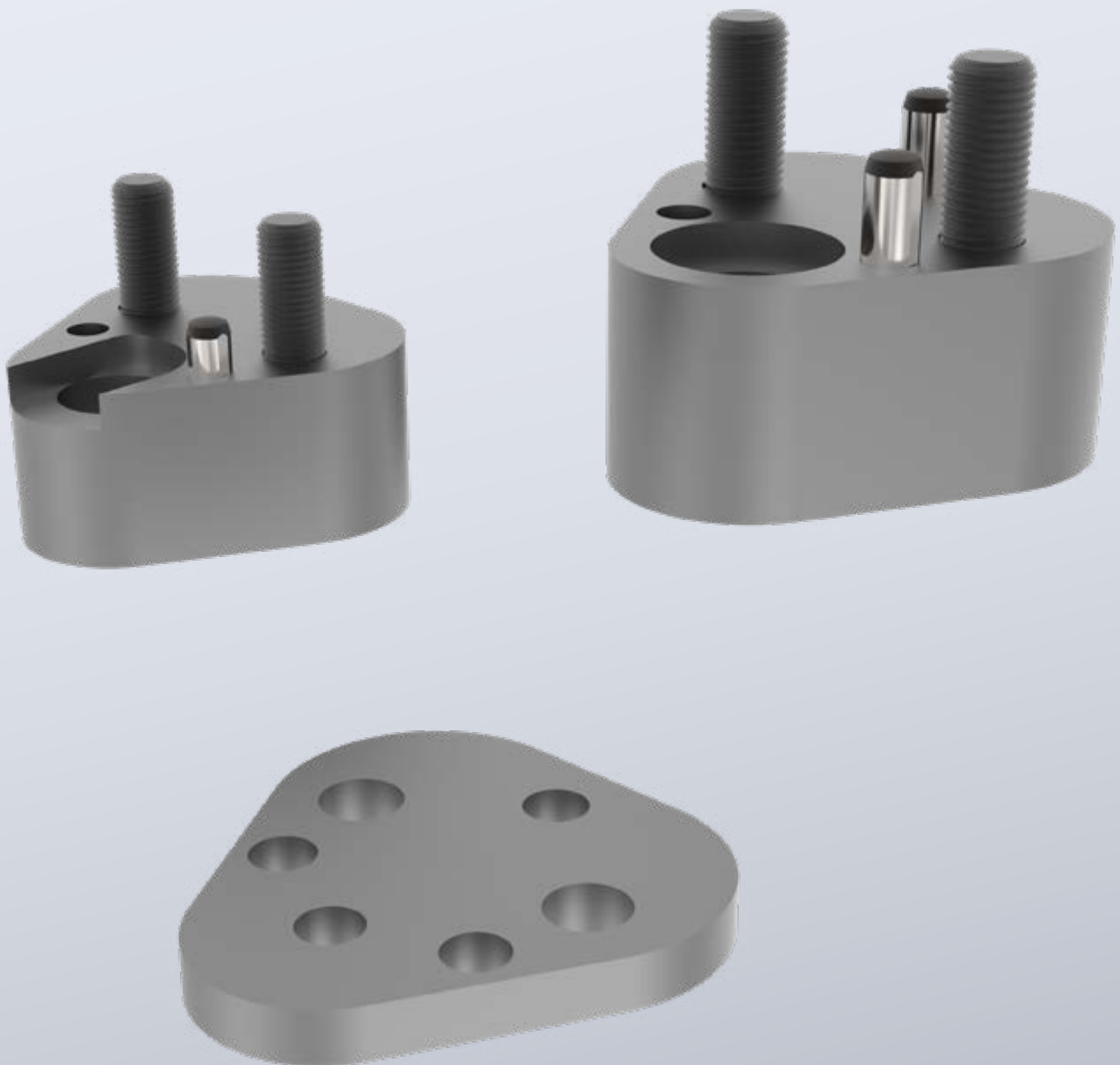

TRIANGLE RETAINER, FOR PUNCHES ISO 8020 WITHOUT ANTI-ROTATION ELEMENT

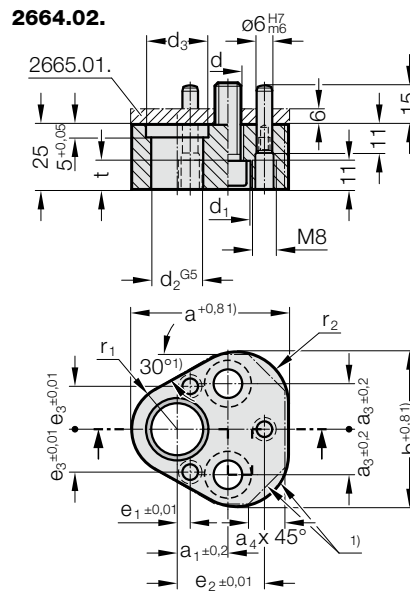

Execution:

The centres of the pinholes are the reference points for the position of the punch bore.

The dimensions e_1 , e_2 and e_3 have a tolerance of ± 0.01 mm.

The triangle ball-lock retainers are interchangeable.

Note:

Pressure plate 2665.01. to be ordered separately for the receiving punch plate.

1) Contours may vary. Maximum dimensions are specified in the table.

2664.02. Triangle retainer, for punches ISO 8020 without anti-rotation element

Order No	d	d ₁	d ₂	d ₃	a	a ₁	a ₃	a ₄	b	e ₁	e ₂	e ₃	t	r ₁	r ₂
2664.02.10	9	15	10	14	44.5	19	11.1	10	43.7	7.5	26.925	9	9	9.5	12
2664.02.13	9	15	13	17	50.8	19	14.3	12	50	6.5	29.97	12	9	12.7	15.2
2664.02.16	9	15	16	20	54	19	15.9	13	53.2	6	31.75	13.5	9	14.3	16.8
2664.02.20	11	18	20	24	60.3	19	17.5	14	59.5	5	33.53	16.5	11	17.5	20
2664.02.25	13.5	20	25	29	69.9	23.8	19.8	16	69.1	7	40.64	22	13.5	22.2	24.7
2664.02.32	13.5	20	32	36	69.9	23.8	19.8	16	69.1	7	40.64	22	13.5	22.2	24.7

TRIANGLE RETAINER, FOR PUNCHES ISO 8020 WITH ANTI-ROTATION ELEMENT

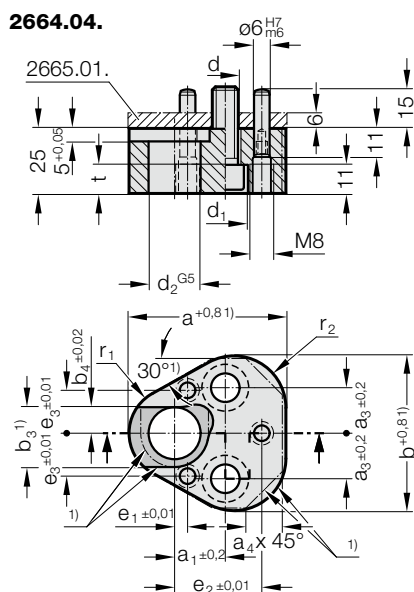

Execution:

The centres of the pinholes are the reference points for the position of the punch bore.

The dimensions e_1 , e_2 and e_3 have a tolerance of ± 0.01 mm.

The triangle ball-lock retainers are interchangeable.

Note:

Pressure plate 2665.01. to be ordered separately for the receiving punch plate.

1) Contours may vary. Maximum dimensions are specified in the table.

2664.04. Triangle retainer, for punches ISO 8020 with anti-rotation element

Order No	d	d ₁	d ₂	a	a ₁	a ₃	a ₄	b	b ₃	b ₄	e ₁	e ₂	e ₃	t	r ₁	r ₂
2664.04.10	9	15	10	44.5	19	11.1	10	43.7	12	5	7.5	26.925	9	9	9.5	12
2664.04.13	9	15	13	50.8	19	14.3	12	50	15	6.5	6.5	29.97	12	9	12.7	15.2
2664.04.16	9	15	16	54	19	15.9	13	53.2	18	8	6	31.75	13.5	9	14.3	16.8
2664.04.20	11	18	20	60.3	19	17.5	14	59.5	22	10	5	33.53	16.5	11	17.5	20
2664.04.25	13.5	20	25	69.9	23.8	19.8	16	69.1	27	12.5	7	40.64	22	13.5	22.2	24.7
2664.04.32	13.5	20	32	69.9	23.8	19.8	16	69.1	34	16	7	40.64	22	13.5	22.2	24.7

ACCESSORIES FOR RETAINERS, TRIANGULAR, FOR PUNCHES TO ISO 8020

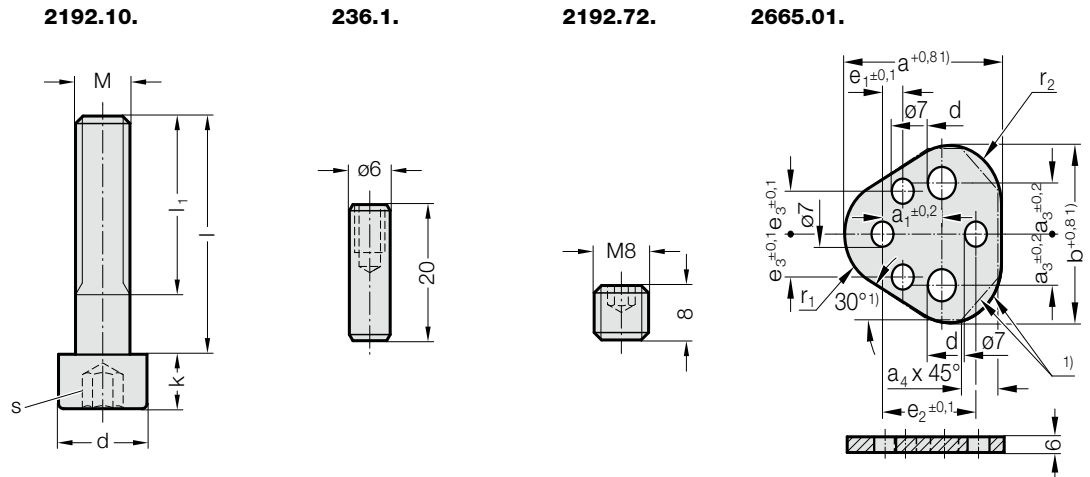

Retainer	$\varnothing d_2$	Socket head cap screw	Dowel pin	Pin screw	Pressure plate
2664.02./04.	10	2192.10.08.035	236.1.0600.020	2192.72.08.008	2665.01.10
	13	2192.10.08.035	236.1.0600.020	2192.72.08.008	2665.01.13
	16	2192.10.08.035	236.1.0600.020	2192.72.08.008	2665.01.16
	20	2192.10.10.035	236.1.0600.020	2192.72.08.008	2665.01.20
	25	2192.10.12.035	236.1.0600.020	2192.72.08.008	2665.01.25
	32	2192.10.12.035	236.1.0600.020	2192.72.08.008	2665.01.32

STRIPPERS

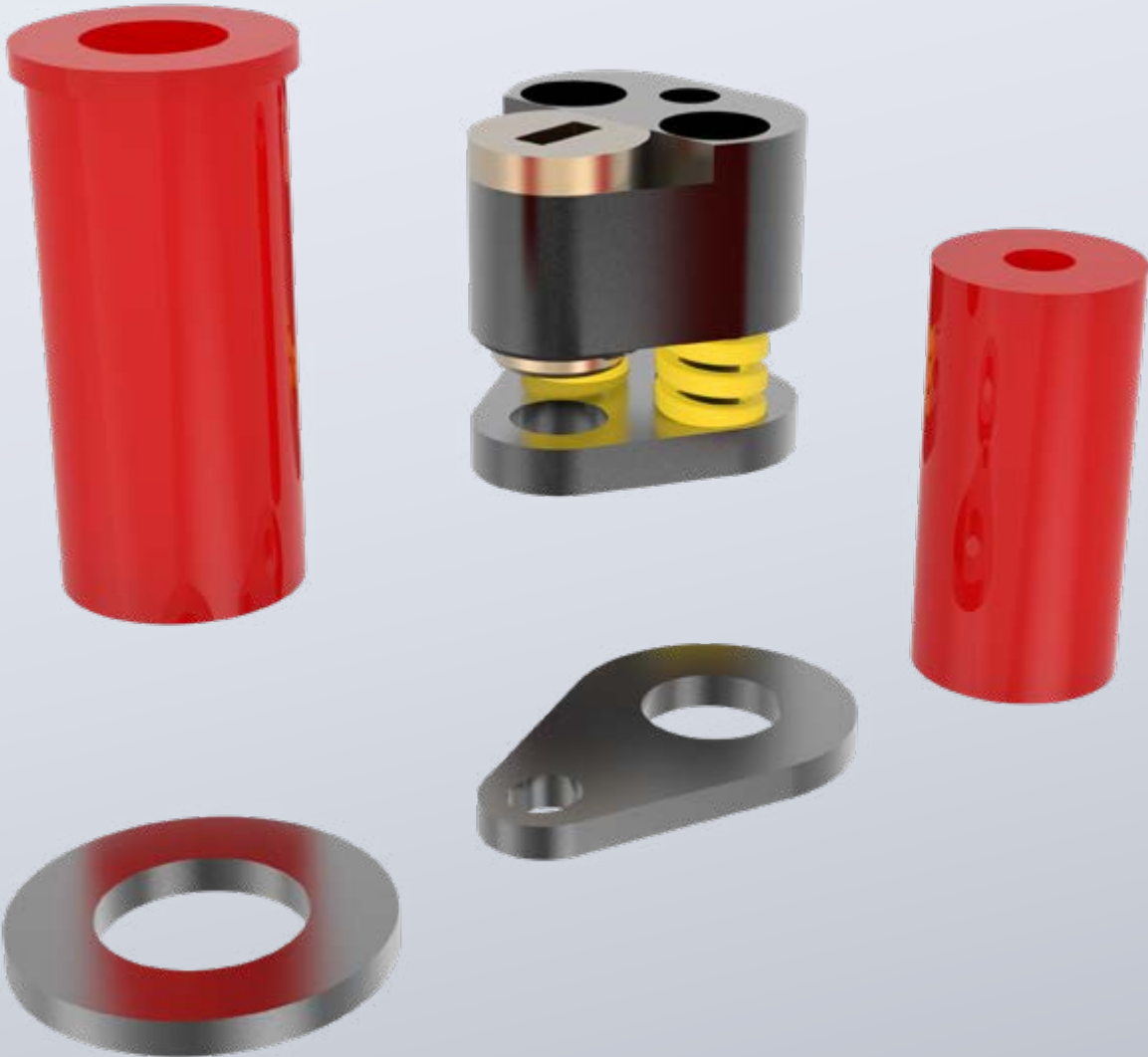

ELASTOMER STRIPPER



2431.7.

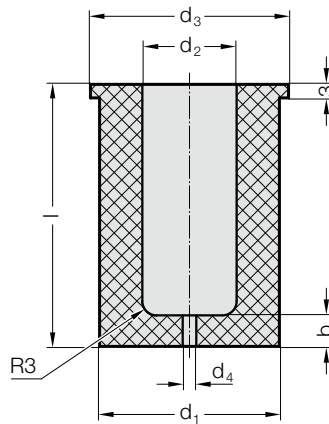

Mounting example

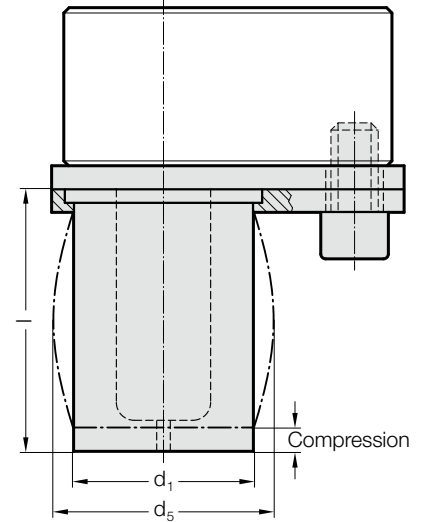

Material:

FIBROFLEX® 95 Shore A

Note:

Stripping units can be used for retainers 2664.02./04./05./06./10.

* values for the stripping force are dependent on a number of parameters (e.g. lubricant, temperature etc.) and may vary from those given here.

** max spring travel should not exceed 15% of the length

2431.7. Elastomer Stripper

d ₂	d ₁	d ₃	d ₄	d ₅ max.	b	Stripping unit length l				
						35	43	53	63	73
10	18	21	1,6	22	6	○	●	●	●	
13	23	26	3	26,5	6	○	●	●	●	●
16	28	31	3	34	6	○	●	●	●	●
20	33	36	3	38	7	○	●	●	●	●
25	40	43	3	47,6	7	○	●	●	●	●
32	50	55	3	57,9	7	○	●	●	●	●
38	60	65	3	69,6	8	○	○	○	○	○
40	60	65	3	69,6	8		●	●	●	○
						Punch lengths in use				
Ball-lock punch, light duty						63	71	80	90	100
Ball-lock punch, heavy duty						71	80	90	100	110
Precision punch ISO 8020						-	71	80	90	100
○ = Special measures upon request										

Stroke**	3mm			6mm			9mm			3mm			6mm			9mm		
	35	35	35	43	43	43	53	53	53	63	63	63	73	73	73	73	73	
d ₂	Stripping forces (N)*																	
10	1300	-	-	1060	1820	-	900	1650	-	720	1450	1860	-	-	-	-	-	
13	2100	-	-	1700	2850	-	1460	2610	-	1170	2320	2910	930	2080	2500	-	-	
16	3000	-	-	2310	3900	-	1990	3560	-	1590	3150	3980	1270	2810	3440	-	-	
20	3500	-	-	2900	4900	-	2500	4470	-	2000	3950	5000	1590	3420	4330	-	-	
25	5400	-	-	4440	7520	-	3810	6860	-	3050	6050	7680	2420	5390	6780	-	-	
32	8400	-	-	6840	11390	-	5880	10450	-	4700	9310	11640	3740	8370	10280	-	-	
38	-	-	-	9280	19740	-	8140	15890	-	6440	11570	18030	5460	8850	11680	-	-	
40	-	-	-	10100	20190	-	8650	17300	-	6890	13780	20670	6000	9800	12700	-	-	

Ordering Code (example):

Elastomer Stripper = 2431.7.

d₂ = 10 mm = 10.

l = 53 mm = 53

Order No = 2431.7.10.53

STRIPPING UNIT - PRESSURE PLATE

2667.1.

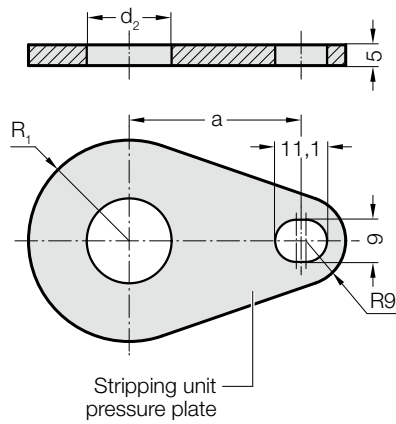

2667.1. Stripping unit - Pressure plate

Order No	d ₂	R ₁	a
2667.1.010	10	13	28
2667.1.013	13	15.5	31
2667.1.016	16	18	32.9
2667.1.020	20	20.5	34.8
2667.1.025	25	24	39.8
2667.1.032	32	31	41.3
2667.1.038	38	36	45
2667.1.040	40	36	45

Note:

Pressure plate, mounting plate and screw must all be ordered individually.

Mounting example

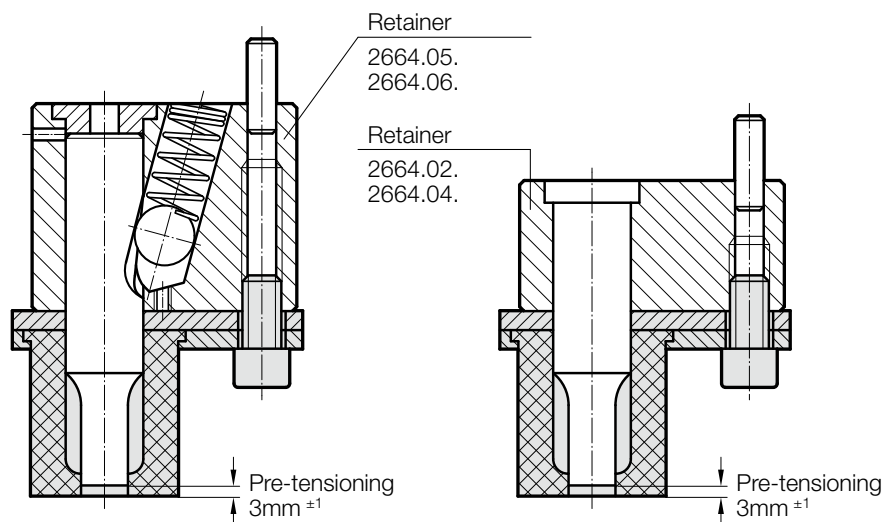

STRIPPING UNIT - MOUNTING PLATE



2667.2.

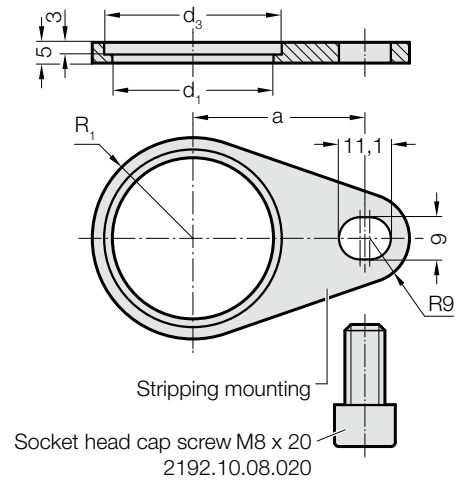

Note:

Pressure plate, mounting plate and screw must all be ordered individually.

2667.2. Stripping unit - Mounting plate

Order No	d ₂	d ₁	d ₃	R ₁	a
2667.2.010	10	19	22	13	28
2667.2.013	13	24	27	15.5	31
2667.2.016	16	29	32	18	32.9
2667.2.020	20	34	37	20.5	34.8
2667.2.025	25	41	44	24	39.8
2667.2.032	32	51	56	31	41.3
2667.2.038	38	61	66	36	45
2667.2.040	40	61	66	36	45

Mounting example

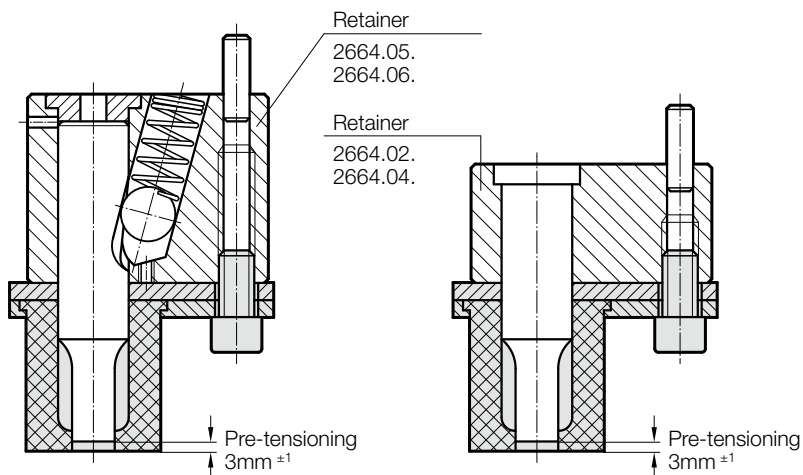

ELASTOMER STRIPPER



Mounting example

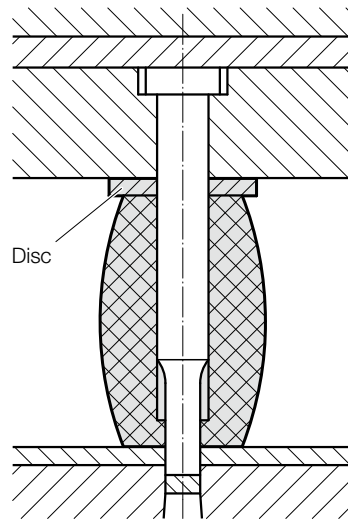

243.7.

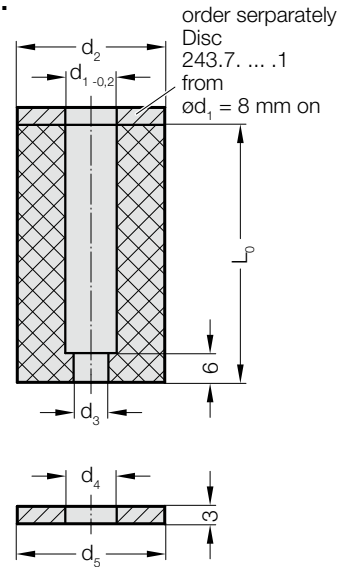

Description:

Repairs, sharpening and modifications on dies equipped with elastomer strippers do not necessitate the dismantling of a stripper plate, thus becoming very expedient. Any marring of delicate part surfaces is precluded. This makes elastomer strippers ideal for all painted, anodized, plastic-coated and polished parts. FIBROFLEX® Elastomer Strippers are resistant against oils and greases.

Material:

FIBROFLEX®
Hardness: 95 Shore A

Execution:

Stock lengths: 39, 47, 56 mm.
Other lengths on request (max. 56 mm)!

Application:

Especially in large dies, where the use of elastomer strippers does away with the need of huge stripper plates.

Mounting:

Push stripper over punch, where it will stay put on account of its elasticity. No other form of retention will be required. A single press stroke will then pierce a hole through the bottom portion of the stripper that matches the punch shape exactly.

243.7. Elastomer Stripper

d ₁	d ₂	d ₃	L ₀	39	47	56
4	17	1.6		●	●	●
5	17	1.6		●	●	●
6	19	1.6		●	●	●
6.3	19	1.6		●	●	●
8	21	3		●	●	●
10	23	3		●	●	●
12.5	26	3		●	●	●
13	26	3		●	●	●
16	30	3		●	●	●
20	38	3		●	●	●
25	50	3		●	●	●
32	55	3		●	●	●
38	60	3		●	●	●
40	63	3		●	●	●

Ordering Code (example):

Elastomer Stripper	=	243.7.
Inner diameter d ₁	13 mm =	130.
Length L ₀	39 mm =	039
Order No	=	243.7. 130.039

WASHER

243.7. .1

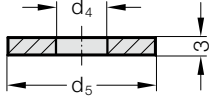

Material:

Steel

243.7. .1 Washer

Order No	d_4	d_5
243.7.085.1	8.5	21
243.7.105.1	10.5	23
243.7.130.1	13	26
243.7.135.1	13.5	26
243.7.165.1	16.5	30
243.7.205.1	20.5	38
243.7.255.1	25.5	50
243.7.325.1	32.5	55
243.7.385.1	38.5	60
243.7.405.1	40.5	63

POLY STRIP STRIPPER UNIT - ORDER EXAMPLES

Note: See table for standard dimensions
Special dimensions to order

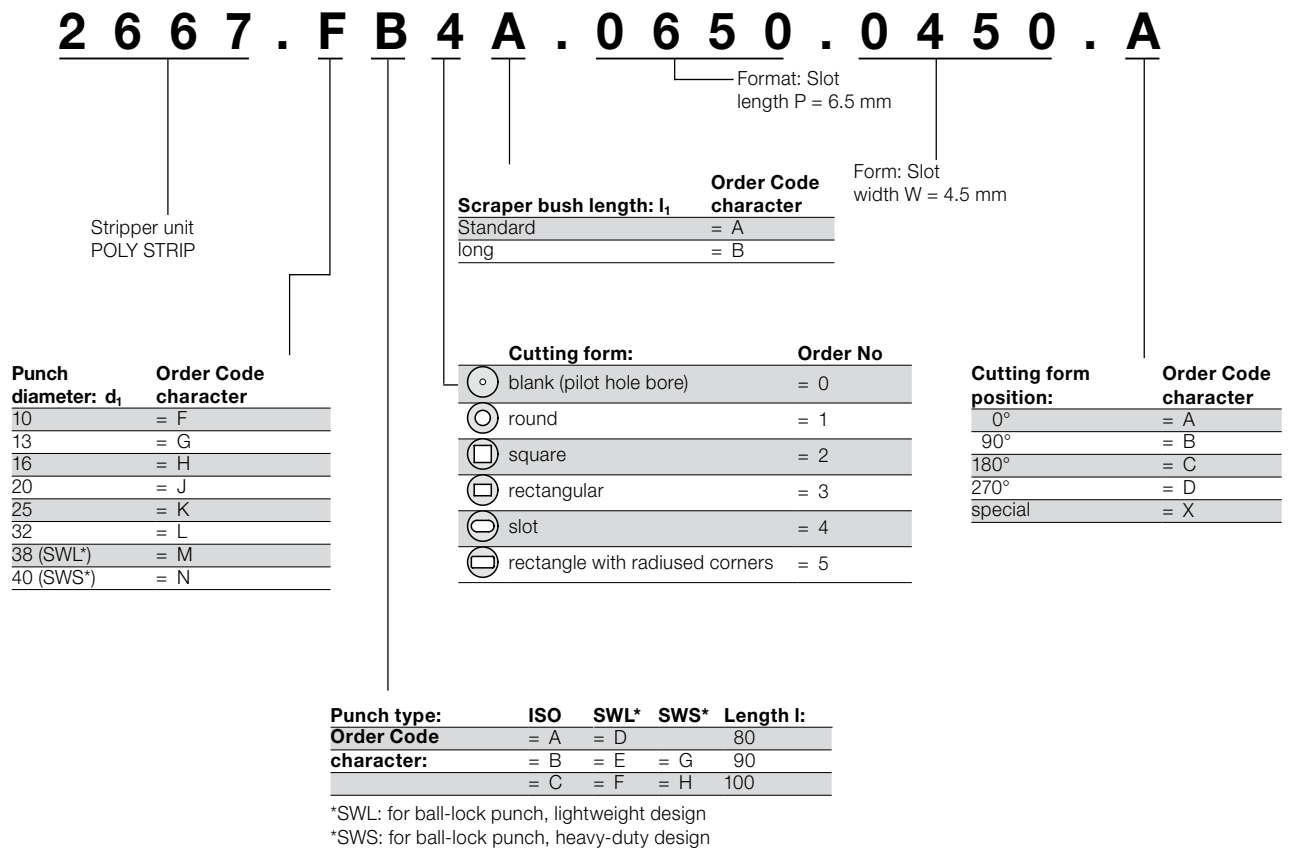

Ordering Code (example):

2 6 6 7 . F B 4 A . 0 6 5 0 . 0 4 5 0 . A

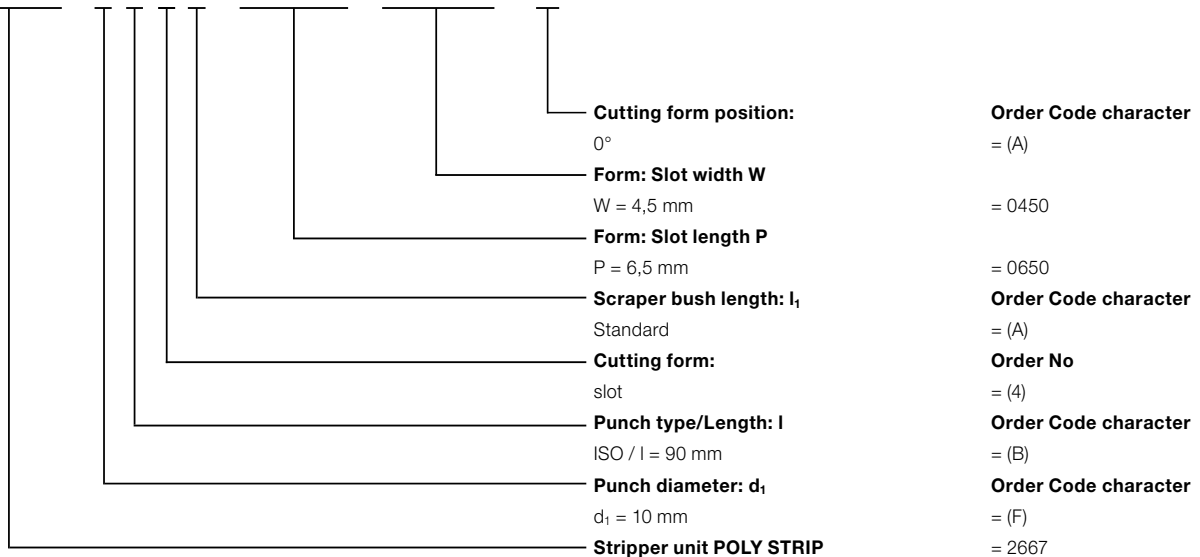

POLY STRIP STRIPPER UNIT, WITH START BOREHOLE, FOR ISO 8020 PUNCH

2667.□□0□.

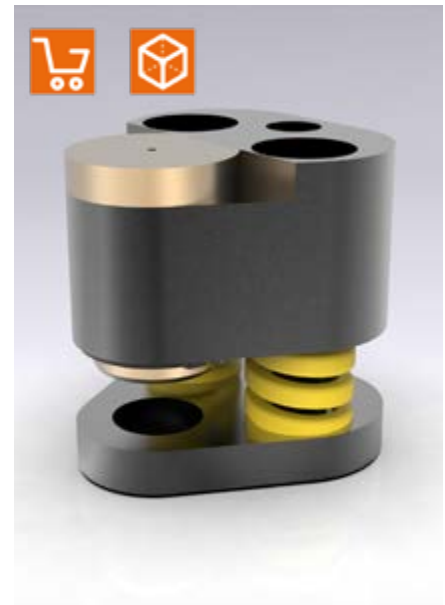
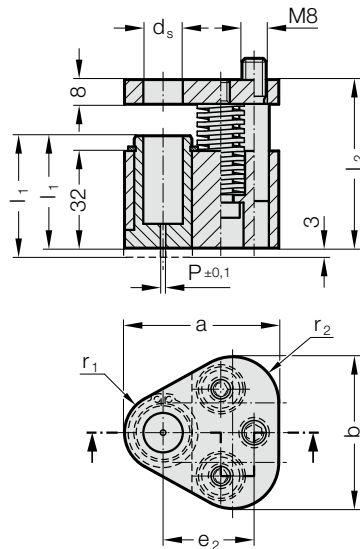

2667.xx0x. POLY STRIP stripper unit, with start borehole, for ISO 8020 punch

d _s / (Order Code character)	P	a	b	e ₂	r ₁	r ₂	l ₂ / (Order Code character)	80 (A)	90 (B)	100 (C)	l ₁ / (Order Code character)	37 (A)	40 (B)
								55.5	65.5	75.5	S _(max)		
10 / (F)	1.5	44.5	43.7	26.925	9.5	12		●	●	●		●	●
13 / (G)	1.5	50.8	50	29.97	12.7	15.2		●	●	●		●	●
16 / (H)	1.5	54	53.2	31.75	14.3	16.8		●	●	●		●	●
20 / (J)	1.5	60.3	59.5	33.53	17.5	20		●	●	●		●	●
25 / (K)	1.5	69.9	69.1	40.64	22.2	24.7		●	●	●		●	●
32 / (L)	1.5	69.9	69.1	40.64	22.2	24.7		●	●	●		●	●

d _s / (Order Code character)	Punch length l	80	80	90	90	100	100
	Scraper bush l ₁	37	40	37	40	37	40
	Stripping force max.[N]	1022	884	1280	810	786	1098
10 / (F)		1022	884	1280	810	786	1098
13 / (G)		1022	884	1280	810	786	1098
16 / (H)		2856	1668	3128	1282	1920	2688
20 / (J)		5049	2714	5124	2180	3120	4368
25 / (K)		5049	2714	5124	2180	3120	4368
32 / (L)		5049	2714	5124	2180	3120	4368

Ordering Code (example):

2667.FC0A.A

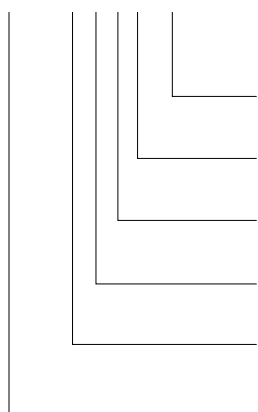

Cutting form position:

0°

Scraper bush length: l₁

Standard

Cutting form:

Start borehole

Punch type/length: l

ISO / l = 100 mm

Punch diameter: d_i

d_i = 10 mm

Stripper unit
POLY STRIP

Order Code character

= (A)

Order Code character

= (A)

Order No

= (0)

Order Code character

= (C)

Order Code character

= (F)

= 2667

Description:

The stripper unit is suitable for use with exterior skin panels.

Use with triangular mounting plate, for punch ISO 8020 2664.02./2664.04.

Material:

Scraper bush: CuZn25Al5 (no. 2.0598)

Scraper plate: 40CrMnMoS8-6 (no. 1.2312)

Pressure plate: 40CrMnMoS8-6 (no. 1.2312)

Note:

The stripper unit is available in 2 variants: Standard (A) and Long (B).

Long variant of the stripper unit with 3 mm projecting edge suitable for retrofitting a contour.

POLY STRIP STRIPPER UNIT, ROUND, FOR ISO 8020 PUNCH

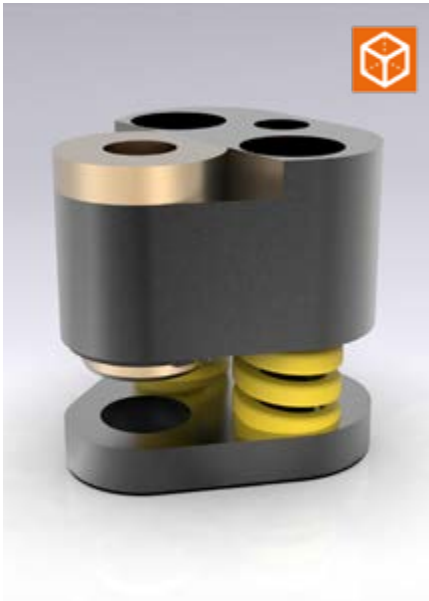

2667.□□1□.

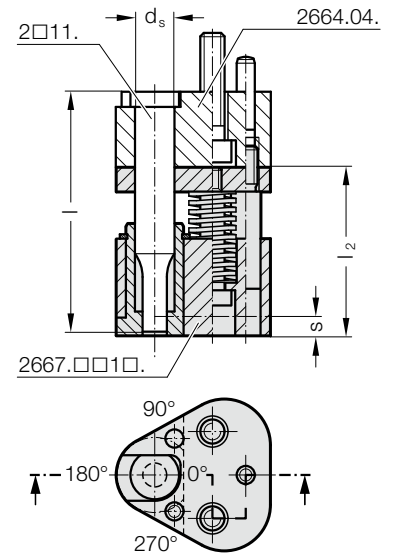
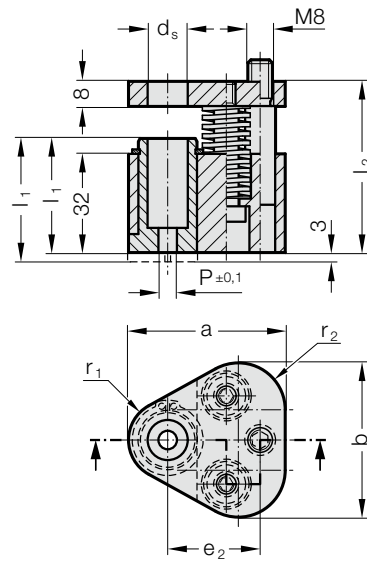

2667.xx1x. POLY STRIP stripper unit, round, for ISO 8020 punch

d _s / (Order Code character)	P	a	b	e ₂	r ₁	r ₂	l ₂ / (Order Code character)	80 (A)	90 (B)	100 (C)	l ₁ / (Order Code character)	37 (A)	40 (B)
											s _(max)	6.5	9.5
10 / (F)	4 - 9,9	44.5	43.7	26.925	9.5	12		●	●	●		●	●
13 / (G)	5 - 12,9	50.8	50	29.97	12.7	15.2		●	●	●		●	●
16 / (H)	8 - 15,9	54	53.2	31.75	14.3	16.8		●	●	●		●	●
20 / (J)	12 - 19,9	60.3	59.5	33.53	17.5	20		●	●	●		●	●
25 / (K)	16,5 - 24,9	69.9	69.1	40.64	22.2	24.7		●	●	●		●	●
32 / (L)	20 - 31,9	69.9	69.1	40.64	22.2	24.7		●	●	●		●	●

d _s / (Order Code character)	Punch length l	80	80	90	90	100	100
	Scraper bush l ₁	37	40	37	40	37	40
	Stripping force max. [N]	1022	884	1280	810	786	1098
10 / (F)		1022	884	1280	810	786	1098
13 / (G)		1022	884	1280	810	786	1098
16 / (H)		2856	1668	3128	1282	1920	2688
20 / (J)		5049	2714	5124	2180	3120	4368
25 / (K)		5049	2714	5124	2180	3120	4368
32 / (L)		5049	2714	5124	2180	3120	4368

Description:

The stripper unit is suitable for use with exterior skin panels.

Use with triangular mounting plate, for punch ISO 8020 2664.02./2664.04.

Material:

Scraper bush: CuZn25Al5 (no. 2.0598)

Scraper plate: 40CrMnMoS8-6 (no. 1.2312)

Pressure plate: 40CrMnMoS8-6 (no. 1.2312)

Note:

The stripper unit is available in 2 variants: Standard (A) and Long (B).

Long variant of the stripper unit with 3 mm projecting edge suitable for retrofitting a contour.

Choose the position of the cutting form in the scraper bush in accordance with the position of the installed punch in the mounting plate.

Ordering Code (example):

2667.FC1A.0400.A

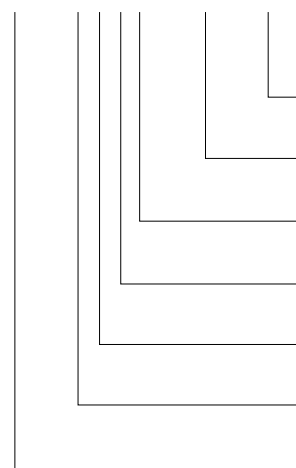

Cutting form position:

0°

Shape: round

P = ø4,0 mm

Scraper bush length: l₁

Standard

Cutting form:

round

Punch type/length: l

ISO / l = 100 mm

Punch diameter: d₁

d₁ = 10 mm

Stripper unit POLY STRIP

Order Code character

= (A)

= 0400

Order Code character

= (A)

Order No

= (1)

Order Code character

= (C)

Order Code character

= (F)

= 2667

POLY STRIP STRIPPER UNIT, SQUARE, FOR ISO 8020 PUNCH

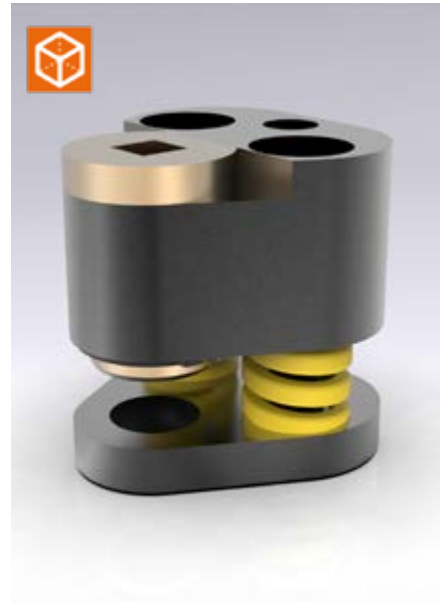
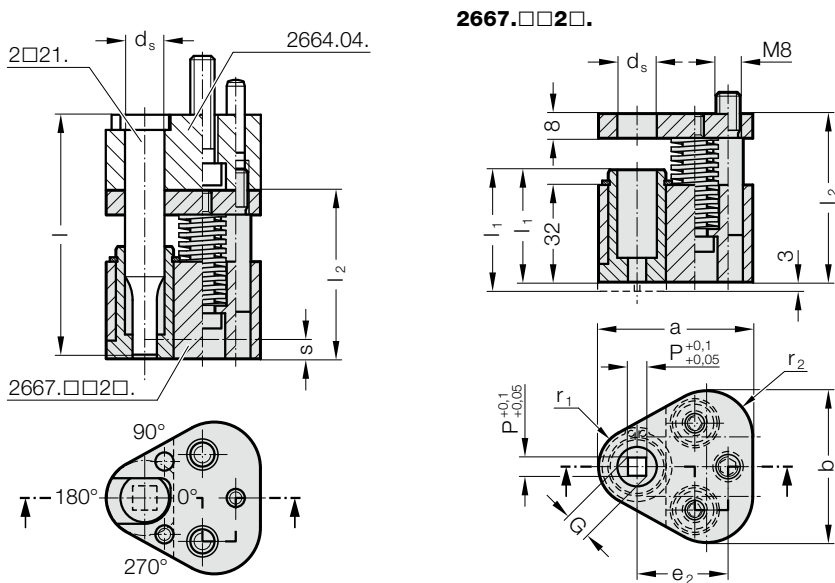

2667.xx2x. POLY STRIP stripper unit, square, for ISO 8020 punch

d _s / (Order Code character)	P _{min}	G _{max}	a	b	e ₂	r ₁	r ₂	l ₂	80 (A)	90 (B)	100 (C)	l ₁ S _(max)	37 (A)	40 (B)
10 / (F)	3.5	9.9	44.5	43.7	26.925	9.5	12		●	●	●		●	●
13 / (G)	4.5	12.9	50.8	50	29.97	12.7	15.2		●	●	●		●	●
16 / (H)	6	15.9	54	53.2	31.75	14.3	16.8		●	●	●		●	●
20 / (J)	8	19.9	60.3	59.5	33.53	17.5	20		●	●	●		●	●
25 / (K)	10	24.9	69.9	69.1	40.64	22.2	24.7		●	●	●		●	●
32 / (L)	10	31.9	69.9	69.1	40.64	22.2	24.7		●	●	●		●	●

d _s / (Order Code character)	Punch length l	80	80	90	90	100	100
10 / (F)	Scraper bush l ₁	37	40	37	40	37	40
	Stripping force max.[N]	1022	884	1280	810	786	1098
13 / (G)		1022	884	1280	810	786	1098
16 / (H)		2856	1668	3128	1282	1920	2688
20 / (J)		5049	2714	5124	2180	3120	4368
25 / (K)		5049	2714	5124	2180	3120	4368
32 / (L)		5049	2714	5124	2180	3120	4368

Ordering Code (example):

2667.FB2A.0400.A

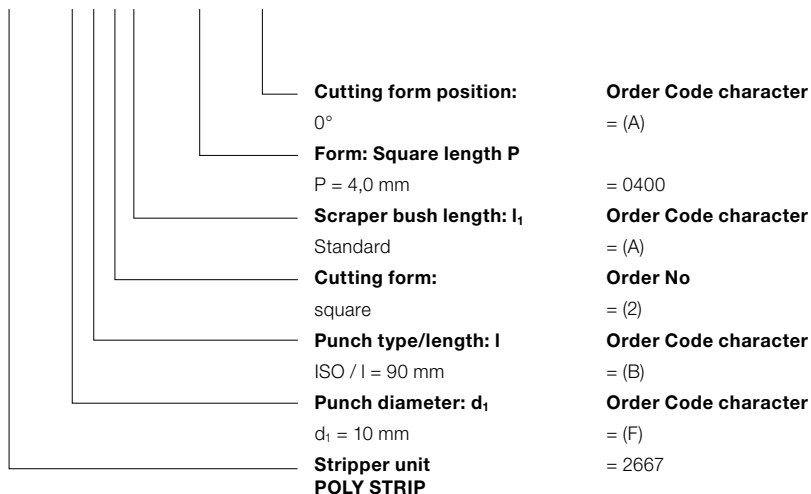

Description:

The stripper unit is suitable for use with exterior skin panels.
Use with triangular mounting plate, for punch ISO 8020 2664.04.

Material:

Scraper bush: CuZn25Al5 (no. 2.0598)
Scraper plate: 40CrMnMoS8-6 (no. 1.2312)
Pressure plate: 40CrMnMoS8-6 (no. 1.2312)

Note:

The stripper unit is available in 2 variants: Standard (A) and Long (B).
Long variant of the stripper unit with 3 mm projecting edge suitable for retrofitting a contour.
Choose the position of the cutting form in the scraper bush in accordance with the position of the installed punch in the mounting plate.

POLY STRIP STRIPPER UNIT, RECTANGLE, FOR ISO 8020 PUNCH

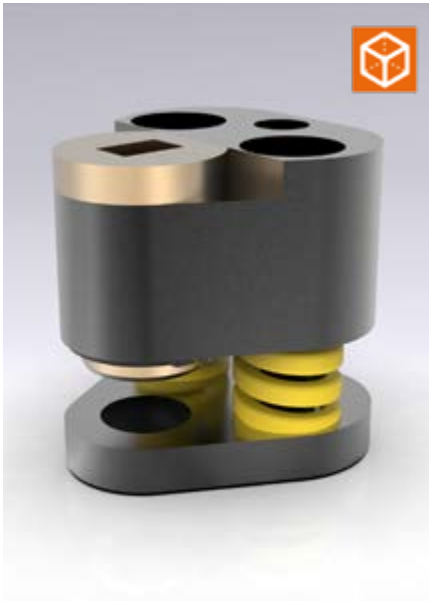

2667.□□3□.

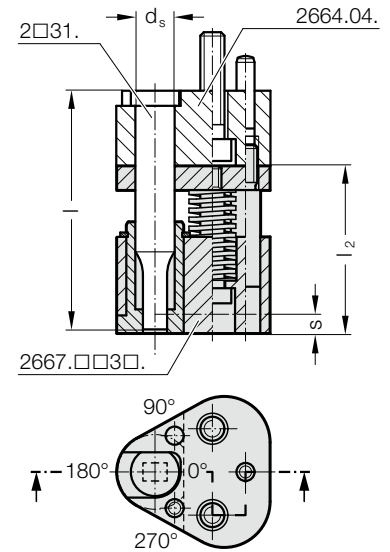
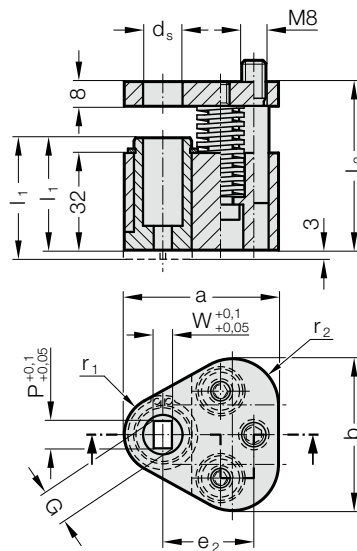

2667.xx3x. POLY STRIP stripper unit, rectangle, for ISO 8020 punch

d_s / (Order Code character)	W_{min}	G_{max}	a	b	e_2	r_1	r_2	l / (Order Code character)	80 (A)	90 (B)	100 (C)	l_1 / (Order Code character)	37 (A)	40 (B)
								l_2	55.5	65.5	75.5	$s_{(max)}$	6.5	9.5
10 / (F)	3.5	9.9	44.5	43.7	26.925	9.5	12		●	●	●		●	●
13 / (G)	4.5	12.9	50.8	50	29.97	12.7	15.2		●	●	●		●	●
16 / (H)	6	15.9	54	53.2	31.75	14.3	16.8		●	●	●		●	●
20 / (J)	8	19.9	60.3	59.5	33.53	17.5	20		●	●	●		●	●
25 / (K)	10	24.9	69.9	69.1	40.64	22.2	24.7		●	●	●		●	●
32 / (L)	10	31.9	69.9	69.1	40.64	22.2	24.7		●	●	●		●	●

d_s / (Order Code character)	Punch length l	80	80	90	90	100	100
	Scraper bush l_1	37	40	37	40	37	40
	Stripping force max. [N]	1022	884	1280	810	786	1098
10 / (F)		1022	884	1280	810	786	1098
13 / (G)		1022	884	1280	810	786	1098
16 / (H)		2856	1668	3128	1282	1920	2688
20 / (J)		5049	2714	5124	2180	3120	4368
25 / (K)		5049	2714	5124	2180	3120	4368
32 / (L)		5049	2714	5124	2180	3120	4368

Description:

The stripper unit is suitable for use with exterior skin panels.

Use with triangular mounting plate, for punch ISO 8020 2664.04.

Material:

Scraper bush: CuZn25Al5 (no. 2.0598)

Scraper plate: 40CrMnMoS8-6 (no. 1.2312)

Pressure plate: 40CrMnMoS8-6 (no. 1.2312)

Note:

The stripper unit is available in 2 variants: Standard (A) and Long (B).

Long variant of the stripper unit with 3 mm projecting edge suitable for retrofitting a contour.

Choose the position of the cutting form in the scraper bush in accordance with the position of the installed punch in the mounting plate.

Ordering Code (example):

2667.FB3A.0800.0500.A

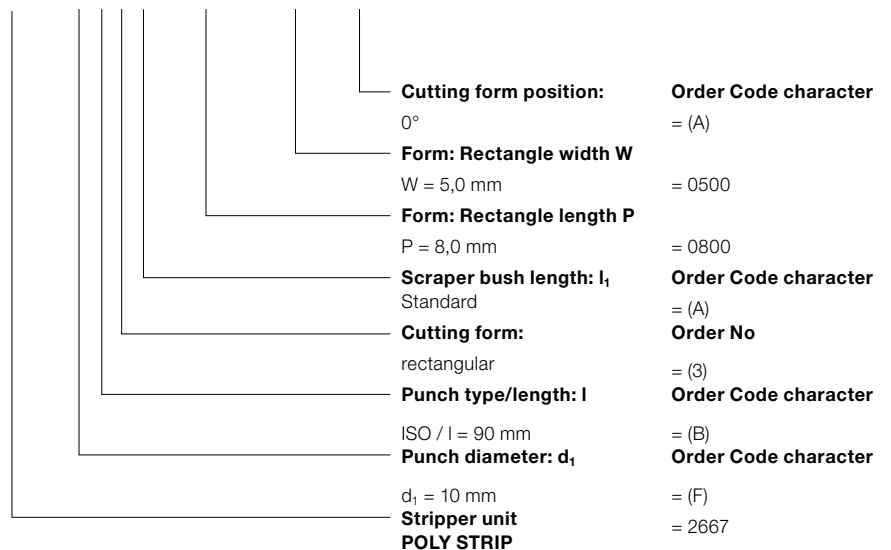

POLY STRIP STRIPPER UNIT, SLOT, FOR ISO 8020 PUNCH

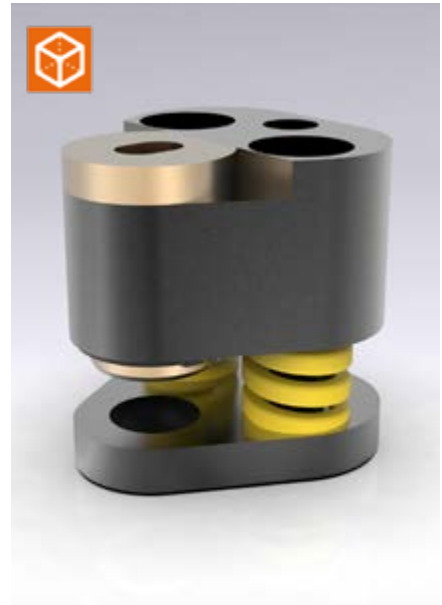
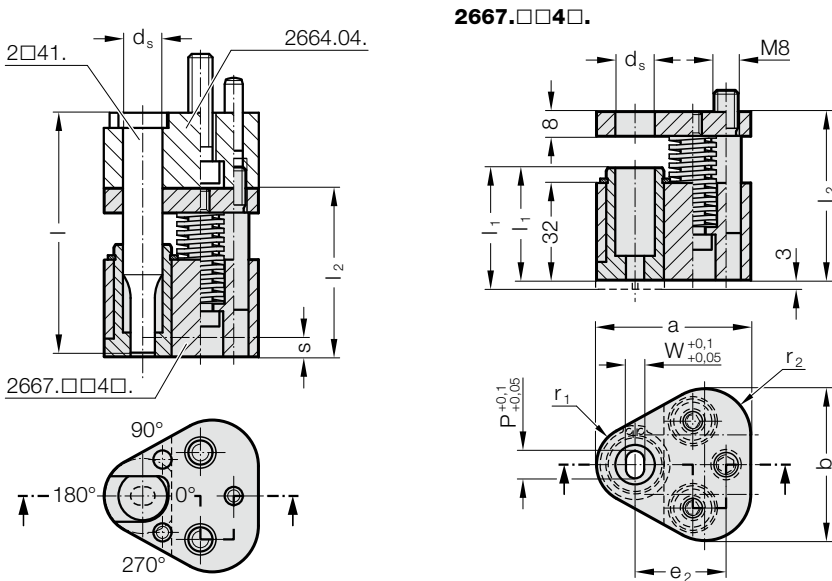

2667.xx4x. POLY STRIP stripper unit, slot, for ISO 8020 punch

d _s / (Order Code character)	W _{min}	G _{max}	a	b	e ₂	r ₁	r ₂	l ₁ (Order Code character)	80 (A)	90 (B)	100 (C)	l ₂ (Order Code character)	37 (A)	40 (B)
10 / (F)	3.5	9.9	44.5	43.7	26.925	9.5	12	l _{2(max)}	55.5	65.5	75.5		6.5	9.5
13 / (G)	4.5	12.9	50.8	50	29.97	12.7	15.2		●	●	●		●	●
16 / (H)	6	15.9	54	53.2	31.75	14.3	16.8		●	●	●		●	●
20 / (J)	8	19.9	60.3	59.5	33.53	17.5	20		●	●	●		●	●
25 / (K)	10	24.9	69.9	69.1	40.64	22.2	24.7		●	●	●		●	●
32 / (L)	10	31.9	69.9	69.1	40.64	22.2	24.7		●	●	●		●	●

d _s / (Order Code character)	Punch length l	80	80	90	90	100	100
10 / (F)	Scraper bush l ₁	37	40	37	40	37	40
	Stripping force max. [N]	1022	884	1280	810	786	1098
13 / (G)		1022	884	1280	810	786	1098
16 / (H)		2856	1668	3128	1282	1920	2688
20 / (J)		5049	2714	5124	2180	3120	4368
25 / (K)		5049	2714	5124	2180	3120	4368
32 / (L)		5049	2714	5124	2180	3120	4368

Ordering Code (example):

2667.FB4A.0800.0500.A

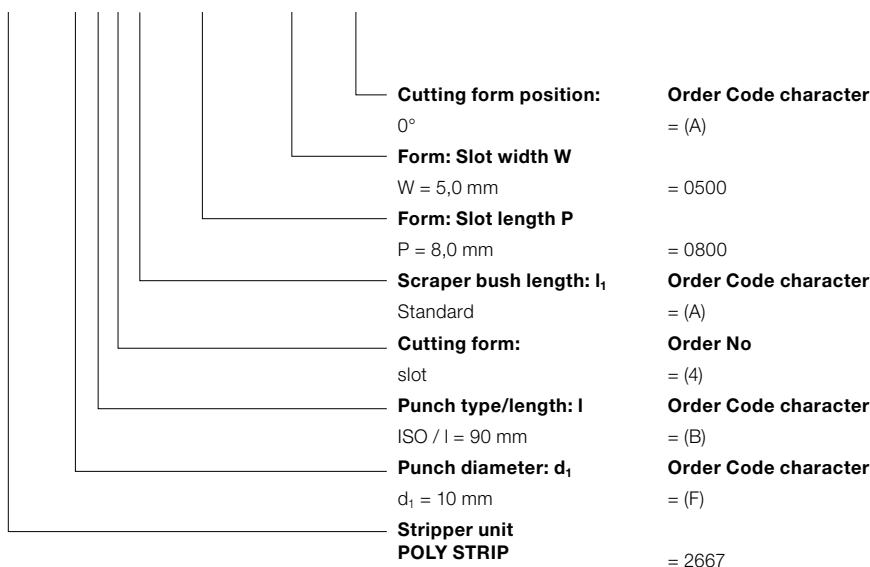

Description:

The stripper unit is suitable for use with exterior skin panels. Use with triangular mounting plate, for punch ISO 8020 2664.04.

Material:

Scraper bush: CuZn25Al5 (no. 2.0598)
Scraper plate: 40CrMnMoS8-6 (no. 1.2312)
Pressure plate: 40CrMnMoS8-6 (no. 1.2312)

Note:

The stripper unit is available in 2 variants: Standard (A) and Long (B). Long variant of the stripper unit with 3 mm projecting edge suitable for retrofitting a contour. Choose the position of the cutting form in the scraper bush in accordance with the position of the installed punch in the mounting plate.

POLY STRIP STRIPPER UNIT, RECTANGLE WITH RADIUS, FOR ISO 8020 PUNCH

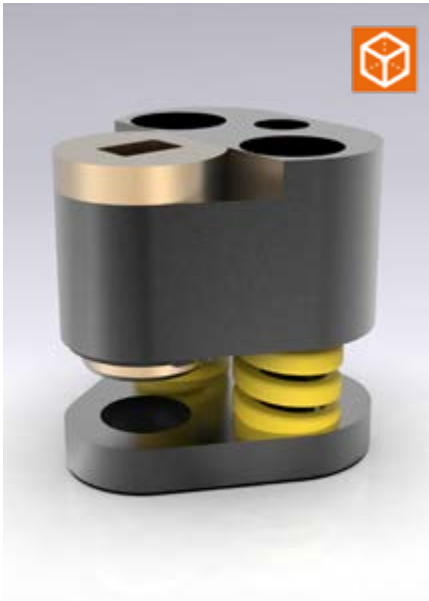

2667.□□5□.

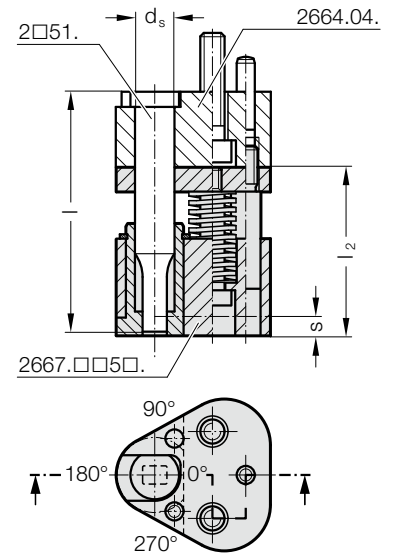
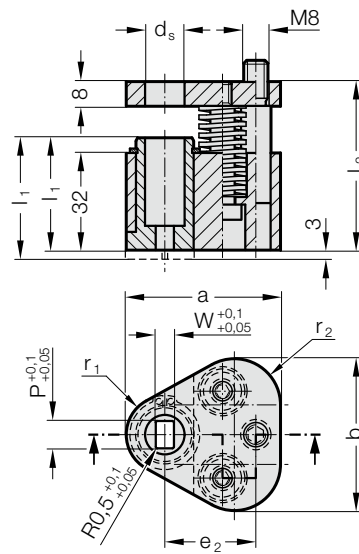

2667.xx5x. POLY STRIP stripper unit, rectangle with radius, for ISO 8020 punch

d_s / (Order Code character)	W_{min}	G_{max}	a	b	e_2	r_1	r_2	l (Order Code character)	80 (A)	90 (B)	100 (C)	l_1 (Order Code character)	37 (A)	40 (B)
								l_2	55.5	65.5	75.5	$s_{(max)}$	6.5	9.5
10 / (F)	3.5	9.9	44.5	43.7	26.925	9.5	12		●	●	●		●	●
13 / (G)	4.5	12.9	50.8	50	29.97	12.7	15.2		●	●	●		●	●
16 / (H)	6	15.9	54	53.2	31.75	14.3	16.8		●	●	●		●	●
20 / (J)	8	19.9	60.3	59.5	33.53	17.5	20		●	●	●		●	●
25 / (K)	10	24.9	69.9	69.1	40.64	22.2	24.7		●	●	●		●	●
32 / (L)	10	31.9	69.9	69.1	40.64	22.2	24.7		●	●	●		●	●

d_s / (Order Code character)	Punch length l	80	80	90	90	100	100
	Scraper bush l_1	37	40	37	40	37	40
	Stripping force max. [N]	1022	884	1280	810	786	1098
10 / (F)		1022	884	1280	810	786	1098
13 / (G)		1022	884	1280	810	786	1098
16 / (H)		2856	1668	3128	1282	1920	2688
20 / (J)		5049	2714	5124	2180	3120	4368
25 / (K)		5049	2714	5124	2180	3120	4368
32 / (L)		5049	2714	5124	2180	3120	4368

Description:

The stripper unit is suitable for use with exterior skin panels.

Use with triangular mounting plate, for punch ISO 8020 2664.04.

Material:

Scraper bush: CuZn25Al5 (no. 2.0598)

Scraper plate: 40CrMnMoS8-6 (no. 1.2312)

Pressure plate: 40CrMnMoS8-6 (no. 1.2312)

Note:

The stripper unit is available in 2 variants: Standard (A) and Long (B).

Long variant of the stripper unit with 3 mm projecting edge suitable for retrofitting a contour.

Choose the position of the cutting form in the scraper bush in accordance with the position of the installed punch in the mounting plate.

Ordering Code (example):

2667.FB5A.0800.0500.A

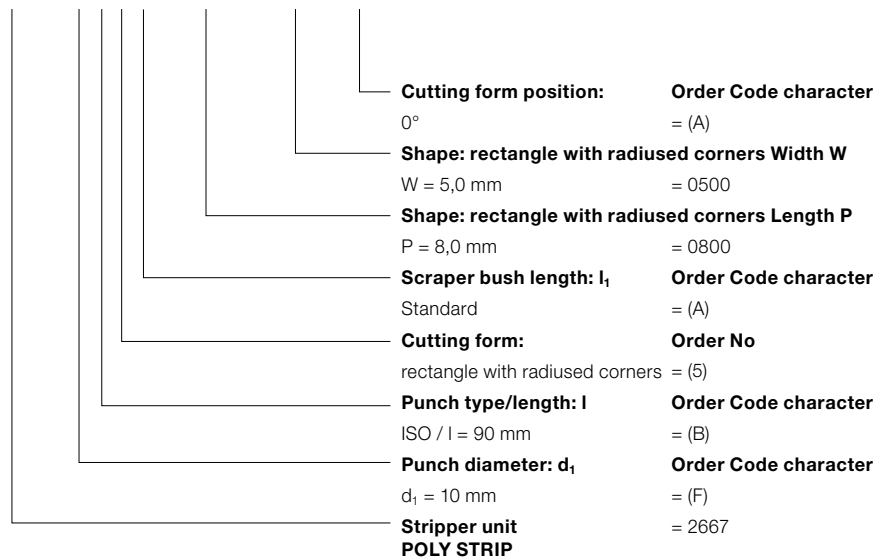

POLY STRIP STRIPPER UNIT, WITH START BOREHOLE, FOR BALL-LOCK PUNCH

2667.□□0□.

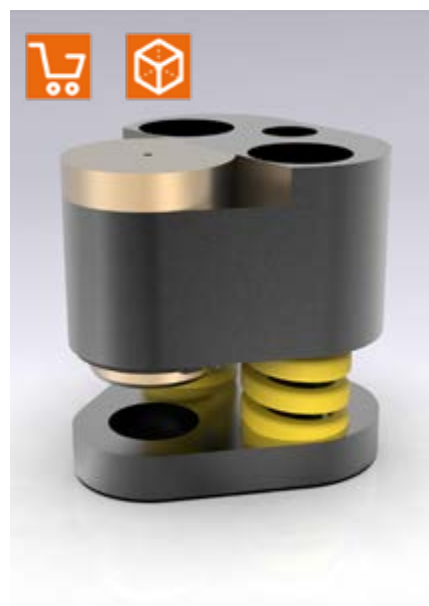
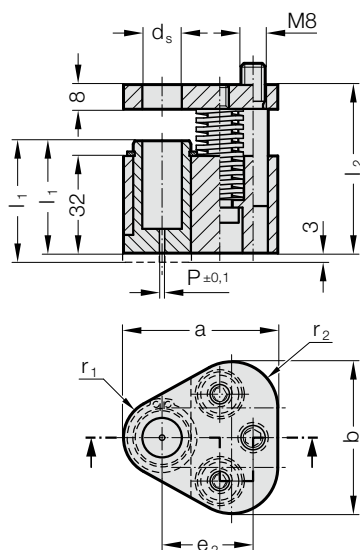

2667.xx0x. POLY STRIP stripper unit, with start borehole, for ball-lock punch

d _s / (Order Code character)	P	a	b	e ₂	r ₁	r ₂	Punch type					l ₁	37	40	
							l	SWL	SWL	SWS	SWL				SWS
							(Order Code character)	(D)	(E)	(G)	(F)	(H)			
10 / (F)	1.5	44.5	43.7	26.925	9.5	12	l ₂	55.5	65.5	55.5	75.5	65.5			
13 / (G)	1.5	50.8	50	29.97	12.7	15.2		●	●	●	●	●			
16 / (H)	1.5	54	53.2	31.75	14.3	16.8		●	●	●	●	●			
20 / (J)	1.5	60.3	59.5	33.53	17.5	20		●	●	●	●	●			
25 / (K)	1.5	69.9	69.1	40.64	22.2	24.7		●	●	●	●	●			
32 / (L)	1.5	69.9	69.1	40.64	22.2	24.7		●	●	●	●	●			
38 / (M)	1.5	77.4	76.6	43.99	26	28.5		●	●	●	●	●			
40 / (N)	1.5	77.4	76.6	43.99	26	28.5				●	●				

d _s / (Order Code character)	Punch type	Punch length l	Scraper bush l ₁	Stripping force max.[N]	SWL				SWS				
					080	080	090	090	100	100	090	090	100
10 / (F)				1022	884	1280	810	786	1098	1022	884	1280	810
13 / (G)				1022	884	1280	810	786	1098	1022	884	1280	810
16 / (H)				2856	1668	3128	1282	1920	2688	2856	1668	3128	1282
20 / (J)				5049	2714	5124	2180	3120	4368	5049	2714	5124	2180
25 / (K)				5049	2714	5124	2180	3120	4368	5049	2714	5124	2180
32 / (L)				5049	2714	5124	2180	3120	4368	5049	2714	5124	2180
38 / (M)				5049	2714	5124	2180	3120	4368				
40 / (N)										5049	2714	5124	2180

Ordering Code (example):

2667.FE0A.A

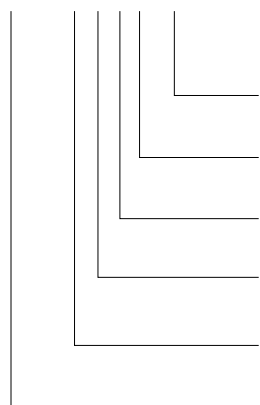

Cutting form position:

0°

Scraper bush length: l₁

Standard

Cutting form:

Start borehole

Punch type/length: l

SWL / l = 90 mm

Punch diameter: d₁

d₁ = 10 mm

Stripper unit
POLY STRIP

Order Code character

= (A)

Order Code character

= (A)

Order No

= (0)

Order Code character

= (E)

Order Code character

= (F)

= 2667

Description:

The brush cleaner unit is suitable for use with exterior skin panels.

Use with triangular mounting plate, for ball-lock punch 2664.05./06./10.

Material:

Scraper bush: CuZn25Al5 (no. 2.0598)

Scraper plate: 40CrMnMoS8-6 (no. 1.2312)

Pressure plate: 40CrMnMoS8-6 (no. 1.2312)

Note:

The stripper unit is available in 2 variants: Standard (A) and Long (B).

Long variant of the stripper unit with 3 mm projecting edge suitable for retrofitting a contour.

POLY STRIP STRIPPER UNIT, ROUND, FOR BALL-LOCK PUNCH

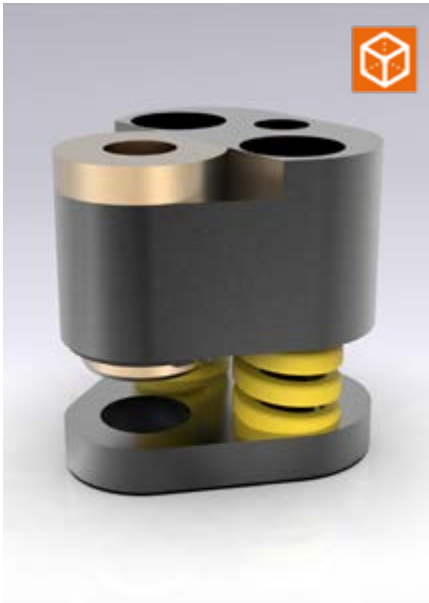

2667.□□1□.

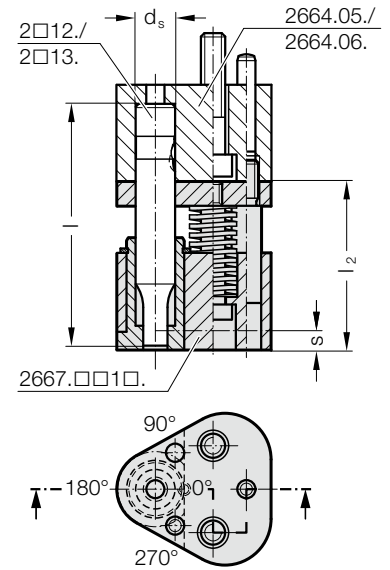
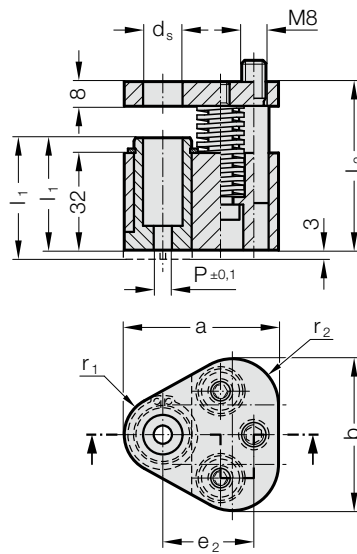

2667.xx1x. POLY STRIP stripper unit, round, for ball-lock punch

d _s / (Order Code character)	P	a	b	e ₂	r ₁	r ₂	Punch type					l ₁ (Order Code character)	37 (A)	40 (B)
							l	SWL	SWS	SWL	SWS			
10 / (F)	1,6 - 9,9	44.5	43.7	26.925	9.5	12	80	90	90	100	100	(Order Code character)	6.5	9.5
13 / (G)	5 - 12,9	50.8	50	29.97	12.7	15.2	●	●	●	●	●		●	●
16 / (H)	8 - 15,9	54	53.2	31.75	14.3	16.8	●	●	●	●	●		●	●
20 / (J)	12 - 19,9	60.3	59.5	33.53	17.5	20	●	●	●	●	●		●	●
25 / (K)	16 - 24,9	69.9	69.1	40.64	22.2	24.7	●	●	●	●	●		●	●
32 / (L)	24 - 31,9	69.9	69.1	40.64	22.2	24.7	●	●	●	●	●		●	●
38 / (M)	30 - 37,9	77.4	76	43.9	26	28.5	●	●	●	●	●		●	●
40 / (N)	30 - 39,9	77.4	76	43.9	26	28.5		●		●			●	●

d _s / (Order Code character)	Punch type	Punch length l	Scraper bush l ₁	Stripping force max.[N]	SWL	SWL	SWL	SWL	SWL	SWL	SWS	SWS	SWS	SWS
					080	080	090	090	100	100	090	090	100	100
10 / (F)	37	40	37	1022	884	1280	810	786	1098	1022	884	1280	810	
13 / (G)				1022	884	1280	810	786	1098	1022	884	1280	810	
16 / (H)				2856	1668	3128	1282	1920	2688	2856	1668	3128	1282	
20 / (J)				5049	2714	5124	2180	3120	4368	5049	2714	5124	2180	
25 / (K)				5049	2714	5124	2180	3120	4368	5049	2714	5124	2180	
32 / (L)				5049	2714	5124	2180	3120	4368	5049	2714	5124	2180	
38 / (M)				5049	2714	5124	2180	3120	4368					
40 / (N)										5049	2714	5124	2180	

Description:

The brush cleaner unit is suitable for use with exterior skin panels.
Use with triangular mounting plate, for ball-lock punch 2664.05./06./10.

Material:

Scraper bush: CuZn25Al5 (no. 2.0598)
Scraper plate: 40CrMnMoS8-6 (no. 1.2312)
Pressure plate: 40CrMnMoS8-6 (no. 1.2312)

Note:

The stripper unit is available in 2 variants: Standard (A) and Long (B).
Long variant of the stripper unit with 3 mm projecting edge suitable for retrofitting a contour.
Choose the position of the cutting form in the scraper bush in accordance with the position of the installed punch in the mounting plate.

Ordering Code (example):

2667.FE1A.0400.A

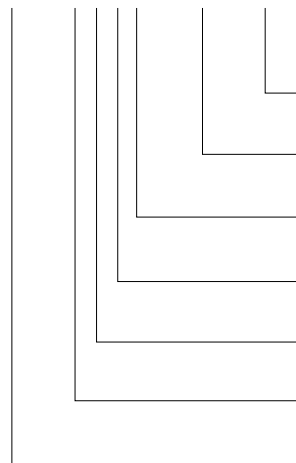

- Cutting form position:** 0° = (A)
- Shape: round P** P = ø4,0 mm = 0400
- Scraper bush length: l₁** Standard = (A)
- Cutting form:** round = (1)
- Punch type/length: l** SWL / l = 90 mm = (E)
- Punch diameter: d₁** d₁ = 10 mm = (F)
- Stripper unit** POLY STRIP = 2667

POLY STRIP STRIPPER UNIT, SQUARE, FOR BALL-LOCK PUNCH

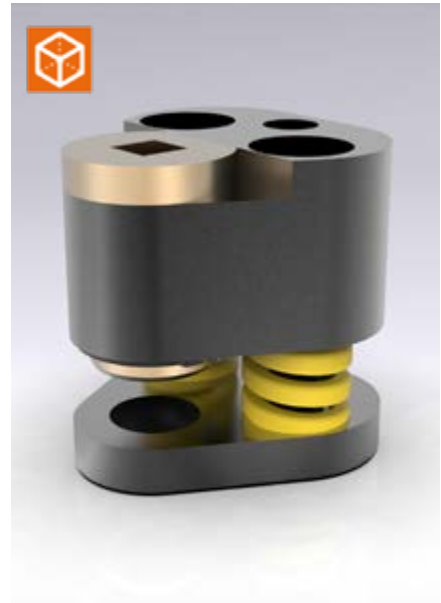
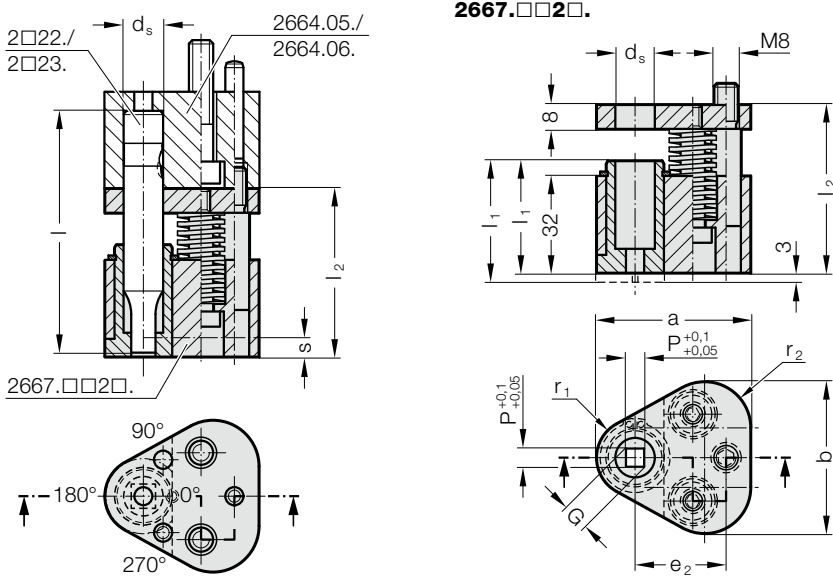

2667.xx2x. POLY STRIP stripper unit, square, for ball-lock punch

d _s / (Order Code character)	P _{min}	G _{max}	a	b	e ₂	r ₁	r ₂	Punch type l ₂ (Order Code character)	SWL	SWS	SWL	SWS	SWL	l ₁ s _(max)	37	40
									(D)	(G)	(E)	(H)	(F)		(A)	(B)
10 / (F)	1.6	9.9	44.5	43.7	26.925	9.5	12	l	80	90	90	100	100			
13 / (G)	4.5	12.9	50.8	50	29.97	12.7	15.2									
16 / (H)	6	15.9	54	53.2	31.75	14.3	16.8									
20 / (J)	8	19.9	60.3	59.5	33.53	17.5	20									
25 / (K)	10	24.9	69.9	69.1	40.64	22.2	24.7									
32 / (L)	12.5	31.9	69.9	69.1	40.64	22.2	24.7									
38 / (M)	14	37.9	77.4	76	43.9	26	28.5									
40 / (N)	14	39.9	77.4	76	43.9	26	28.5									

d _s / (Order Code character)	Punch type Punch length l ₁ Scraper bush l ₁	Stripping force max. [N]	SWL	SWL	SWL	SWL	SWL	SWL	SWS	SWS	SWS	SWS
			080	080	090	090	100	100	090	090	100	100
10 / (F)	37	1022	884	1280	810	786	1098	1022	884	1280	810	
13 / (G)		1022	884	1280	810	786	1098	1022	884	1280	810	
16 / (H)		2856	1668	3128	1282	1920	2688	2856	1668	3128	1282	
20 / (J)		5049	2714	5124	2180	3120	4368	5049	2714	5124	2180	
25 / (K)		5049	2714	5124	2180	3120	4368	5049	2714	5124	2180	
32 / (L)		5049	2714	5124	2180	3120	4368	5049	2714	5124	2180	
38 / (M)		5049	2714	5124	2180	3120	4368					
40 / (N)								5049	2714	5124	2180	

Ordering Code (example):

2667.FE2A.0400.A

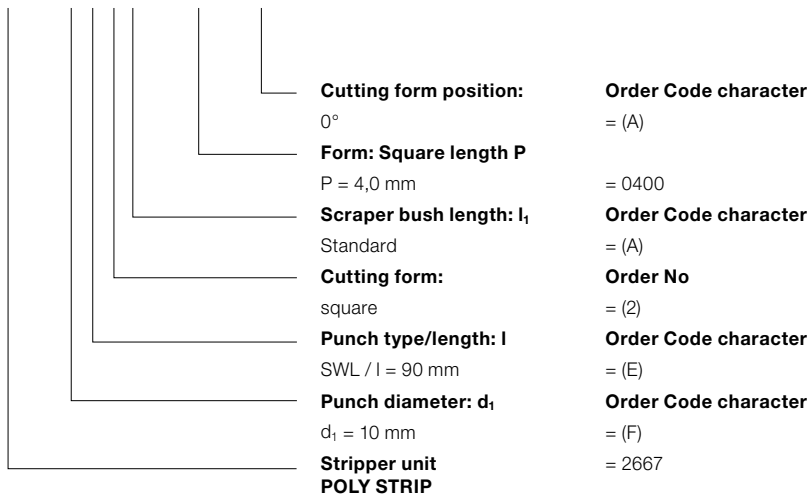

Description:

The brush cleaner unit is suitable for use with exterior skin panels. Use with triangular mounting plate, for ball-lock punch 2664.05./06./10.

Material:

Scraper bush: CuZn25Al5 (no. 2.0598)
Scraper plate: 40CrMnMoS8-6 (no. 1.2312)
Pressure plate: 40CrMnMoS8-6 (no. 1.2312)

Note:

The stripper unit is available in 2 variants: Standard (A) and Long (B). Long variant of the stripper unit with 3 mm projecting edge suitable for retrofitting a contour. Choose the position of the cutting form in the scraper bush in accordance with the position of the installed punch in the mounting plate.

POLY STRIP STRIPPER UNIT, RECTANGLE, FOR BALL-LOCK PUNCH

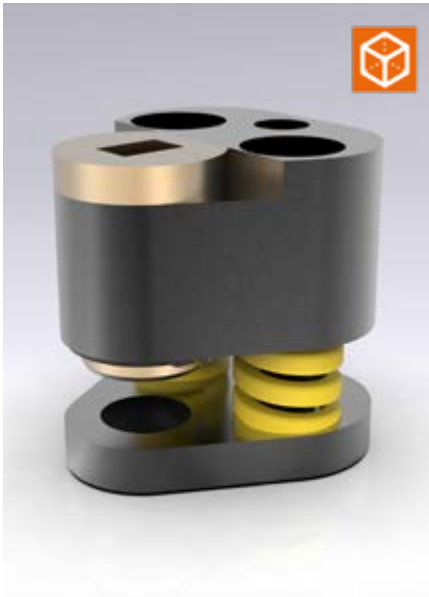

2667.□□3□.

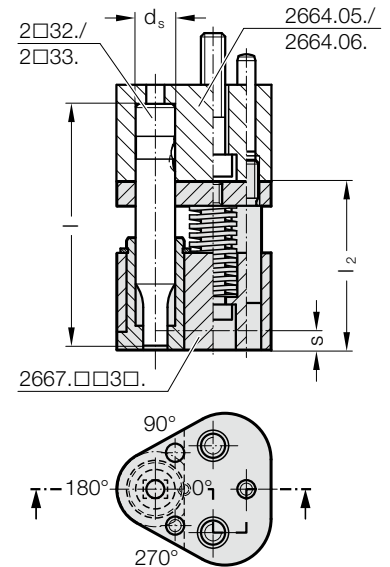
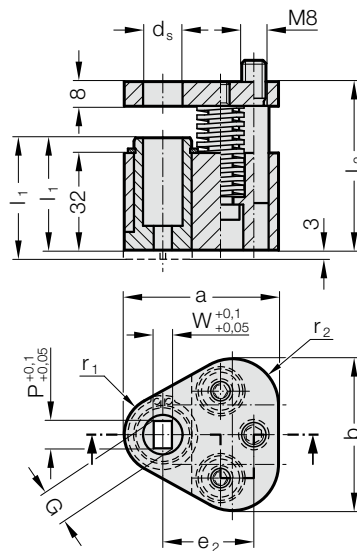

2667.xx3x. POLY STRIP stripper unit, rectangle, for ball-lock punch

d _s / (Order Code character)	W _{min}	G _{max}	a	b	e ₂	r ₁	r ₂	Punch type					l ₁ (Order Code character)	37 (A)	40 (B)
								l	SWL	SWS	SWL	SWS			
10 / (F)	1.6	9.9	44.5	43.7	26.925	9.5	12	80	90	90	100	100	(Order Code character)		
13 / (G)	4.5	12.9	50.8	50	29.97	12.7	15.2	80	90	90	100	100			
16 / (H)	6	15.9	54	53.2	31.75	14.3	16.8	80	90	90	100	100			
20 / (J)	8	19.9	60.3	59.5	33.53	17.5	20	80	90	90	100	100			
25 / (K)	10	24.9	69.9	69.1	40.64	22.2	24.7	80	90	90	100	100			
32 / (L)	12.5	31.9	69.9	69.1	40.64	22.2	24.7	80	90	90	100	100			
38 / (M)	14	37.9	77.4	76	43.9	26	28.5	80	90	90	100	100			
40 / (N)	14	39.9	77.4	76	43.9	26	28.5	80	90	90	100	100			

d _s / (Order Code character)	Punch type	Punch length l	Scraper bush l ₁	Stripping force max. [N]	SWL	SWL	SWL	SWL	SWL	SWL	SWS	SWS	SWS	SWS
					080	080	090	090	100	100	090	090	100	100
10 / (F)			37	1022	884	1280	810	786	1098	1022	884	1280	810	
13 / (G)			40	1022	884	1280	810	786	1098	1022	884	1280	810	
16 / (H)			37	2856	1668	3128	1282	1920	2688	2856	1668	3128	1282	
20 / (J)			40	5049	2714	5124	2180	3120	4368	5049	2714	5124	2180	
25 / (K)			37	5049	2714	5124	2180	3120	4368	5049	2714	5124	2180	
32 / (L)			40	5049	2714	5124	2180	3120	4368	5049	2714	5124	2180	
38 / (M)			37	5049	2714	5124	2180	3120	4368					
40 / (N)			40	5049	2714	5124	2180	3120	4368	5049	2714	5124	2180	

Description:

The brush cleaner unit is suitable for use with exterior skin panels.
Use with triangular mounting plate, for ball-lock punch 2664.05./06./10.

Material:

Scraper bush: CuZn25Al5 (no. 2.0598)
Scraper plate: 40CrMnMoS8-6 (no. 1.2312)
Pressure plate: 40CrMnMoS8-6 (no. 1.2312)

Note:

The stripper unit is available in 2 variants: Standard (A) and Long (B).
Long variant of the stripper unit with 3 mm projecting edge suitable for retrofitting a contour.
Choose the position of the cutting form in the scraper bush in accordance with the position of the installed punch in the mounting plate.

Ordering Code (example):

2667.FE3A.0800.0500.A

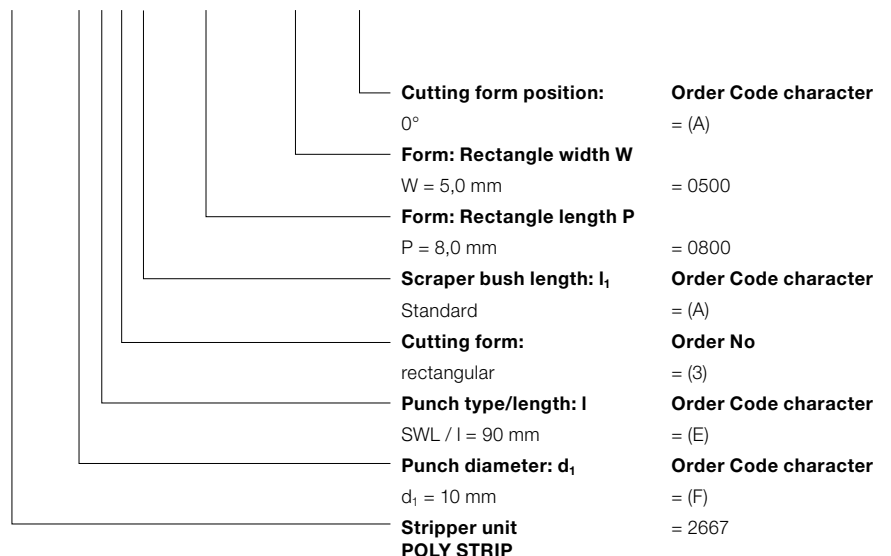

POLY STRIP STRIPPER UNIT, SLOT, FOR BALL-LOCK PUNCH

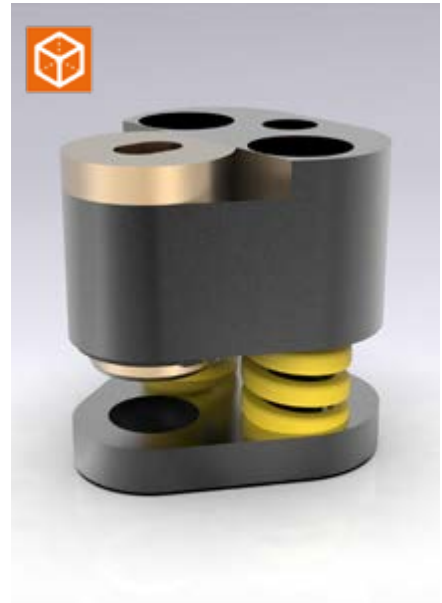
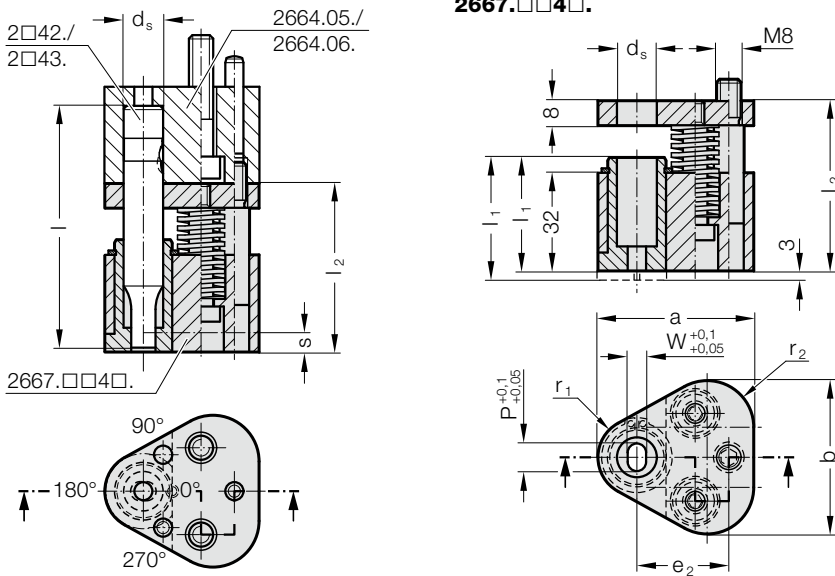

2667.xx4x. POLY STRIP stripper unit, slot, for ball-lock punch

d _s / (Order Code character)	W _{min}	G _{max}	a	b	e ₂	r ₁	r ₂	Punch type l (Order Code character)	SWL (D)	SWS (G)	SWL (E)	SWS (H)	SWL (F)	l ₁ S _(max)	37	40
															(A)	(B)
10 / (F)	1.6	9.9	44.5	43.7	26.925	9.5	12	l ₂	80	90	90	100	100	(Order Code character)	●	●
13 / (G)	4.5	12.9	50.8	50	29.97	12.7	15.2		●	●	●	●	●		●	●
16 / (H)	6	15.9	54	53.2	31.75	14.3	16.8		●	●	●	●	●		●	●
20 / (J)	8	19.9	60.3	59.5	33.53	17.5	20		●	●	●	●	●		●	●
25 / (K)	10	24.9	69.9	69.1	40.64	22.2	24.7		●	●	●	●	●		●	●
32 / (L)	12.5	31.9	69.9	69.1	40.64	22.2	24.7		●	●	●	●	●		●	●
38 / (M)	14	37.9	77.4	76	43.9	26	28.5		●	●	●	●	●		●	●
40 / (N)	14	39.9	77.4	76	43.9	26	28.5			●		●			●	●

d _s / (Order Code character)	Punch type Punch length l Scraper bush l ₁ Stripping force max. [N]	SWL	SWL	SWL	SWL	SWL	SWL	SWS	SWS	SWS	SWS
		080	080	090	090	100	100	090	090	100	100
10 / (F)		1022	884	1280	810	786	1098	1022	884	1280	810
13 / (G)		1022	884	1280	810	786	1098	1022	884	1280	810
16 / (H)		2856	1668	3128	1282	1920	2688	2856	1668	3128	1282
20 / (J)		5049	2714	5124	2180	3120	4368	5049	2714	5124	2180
25 / (K)		5049	2714	5124	2180	3120	4368	5049	2714	5124	2180
32 / (L)		5049	2714	5124	2180	3120	4368	5049	2714	5124	2180
38 / (M)		5049	2714	5124	2180	3120	4368				
40 / (N)								5049	2714	5124	2180

Ordering Code (example):

2667.FE4A.0800.0500.A

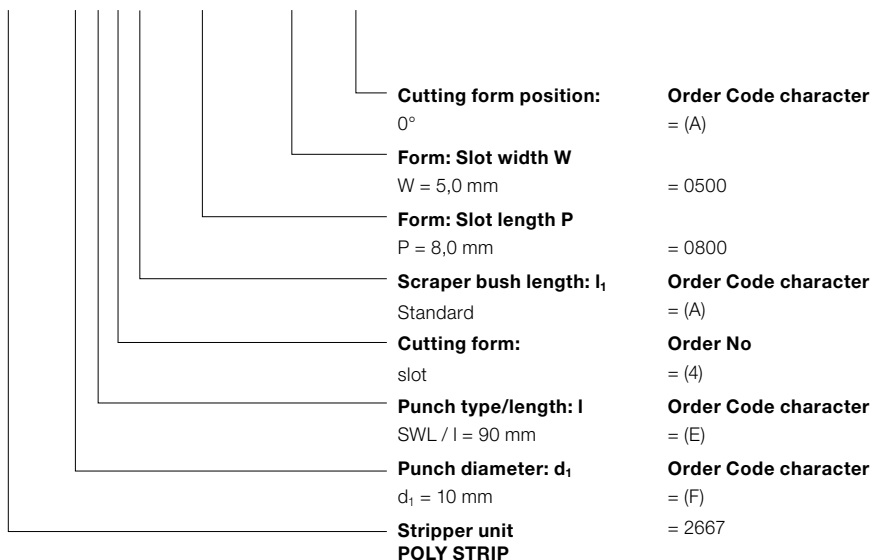

Description:

The brush cleaner unit is suitable for use with exterior skin panels. Use with triangular mounting plate, for ball-lock punch 2664.05./06./10.

Material:

Scraper bush: CuZn25Al5 (no. 2.0598)
Scraper plate: 40CrMnMoS8-6 (no. 1.2312)
Pressure plate: 40CrMnMoS8-6 (no. 1.2312)

Note:

The stripper unit is available in 2 variants: Standard (A) and Long (B). Long variant of the stripper unit with 3 mm projecting edge suitable for retrofitting a contour. Choose the position of the cutting form in the scraper bush in accordance with the position of the installed punch in the mounting plate.

POLY STRIP STRIPPER UNIT, SQUARE WITH RADIUS, FOR BALL-LOCK PUNCH

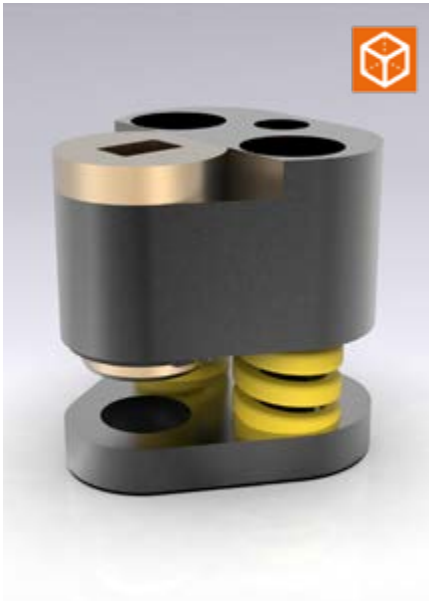

2667.□□5□.

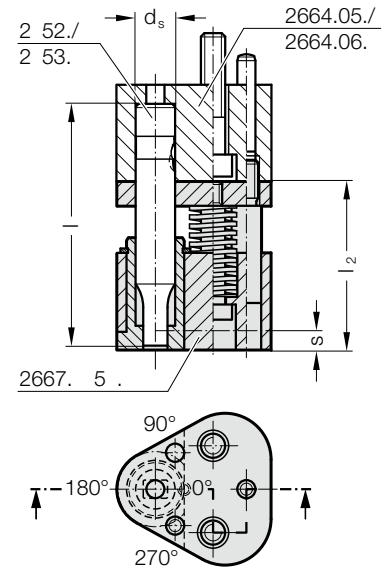
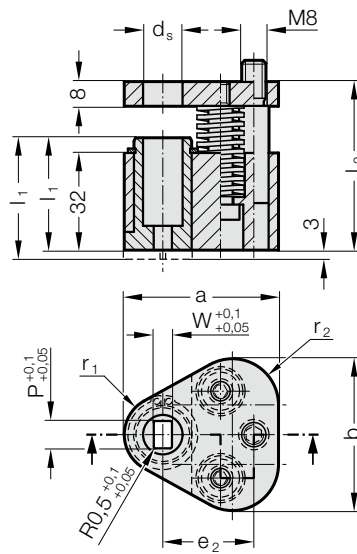

2667.xx5x. POLY STRIP stripper unit, square with radius, for ball-lock punch

d _s / (Order Code character)	W _{min}	G _{max}	a	b	e ₂	r ₁	r ₂	Punch type					l ₁ (Order Code character)	S _(max)	37 (A)	40 (B)
								l	SWL (D)	SWS (G)	SWL (E)	SWS (H)				
10 / (F)	1.6	9.9	44.5	43.7	26.925	9.5	12	80	90	90	100	100	37	6.5	9.5	
13 / (G)	4.5	12.9	50.8	50	29.97	12.7	15.2	●	●	●	●	●				●
16 / (H)	6	15.9	54	53.2	31.75	14.3	16.8	●	●	●	●	●				●
20 / (J)	8	19.9	60.3	59.5	33.53	17.5	20	●	●	●	●	●				●
25 / (K)	10	24.9	69.9	69.1	40.64	22.2	24.7	●	●	●	●	●				●
32 / (L)	12.5	31.9	69.9	69.1	40.64	22.2	24.7	●	●	●	●	●				●
38 / (M)	14	37.9	77.4	76	43.9	26	28.5	●	●	●	●	●				●
40 / (N)	14	39.9	77.4	76	43.9	26	28.5		●		●					●

d _s / (Order Code character)	Punch type	Punch length l	Scraper bush l ₁	Stripping force max. [N]	SWL	SWL	SWL	SWL	SWL	SWL	SWS	SWS	SWS	SWS
					080	080	090	090	100	100	090	090	100	100
10 / (F)			37	1022	884	1280	810	786	1098	1022	884	1280	810	
13 / (G)			40	1022	884	1280	810	786	1098	1022	884	1280	810	
16 / (H)			37	2856	1668	3128	1282	1920	2688	2856	1668	3128	1282	
20 / (J)			40	5049	2714	5124	2180	3120	4368	5049	2714	5124	2180	
25 / (K)			37	5049	2714	5124	2180	3120	4368	5049	2714	5124	2180	
32 / (L)			40	5049	2714	5124	2180	3120	4368	5049	2714	5124	2180	
38 / (M)			37	5049	2714	5124	2180	3120	4368					
40 / (N)			40							5049	2714	5124	2180	

Description:

The brush cleaner unit is suitable for use with exterior skin panels.
Use with triangular mounting plate, for ball-lock punch 2664.05./06./10.

Material:

Scraper bush: CuZn25Al5 (no. 2.0598)
Scraper plate: 40CrMnMoS8-6 (no. 1.2312)
Pressure plate: 40CrMnMoS8-6 (no. 1.2312)

Note:

The stripper unit is available in 2 variants: Standard (A) and Long (B).
Long variant of the stripper unit with 3 mm projecting edge suitable for retrofitting a contour.
Choose the position of the cutting form in the scraper bush in accordance with the position of the installed punch in the mounting plate.

Ordering Code (example):

2667.FE5A.0800.0500.A

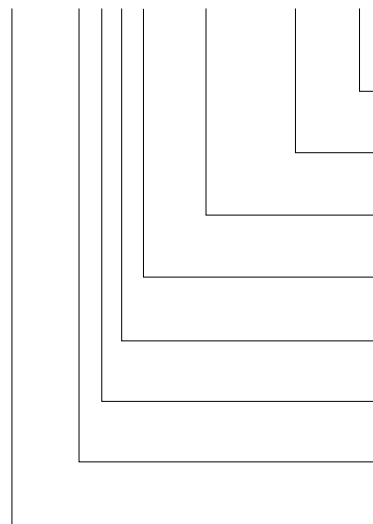

- Cutting form position:** Order Code character = (A)
- 0° = (A)
- Shape: rectangle with radiused corners Width W** = 0500
- W = 5,0 mm = 0500
- Shape: rectangle with radiused corners Length P** = 0800
- P = 8,0 mm = 0800
- Scraper bush length: l₁** Order Code character = (A)
- Standard = (A)
- Cutting form:** Order No = (5)
- rectangle with radiused corners = (5)
- Punch type/length: l** Order Code character = (E)
- SWL / l = 90 mm = (E)
- Punch diameter: d₁** Order Code character = (F)
- d₁ = 10 mm = (F)
- Stripper unit** = 2667
- POLY STRIP**

DOWEL PINS / LINER BUSHES FOR DOWEL PINS



DOWEL PIN SIMILAR TO DIN EN ISO 8734



235.1.

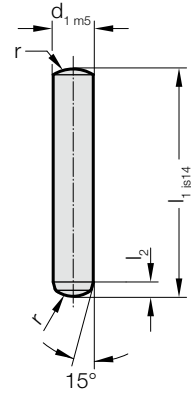

Material:

Steel
Hardness 60 ± 2 HRC

Execution:

hardened and ground to finest finish
FIBRO Dowel Pins are manufactured with the exacting requirements of high class diemaking in mind. Whereas DIN EN ISO 8734 stipulates ISO Class 6 for dowels, we produce our pins to m5.

235.1. Dowel pin similar to DIN EN ISO 8734

d ₁	l ₂	r	l ₁	6	8	10	12	14	16	18	20	24	28	32	36	40	45	50	55	60	70	80	90	100	120	130	140
1	0.48	1			●	●	●																				
1.5	0.62	1.6		●	●	●	●	●	●																		
2	0.78	2		●	●	●	●	●	●	●	●	●	●	●	●												
2.5	0.95	2.5		●	●	●	●	●	●	●	●	●	●	●	●	●											
3	1.1	3		●	●	●	●	●	●	●	●	●	●	●	●	●	●										
4	1.4	4		●	●	●	●	●	●	●	●	●	●	●	●	●	●	●	●	●							
5	1.7	5			●	●	●	●	●	●	●	●	●	●	●	●	●	●	●	●	●						
6	2.1	6				●	●	●	●	●	●	●	●	●	●	●	●	●	●	●	●	●	●	●	●	●	●
8	2.6	8					●	●	●	●	●	●	●	●	●	●	●	●	●	●	●	●	●	●	●	●	●
10	3	10							●	●	●	●	●	●	●	●	●	●	●	●	●	●	●	●	●	●	●
12	3.8	12									●	●	●	●	●	●	●	●	●	●	●	●	●	●	●	●	●
14	3.8	16													●	●	●	●	●	●	●	●	●	●	●	●	
16	4.7	16														●	●	●	●	●	●	●	●	●	●	●	
20	6	20															●	●	●	●	●	●	●	●	●	●	

Ordering Code (example):

Dowel pin similar to DIN EN ISO 8734	=	235.1.
Diameter d ₁	6 mm =	0600.
Length l ₁	10 mm =	010
Order No	=	235.1.0600. 010

DOWEL PIN ACCORDING TO DIN EN ISO 8734

2351.1.

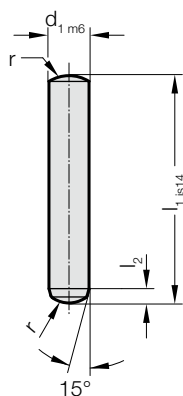

Material:

Steel
Hardness 60 ± 2 HRC

Execution:

hardened and ground to finest finish

2351.1. Dowel pin according to DIN EN ISO 8734

d ₁	l ₂	r	l ₁	4	5	6	8	10	12	14	16	18	20	22	24	26	28	30	32	36	40	45	50	55	60	70	80	90	100	120
1	0.4	1		•	•	•	•	•	•																					
1.5	0.5	1.6		•	•	•	•	•	•	•	•	•	•	•	•	•	•	•	•	•										
2	0.6	2		•	•	•	•	•	•	•	•	•	•	•	•	•	•	•	•	•	•									
2.5	0.7	2.5		•	•	•	•	•	•	•	•	•	•	•	•	•	•	•	•	•	•	•								
3	0.8	3		•	•	•	•	•	•	•	•	•	•	•	•	•	•	•	•	•	•	•	•							
4	1	4			•	•	•	•	•	•	•	•	•	•	•	•	•	•	•	•	•	•	•	•	•	•	•	•	•	•
5	1.2	5			•	•	•	•	•	•	•	•	•	•	•	•	•	•	•	•	•	•	•	•	•	•	•	•	•	•
6	1.5	6				•	•	•	•	•	•	•	•	•	•	•	•	•	•	•	•	•	•	•	•	•	•	•	•	•
8	1.8	8					•	•	•	•	•	•	•	•	•	•	•	•	•	•	•	•	•	•	•	•	•	•	•	•
10	2	10						•	•	•	•	•	•	•	•	•	•	•	•	•	•	•	•	•	•	•	•	•	•	•
12	2.5	12							•	•	•	•	•	•	•	•	•	•	•	•	•	•	•	•	•	•	•	•	•	•
14	2.5	16								•	•	•	•	•	•	•	•	•	•	•	•	•	•	•	•	•	•	•	•	•
16	3	16									•	•	•	•	•	•	•	•	•	•	•	•	•	•	•	•	•	•	•	•
20	4	20											•	•	•	•	•	•	•	•	•	•	•	•	•	•	•	•	•	•

Ordering Code (example):

Dowel pin according to DIN EN ISO 8734	=	2351.1.
Diameter d ₁	6 mm =	0600.
Length l ₁	8 mm =	008
Order No	=	2351.1. 0600. 008

DOWEL PIN WITH INTERNAL EXTRACTING THREAD, SIMILAR TO DIN EN ISO 8735



236.1.

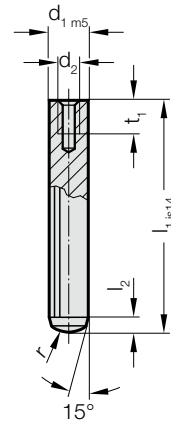

Material:

Steel
Hardness 60 ± 2 HRC

Execution:

hardened and ground to finest finish
FIBRO Dowel Pins are manufactured with the exacting requirements of high class diemaking in mind. Whereas DIN EN ISO 8735 stipulates ISO Class 6 for dowels, we produce our pins to m5.

236.1. Dowel pin with internal extracting thread, similar to DIN EN ISO 8735

d ₁	d ₂	t ₁	l ₂	r	l ₁	16	18	20	24	28	32	36	40	45	50	55	60	70	80	90	100	120
6	M4	6	2.1	6		•	•	•	•	•	•	•	•	•	•	•	•	•	•	•	•	•
8	M5	8	2.6	8				•	•	•	•	•	•	•	•	•	•	•	•	•	•	•
10	M6	10	3	10					•	•	•	•	•	•	•	•	•	•	•	•	•	•
12	M6	12	3.8	12						•	•	•	•	•	•	•	•	•	•	•	•	•
14	M8	12	4	16							•	•	•	•	•	•	•	•	•	•	•	•
16	M8	16	4.7	16							•	•	•	•	•	•	•	•	•	•	•	•
20	M10	20	6	20								•	•	•	•	•	•	•	•	•	•	•
25	M16	24	6	25									•	•	•	•	•	•	•	•	•	•

Ordering Code (example):

Dowel pin with internal extracting thread, similar to DIN EN ISO 8735	=	236.1.
Diameter d ₁	14 mm =	1400.
Length l ₁	32 mm =	032
Order No	=	236.1. 1400. 032

DOWEL PIN WITH INTERNAL EXTRACTING THREAD, ACCORDING TO DIN EN ISO 8735

2361.1.

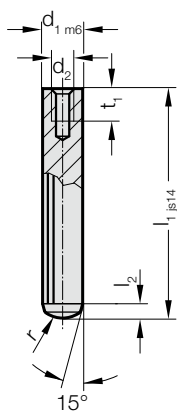

Material:

Steel
Hardness 60 ± 2 HRC

Execution:

hardened and ground to finest finish

2361.1. Dowel pin with internal extracting thread, according to DIN EN ISO 8735

d ₁	d ₂	t ₁	l ₂	r	l ₁	8	10	12	14	16	18	20	22	24	26	28	30	32	36	40	45	50	55	60	70	80	90	100	120
4	M2,5	4.5	1.3	4			•	•	•	•	•	•	•	•	•	•	•	•	•	•	•	•	•	•	•	•	•	•	•
5	M3	5	1.7	5		•	•	•	•	•	•	•	•	•	•	•	•	•	•	•	•	•	•	•	•	•	•	•	•
6	M4	6	2.1	6				•	•	•	•	•	•	•	•	•	•	•	•	•	•	•	•	•	•	•	•	•	•
8	M5	8	2.6	8					•	•	•	•	•	•	•	•	•	•	•	•	•	•	•	•	•	•	•	•	•
10	M6	10	3	10						•	•	•	•	•	•	•	•	•	•	•	•	•	•	•	•	•	•	•	•
12	M6	10	3.8	12							•	•	•	•	•	•	•	•	•	•	•	•	•	•	•	•	•	•	•
14	M8	12	4	14								•	•	•	•	•	•	•	•	•	•	•	•	•	•	•	•	•	•
16	M8	12	4.7	16									•	•	•	•	•	•	•	•	•	•	•	•	•	•	•	•	•
20	M10	16	6	20											•	•	•	•	•	•	•	•	•	•	•	•	•	•	•

Ordering Code (example):

Dowel pin with internal extracting thread, according to DIN EN ISO 8735	=	2361.1.
Diameter d ₁	10 mm =	1000.
Length l ₁	16 mm =	016
Order No	=	2361.1. 1000. 016

LINER BUSH FOR DOWEL PIN, FOR BONDING

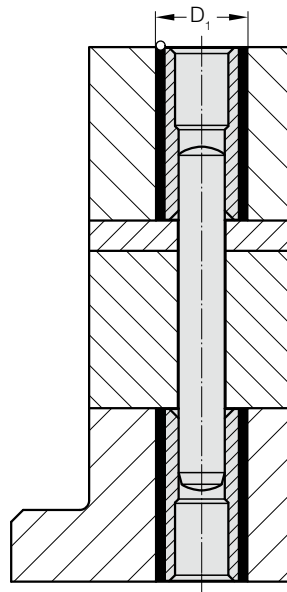

265.1.

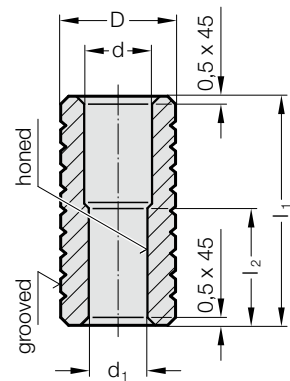

Description:

Dowel liner bushes are used where precisely positioned, unhardened parts are often changed or must be replaced, e.g. in precision tool construction.

Material:

WS
Hardness 54 ± 2 HRC

Epoxy-Bonding:

The jig-ground pin holes of the hardened matrix are joined with the dowel liner bush by means of a dowel pin 235.1. Retainer holes for dowel liner bushes should be approximately 2 mm larger in diameter than the bush O.D. – a coarse finish is desirable. Following exact positioning/aligning, FIBROLIT® ZWO or FIBROFIX® SECHS is used for bonding.

265.1. Liner bush for dowel pin, for bonding

d ₁	d	D	D ₁	l ₁	l ₂
6	7	10	12	25	12
8	9	12	14	30	16
10	11	16	18	36	20

Ordering Code (example):

1 Dowel Liner Bush – only –

Dowel Liner Bush	=	265.
Material WS	=	1.
d ₁ = ø 8,0 mm	=	0800.
Quantity – 1	=	1
Order No	=	265.1.0800.1

Ordering Code (example):

1 Dowel Liner Bush + 1 Dowel pin

Dowel Liner Bush	=	265.
Material WS	=	1.
d ₁ = ø 8,0 mm	=	0800.
Quantity – 1	=	1.
Dowel length = 40 mm	=	040
Order No	=	265.1.0800.1.040

Ordering Code (example):

2 Dowel Liner Bushes + 1 Dowel pin

Dowel Liner Bush	=	265.
Material WS	=	1.
d ₁ = ø 8,0 mm	=	0800.
Quantity – 2	=	5.
Dowel length = 50 mm	=	050
Order No	=	265.1.0800.2.050

LINER BUSH FOR DOWEL PIN, FOR PUSH FIT

2650.1.

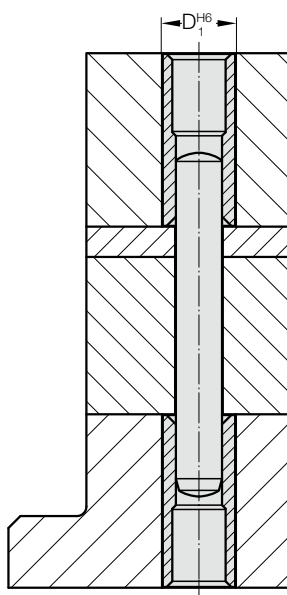
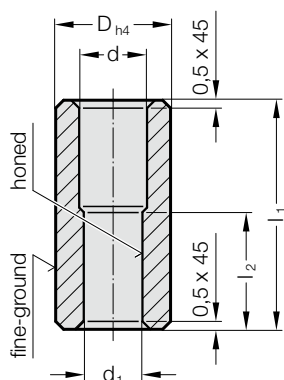

Description:

Dowel liner bushes are used where precisely positioned, unhardened parts are often changed or must be replaced, e.g. in precision tool construction.

Material:

WS
Hardness 54 ± 2 HRC

Slip-Fit Bonding:

The position of the bush is given by push fit hole tolerance H6. The adhesive (order no. 281.648) provides optimum push retention whilst offering the following **advantages:**

- high accuracy and stiffness
- no problems to find position when changing bushings

We do not recommend to press fit bushings.

2650.1. Liner bush for dowel pin, for push fit

d ₁	d	d ₂	l ₁	l ₂
6	7	10	25	12
8	9	12	30	16
10	11	16	36	20

Ordering Code (example):

1 Dowel Liner Bush – only –

Dowel Liner Bush	= 2650.
Material WS	= 1.
d ₁ = ø 8,0 mm	= 0800.
Quantity – 1	= 1
Order No	= 2650.1.0800.1

Ordering Code (example):

1 Dowel Liner Bush + 1 Dowel pin

Dowel Liner Bush	= 2650.
Material WS	= 1.
d ₁ = ø 8,0 mm	= 0800.
Quantity – 1	= 1.
Dowel length = 40 mm	= 040
Order No	= 2650.1.0800.1.040

Ordering Code (example):

2 Dowel Liner Bushes + 1 Dowel pin

Dowel Liner Bush	= 2650.
Material WS	= 1.
d ₁ = ø 8,0 mm	= 0800.
Quantity – 2	= 2.
Dowel length = 50 mm	= 050
Order No	= 2650.1.0800.2.050

FIBROZIPP



236.001 FIBROZIPP

For the extraction of cylinder and taper pins with female threads. Fast and convenient tool for toolmakers and fitters. The extraction tool is equipped with interchangeable adaptors and screws. Can be used to "zip" all standard female thread pins.

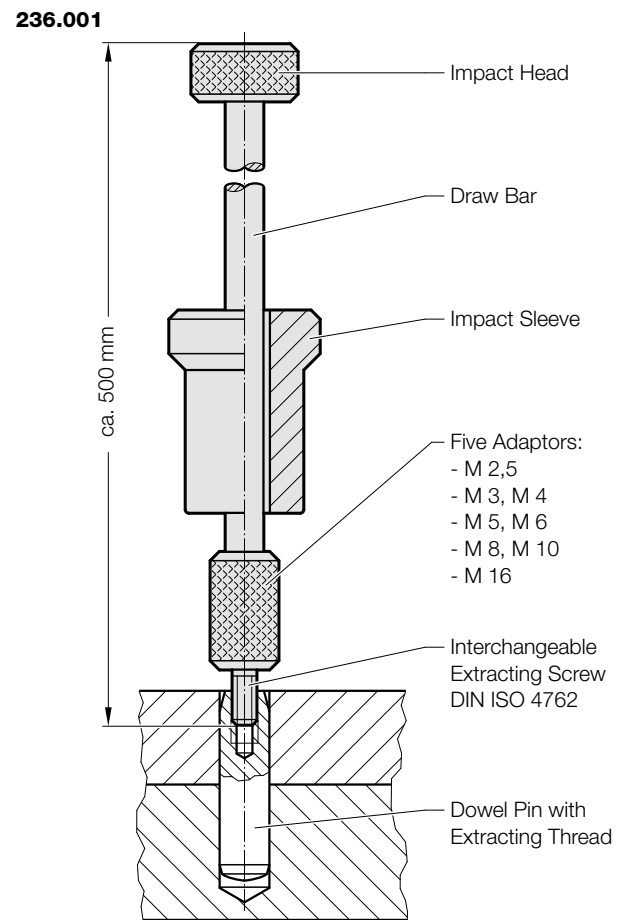

DRILL BUSHES DIN 172/179

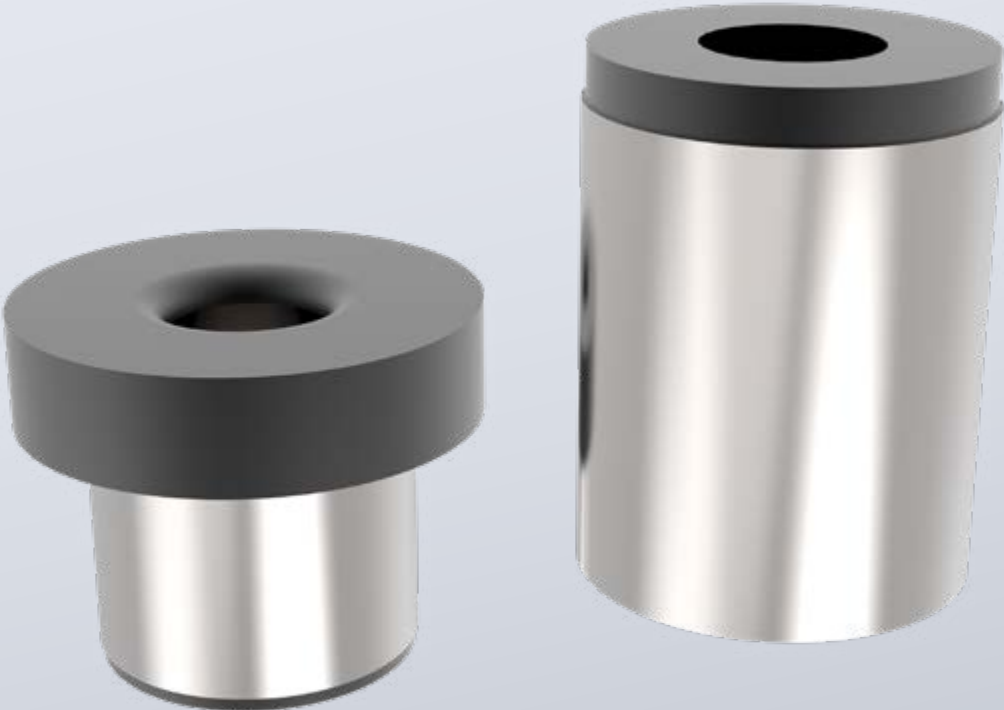

DRILL BUSH WITH COLLAR, DIN 172 SHAPE A



276.

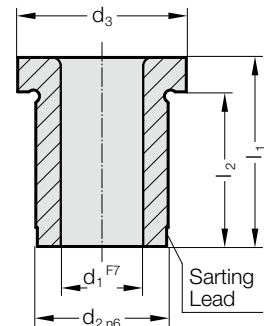

Material:

Case hardened steel
Hardness 740 ± 40 HV 10

Execution:

Diameters d_1 , d_2 and shoulder precision ground.

Other diameters and lengths on request.

276. Drill bush with collar, DIN 172 Shape A

d_1	d_2	d_3	Gradation	l_1	6	8	9	10	12	16	20	25	28	30	36	45	56	67
0,9 - 1	3	6	0.1	l_2	4		7											
1,1 - 1,8	4	7	0.1		4		7											
1,9 - 2,6	5	8	0.1		4		7											
2,7 - 3,3	6	9	0.1			5.5			9.5	13.5								
3,4 - 4	7	10	0.1			5.5			9.5	13.5								
4,1 - 5	8	11	0.1			5.5			9.5	13.5								
5,1 - 6	10	13	0.1				7			13	17							
6,1 - 8	12	15	0.1					7		13	17							
8,1 - 10	15	18	0.1						9		17	22						
10,1 - 12	18	22	0.1						8		16	21						
12,1 - 15	22	26	0.1							12			24		32			
15,5 - 18	26	30	0.5							12			24		32			
18,5 - 22	30	34	0.5								15				31	40		
22,5 - 26	35	39	0.5								15				31	40		
26,5 - 30	42	46	0.5									20				40	51	
30,5 - 35	48	52	0.5									20				40	51	
35,5 - 42	55	59	0.5											25			51	62

Ordering Code (example):

Drill bush with collar, DIN 172 Shape A = 276.1.

Diameter of conduit d_1 12.1 mm = 1210.

Length l_1 16 mm = 016

Order No = 276.1. 1210.016

DRILL BUSH WITHOUT COLLAR, DIN 179 SHAPE A

277.

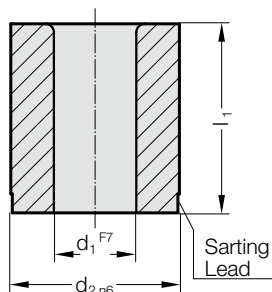

Material:

Case hardened steel
Hardness 740 ± 40 HV 10

Execution:

Diameters d_1 and d_2 precision ground.

Other diameters and lengths on request.

277. Drill bush without collar, DIN 179 Shape A

d_1	d_2	Gradation	l_1	6	8	9	10	12	16	20	25	28	30	36	45	56	67
0,9 - 1	3	0.1		●		●											
1,1 - 1,8	4	0.1		●		●											
1,9 - 2,6	5	0.1		●		●											
2,7 - 3,3	6	0.1			●			●	●								
3,4 - 4	7	0.1			●			●	●								
4,1 - 5	8	0.1			●			●	●								
5,1 - 6	10	0.1					●		●								
6,1 - 8	12	0.1					●		●	●							
8,1 - 10	15	0.1						●	●	●							
10,1 - 12	18	0.1						●	●	●	●						
12,1 - 15	22	0.1							●	●	●		●		●		
15,5 - 18	26	0.5							●			●		●			
18,5 - 22	30	0.5								●				●	●		
22,5 - 26	35	0.5								●				●	●		
26,5 - 30	42	0.5									●			●	●	●	
30,5 - 35	48	0.5									●			●	●	●	
35,5 - 42	55	0.5										●		●	●	●	●
42,5 - 48	62	0.5											●	●	●	●	●

Ordering Code (example):

Drill bush without collar, DIN 179 Shape A	=	277.1.
Diameter of conduit d_1	12.1 mm =	1210.
Length l_1	16 mm =	016
Order No	=	277.1. 1210.016

GAUGE PINS

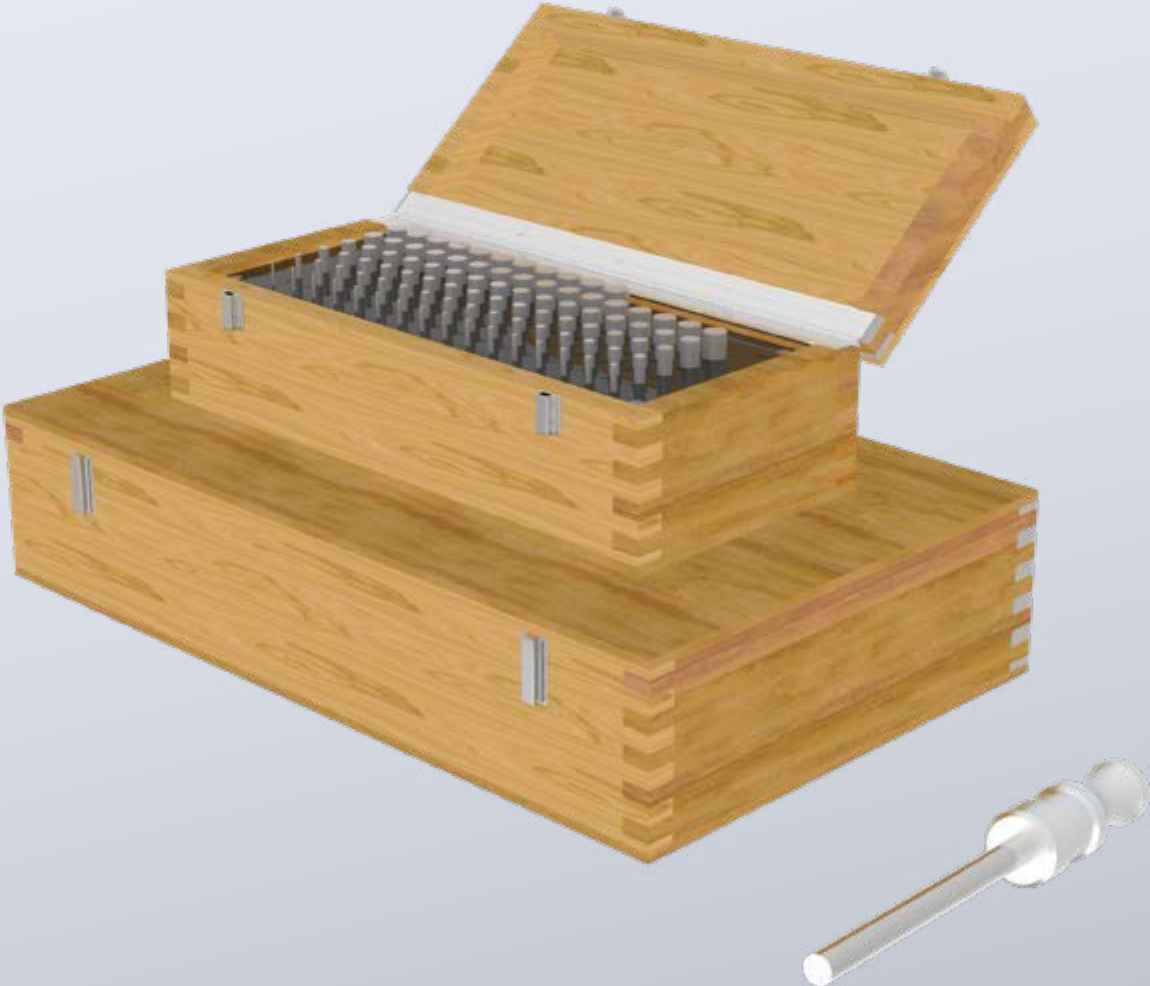

GAUGE PIN DIN 2269



240.1./2.

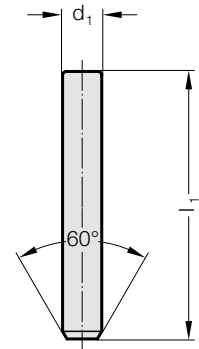

Material:

Alloy tool steel, hardened and tempered. Age-treated repeatedly.
Hardness 60 ± 2 HRC

Execution:

precision ground
Quality class I: diameter tolerance ±0,001
Quality class II: diameter tolerance ±0,002

Order example:

Quality class I = 240.1.
Quality class II = 240.2.

240.1./2. Gauge pin DIN 2269

d ₁	l ₁
0,1 - 0,99	40
1 - 20	70

Ordering Code (example):

Gauge pin DIN 2269	= 240.
Quality class KL 1	= 1.
Diameter d ₁ 1,29 mm	= 0129.
Length l ₁ 70 mm	= 070
Order No	= 240. 1. 0129. 070

EXAMPLE APPLICATIONS FOR CHECK PINS

Direct gauging of bore diameters

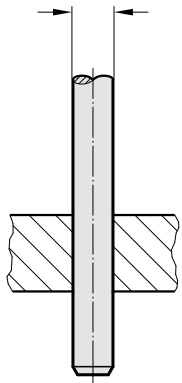

Measurement of centre-distance between two bores

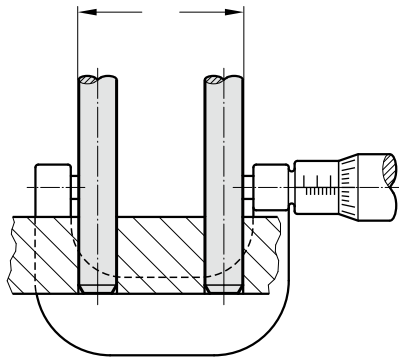

Concentricity check on a bush

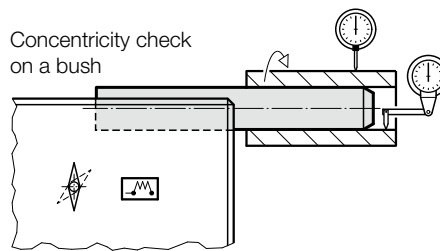

Measurements on prismatic faces

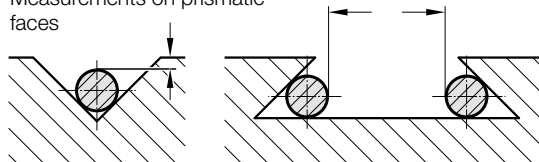

Calibration of a comparator

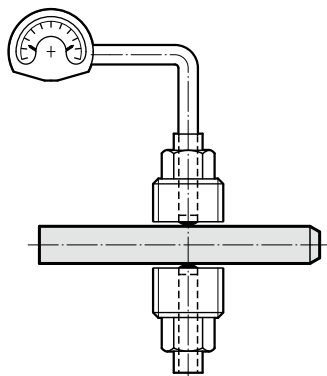

Inspection for squareness of a bore

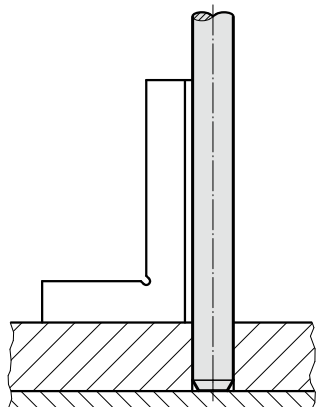

Check on parallelism

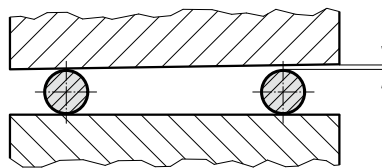

Measuring of gear teeth, threads etc.

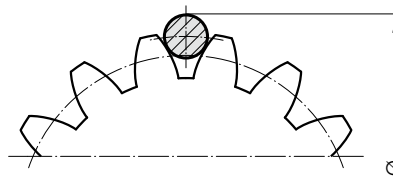

GAUGE PIN WITH HANDLE, DIN 2269



240.11./22.

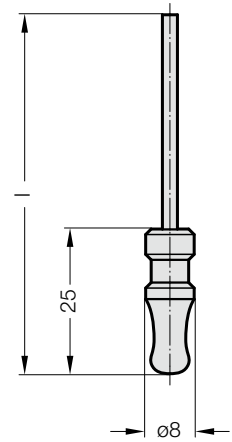

Material:

Alloy tool steel, hardened and repeatedly age-treated
Hardness 60 ± 2 HRC

Execution:

Extremely finely ground
Quality class I ± 0.001
Quality class II ± 0.002

The gauge pins are firmly fixed to the handle. Each pin is marked with its true diameter.

Order example:

Single gauge pins $\varnothing 0.5 - 3.0$ mm, increasing in diameter by 0.01
Quality class I = 240.11.
Quality class II = 240.22.

240.11./22. Gauge pin with handle, DIN 2269

d_1	l
0,5 - 0,99	58
1 - 3	88

Ordering Code (example):

Gauge pin with handle, DIN 2269 = 240.11.
Quality class I

$d_1 = 1,5$ mm = 0150

Order No = 240.11.0150

RANGE OF CHECK PINS IN STORAGE BOX

GAUGE PIN HOLDERS

WOODEN BOXES



240.51/52 Range of check pins in storage box small

Execution:

91 check pins, DIN 2269, from \varnothing 1-10 mm increasing by 0.1 mm, complete set in storage box with drilled inserts and measurement markings. From \varnothing 3 mm the check pins are marked with the measurements.

Order example:

Quality class I = 240.51
Quality class II = 240.52

240.41/42 Range of check pins in storage box large

Execution:

273 check pins, DIN 2269, from \varnothing 1-10 mm increasing by 0.1 mm. Each check pin size is each expanded once again with a -0.01 mm undersize and a +0.01 mm oversize, complete set in storage box with drilled inserts and measurement markings.

From \varnothing 3 mm the check pins are marked with the measurements.

Order example:

Quality class I = 240.41
Quality class II = 240.42

Note:

Custom ranges available in quality classes I and II according to your specifications.

From \varnothing 3 mm the check pins are marked with the measurements.



240.45. Gauge Pin Holders

Execution:

Gauge pin holders are double-ended, to carry two pins (e.g. for go – no go measurements, without gauge pins)

Order example:

for diameters
of 1 – 2 = 240.45.1
of 2 – 4 = 240.45.2
of 4 – 6 = 240.45.3
of 6 – 8 = 240.45.4
of 8 –10 = 240.45.5



240.91/92 Wooden boxes, no content

Execution:

Wooden storage boxes for protected and tidy storage of check pins. Without check pins. Without drilled insert and measurement markings.

Order example:

For large set of approx. 270 items with approx. external dimensions
250×90×390 = 240.91
For small set of approx. 90 items with approx. external dimensions
155×90×285 = 240.92

SPECIAL PUNCHES AND MATRIXES TO CUSTOMER'S DRAWINGS



FIBRO manufactures special form punches and -matrices on most modern equipment. Projection form grinding, creep feed grinding, EDM and Wire-EDM are used to design details. Many

years of experience enable FIBRO to choose best suitable materials and methods. We manufacture to customer's drawings: Piercing punches, draw punches, form punches, pre-extrusion punches

and ejectors for bolt manufacturing, flow-forming punches, punches with 30°-conical heads or other head shapes



